

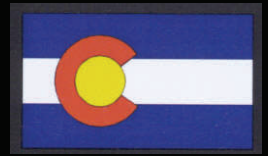

Guideline for the Design and Use of Asphalt Pavements for Colorado Roadways



PREFACE

This document has been developed so as to aid in the proper design, construction, and maintenance of asphalt pavements in Colorado. It is not intended to replace any standards or requirements that may be established.

We would like to thank each of the representatives that reviewed a draft copy of the report and had input into its final product. Like any document of this nature, changes, updates, and corrections will be needed. We envision an updated version made every two to three years. Please let us know of any discrepancies that you come across or insights that you have to strengthen the document in the next edition.

The document was originally developed based on one produced by the Missouri Asphalt Pavement Association. Western Colorado Testing, Inc. of Grand Junction was retained by CAPA to coordinate its development. We thank both of these organizations.

The second edition is based on the information contained in the first edition with update and additional information from other Colorado Asphalt Pavement Association documents.

Through the development and use of this guide, we can further our mission of developing, improving, and advancing the quality of asphalt pavements in Colorado. Hopefully, you will find it to be an effective resource.

To obtain additional copies, please contact;

Colorado Asphalt Pavement Association
6880 South Yosemite Court, Suite 110
Centennial, Colorado 80112
303-741-6150
E-mail: office@co-asphalt.com
Website: www.co-asphalt.com

ENDORSEMENTS

This guideline was developed in cooperation with a number of organizations and associations. The following have endorsed this Guideline as a reference for the design and use of HMA pavements in Colorado:



ASPHALT INSTITUTE



**COLORADO ASSOCIATION OF
ROAD SUPERVISORS AND ENGINEERS**

The following organizations reviewed the original document:

**COLORADO CHAPTER OF THE AMERICAN
PUBLIC WORKS ASSOCIATION**



**METROPOLITAN GOVERNMENT
PAVEMENT ENGINEERS COUNCIL**



**A GUIDELINE FOR THE DESIGN AND USE OF
ASPHALT PAVEMENTS FOR COLORADO ROADWAYS**

TABLE OF CONTENTS

PREFACE

ENDORSEMENTS

TABLE OF CONTENTS

CHAPTER ONE ASPHALT AND HOT MIX ASPHALT PAVING MATERIALS

CHAPTER TWO PAVEMENT DESIGN CONSIDERATIONS

CHAPTER THREE THICKNESS DESIGN

CHAPTER FOUR SUBGRADE AND AGGREGATE BASE COURSE STABILIZATION

CHAPTER FIVE CONSTRUCTION OF HOT MIX ASPHALT PAVEMENTS

CHAPTER SIX GEOSYNTHETICS AND THEIR APPLICATION

CHAPTER SEVEN HIGH TRAFFIC VOLUME INTERSECTION DESIGN

CHAPTER EIGHT PARKING LOT DESIGN

CHAPTER NINE DESIGN FOR RECREATIONAL USES

CHAPTER TEN LIFE CYCLE COST ANALYSIS

CHAPTER ELEVEN PAVEMENT MANAGEMENT

CHAPTER TWELVE PAVEMENT REHABILITATION AND RUBBLIZATION

CHAPTER THIRTEEN PAVEMENT MANAGEMENT FOR AIRPORT

CHAPTER FOURTEEN TROUBLESHOOTING AND IDENTIFICATION OF PAVEMENT FAILURES

APPENDICES

APPENDIX A ASPHALT BINDER GRADE SELECTION

APPENDIX B MGPEC Form #9

APPENDIX C WEB SITE ADDRESS

CHAPTER ONE

ASPHALT AND HOT MIX ASPHALT PAVING MATERIALS

CHAPTER ONE

ASPHALT AND HOT MIX ASPHALT PAVING MATERIALS

HOT MIX ASPHALT PAVEMENT

Hot Mix Asphalt pavement is known by many different names: asphalt concrete, plant mix, bituminous mix, bituminous concrete, and many others. With the implementation of Superpave across the United States, there has been a trend to standardize the terminology and use Hot Mix Asphalt. The terminology that will be used for asphalt pavement throughout this guideline will be **Hot Mix Asphalt (HMA)**.

Hot Mix Asphalt is a combination of two primary ingredients - aggregates and an asphalt binder. The aggregates total ninety to ninety five percent of the total mixture by weight. They are mixed with approximately four to eight percent asphalt binder to form HMA.

The aggregates and asphalt are combined in an efficient manufacturing plant capable of producing Hot Mix Asphalt paving materials. Plant equipment includes: cold feed bins for storage of graded aggregate; a dryer for drying and heating aggregates to the required mixing temperature; a pug mill for combining the graded and heated aggregate with a liquid asphalt cement according to specified mix formulas; and tanks for storing the liquid asphalt binder. CDOT requires one percent hydrated lime to be added to mixes to help insure the coating of the aggregate by the asphalt binder.

HMA is transported by truck to the paving site where it is spread to a uniform thickness with a mechanical paving or finishing machine. After being placed to the desired thickness as specified for each individual lift, the HMA is compacted to the required density by heavy, self-propelled rollers, producing a smooth, well-compacted pavement course.

The paving or finishing machine places the HMA at temperatures above 285° F. Generally, the material is compacted before the mix temperature falls below 180° F to achieve required density.

There are approximately 12 million tons of HMA placed in Colorado each year. A majority of this amount is placed on city, county, commercial and residential type projects.

ASPHALT BINDER DEFINED

The black cementing agent known as asphalt binder has been used in road construction for centuries. Although there are natural deposits of asphalt, or rock asphalt, most of the asphalt used today is produced by the oil refining industry. Asphalt, a constituent of most petroleum products, is isolated through the refining process of distillation. The distillation process for obtaining asphalt from heavy crude oil is shown in **Figure 1-1**.

Asphalt is called a bituminous material because it contains bitumen, a hydrocarbon material soluble in carbon disulfide. The tar obtained from the destructive distillation of soft coal also contains bitumen. Both petroleum asphalt and coal tar are referred to as bituminous materials. However, because their properties differ greatly, petroleum asphalt should not be confused with coal tar. Petroleum asphalt is composed

almost entirely of bitumen. The bitumen content in coal tar is relatively low. Therefore, the two materials should be treated as separate entities.

One of the characteristics and advantages of asphalt as an engineering construction and maintenance material is its great versatility. Although a semi-solid at ordinary atmospheric temperatures, asphalt can be liquefied by applying heat, dissolving it in solvents, or emulsifying it. Asphalt is a strong type of cement that is readily adhesive, highly waterproof and durable, making it particularly useful in road building. It is also highly resistive to the actions of most acids, alkalis, and salts.

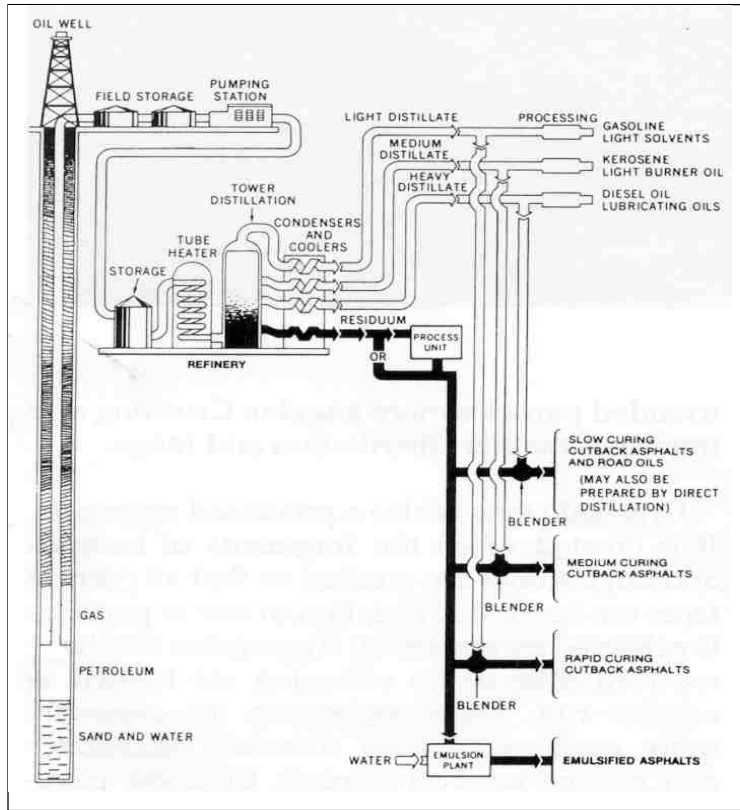

ASPHALT BINDER

Asphalt binder is produced in a variety of types and grades ranging from hard-brittle solids to near water-thin liquids. The semi-solid form, referred to as Asphalt Cement (AC) has been the basic material used in HMA pavements. Asphalt binder is a neat, un-modified asphalt. Asphalt binders that are modified to enhance performance, under the Superpave system are termed **modified asphalt binders**. An asphalt binder may or may not be modified. The terminology, "Asphalt Binder", is being standardized by the Superpave system. Superpave asphalt binders are discussed later in this chapter.

Some of the types and characteristics and the uses of asphalt binder are noted in Table 1-1.



LIQUID ASPHALT

Cutback Asphalt

Cutback asphalts are liquid asphalts which are manufactured by adding (cutting back) petroleum solvents (also called cutter stock or diluents) to asphalt cements. They are made to reduce the asphalt viscosity for lower application temperatures. Application to aggregate or pavement causes the solvent to escape by evaporation, thus leaving the asphalt cement residue on the surface. Based on the relative rate of evaporation, cutback asphalts are classified into three types: **Rapid Cure (RC)**, **Medium Cure (MC)** and **Slow Cure (SC)**.

The type of distillate (solvent) used in their production determines the grade of the cutback asphalt. Rapid Cure grades are typically blended with light, highly volatile diluents, such as naphtha, that will evaporate quickly and leave a hard, viscous-base asphalt to function with the aggregate on the road. Medium Cure grades are “cutback” with a less volatile kerosene-type of solvent which evaporates more slowly leaving a base asphalt of medium hardness or viscosity. Slow-Curing blends contain a low-volatility fuel-oil type solvent and thus require the longest curing period. They leave a soft, low-viscosity asphalt on the aggregate. Slow Cure grades are not used as much as the Rapid Cure and Medium Cure grades as it typically takes many months for these heavy diluents to evaporate and cure. The various sub-grades within a grade of cutback asphalts are determined by the amount of solvent used in their production.

Some of the types and characteristics of cutback asphalts are also noted in Table 1-1. The table also lists some of the available grades of cutbacks.

The use of cutback asphalt and its availability has been greatly reduced due to environmental restrictions (solvents evaporating into the atmosphere, causing air pollution).

Emulsified Asphalt

An asphalt emulsion is produced by combining asphalt cement, water and an emulsifying agent through a high-shear device called a colloid mill. Hot AC is pumped into the colloid mill where it is sheared into very small droplets, typically within the range of one to ten microns in diameter. Simultaneously, an emulsifying agent, dispersed in water, is pumped into the colloid mill. The emulsifying agent is both hydrophilic (likes water) and lipophilic (likes oil/asphalt). The lipophilic part attaches itself to the asphalt particle and the hydrophilic side suspends these particles in the water medium. From the colloid mill, the asphalt emulsion is then directed to its respective storage tank. The asphalt cement makes up from 55 to 70 percent of the emulsion. Most emulsions are made with asphalt in the 100-250 penetration range.

As usage and grade dictate, asphalt emulsions may contain additional stabilizers, coating enhancers, anti-stripping agents, solvents and break control agents that can be either co-milled during production or post-added into the emulsion.

There are three categories of emulsified asphalt, **Anionic**, **Cationic** and **Nonionic**. The emulsifying agents impart minute electrical charges on the emulsion droplets. If the droplet charge is negative, the emulsion is Anionic. A positively charged emulsion is a Cationic emulsion. Nonionic emulsions are neutral, and their droplets have no electrical charge. Most asphalt emulsions used in the paving industry are either Anionic or Cationic. Nonionic emulsions are seldom used.

Emulsions are graded based on how quickly the asphalt droplets coalesce, that is, recombine into asphalt cement. **Rapid Setting (RS)** grades of emulsion tend to coalesce very quickly after coming in contact with aggregate and hence have little or no ability to mix with aggregate. RS grades are typically used for chip and/or sand seals. **Medium Setting (MS)** grades are expected to mix with coarse aggregates but not fine aggregates. **Slow Setting (SS)** and **Quick Setting (QS)** emulsions are formulated to mix with fine aggregates. A Quick Setting emulsion will break (start coalescing) sooner than a Slow Setting emulsion. The QS grades are typically used for Slurry Seal. Some of the types and characteristics of emulsified asphalts are also noted in Table 1-1.

Table 1-1
Asphalt Types, Characteristics and General Uses¹

Type/Grade	Percent Min.	Asphalt Type - Percent Cutback	Penetration (Min-Max)	Flash (Min)	Point ²	Application Temperature ° F	General Uses
AC-2.5	100	0	220	325°F		260-330	Recycled Asphalt Pavement (RAP)
AC-5	100	0	120-270	350°F		260-330	ATB, Type B Base, RAP
AC-10	100	0	80-140	425°F		260-330	General Plant Mix, Surface Course, RAP
AC-20	100	0	60-120	450°F		260-330	Interstate/High Vol. Road Surf. Course
AC-40	100	0	40-70	450°F		260-330	Interstate/High Vol. Road Surf. Course
PAC-2.5	100	0	220	325°F		260-330	Recycled Asphalt Pavement (RAP)
PAC-5	100	0	140	350°F		260-330	ATB, Type B Base, RAP
SS-1	57	Water 43	100-200	*		70-160	Tack
SS-1h	57	Water 43	40-90	*		70-160	Tack, Slurry Surface Treatment
CSS-1	57	Water 43	100-250	*		70-160	Tack
CSS-1h	57	Water 43	40-90	*		70-160	Tack, Slurry Surface Treatment
CRS-1	60	Water 40	100-250	*		125-170	Bituminous Seal Coat
CRS-2	65	Water 35	100-250	*		125-170	Bituminous Seal Coat
			Viscosity				
RC-70	55	Naptha 45	70-140	80°F			Tack
MC-70	55	Kerosene 45	70-140	100°F		145-165	Bit. Seal Coat, Tack, Cold Mix, Patch Mix
MC-250	67	Kerosene 33	250-500	150°F		165-200	Bit. Seal Coat, Tack, Cold Mix, Patch Mix
MC-800	75	Kerosene 25	800-1600	150°F		175-255	Bit. Seal Coat, Tack, Cold Mix, Patch Mix
MC-3000	80	Kerosene 20	3000-6000	150°F		215-290	Bituminous Seal Coat

¹ AASHTO M-226, Table 2 see Specification 4137

²Note: Flash-point does not necessarily indicate burning or explosive point. However, care should be exercised when heating RC and MC asphalts because the cutback used reacts the same as gasoline. Material used as cold patch should be mixed at the lowest temperature possible to prevent loss of cutback causing the mixture to harden before use.

*Boils Over at 180°F.

Further, the numbers "-1" (for lower viscosity - thinner) and "-2" (for higher viscosity - thicker) designates the viscosity of an emulsion. A small "h" or "s" is used to designate that harder or softer based asphalt was used in its production. If the emulsion is manufactured with polymer-modified asphalt then its designation will contain a "p". The "HF" preceding some of the Anionic grades indicates High-Float, as measured by the viscosity float test. High-float emulsions have a quality that permits a thicker asphalt film on the aggregate particles with minimum probability of drainage.

Examples of emulsion designation are as follows:

- **CMS-2s** is a Cationic, Medium Setting grade of emulsion with a high viscosity, made from soft asphalt cement.
- **CSS-1h** is a Cationic, Slow Setting emulsion with a low viscosity made from hard asphalt.
- **CRS-2p** is a Cationic Rapid Setting emulsion with a high viscosity, manufactured from polymer-modified asphalt.

When there is an absence of the letter C, an anionic emulsion is designated.

- **HFMS-2s** is an Anionic, High-Float, Medium Setting grade of emulsion with a high viscosity and made with soft asphalt cement.
- **SS-1h** is an Anionic, Slow Setting, low viscosity asphalt emulsion made with hard asphalt.
- **HFRS-2p** is an Anionic, High-Float Rapid Setting grade of high viscosity manufactured from polymer-modified asphalt.

The designations, RS, MS, SS and the viscosity designations "-1" and "-2" are relative only to each other.

Because emulsified asphalt contains water, certain precautions must be observed when storing them:

- Store as you would fluid water, between 50°F (10°C) and 185°F (85°C), depending on use and grade.
- Use hot water as the heating medium for storage tanks with heating coils.
- Store at the temperature specified for the particular grade.
- Do not heat emulsified asphalt above 185°F (85°C)
- Do not let emulsified asphalt freeze.
- Do not let the heating surface exceed 212°F. (100°C) for it will break the emulsion on the heating surface.
- Do not mix different categories, types and grades of emulsified asphalt.

Emulsified asphalt is a versatile and environmentally friendly product that has been used successfully in Colorado since 1960. A list of general uses of emulsified asphalt is shown in Table 1-2. For more information on the use of emulsified asphalt, consult **MS-19, "A Basic Asphalt Emulsion Manual"**, a

publication of The Asphalt Institute. This manual is also available on-line at www.asphaltinstitute.org. Also consult your local emulsion supplier for more specific information.

Table 1-2
General Uses of Emulsified Asphalt in Colorado

Type of Construction	ASTM D 2397 AASHTO M 140						ASTM D 2397 AASHTO M 140					
	MS-1 HFMS -1	MS -1 HFMS -2	MS -1 HFMS -2h	HFMS -2h	SS -1	SS -1h	CRS -1	CRS -2	CMS -2	CMS -2h	CSS -1	CSS -1h
<u>Asphalt – aggregate mixtures</u> For pavement bases and surfaces: Plant mix (hot) Plant mix (cold) Open graded aggregate Dense-graded aggregate Sand		X	X ^A X	X X	X X	X X			X	X	X	X
<u>Mix-in-place</u> Open-graded aggregate Dense-graded aggregate Sand Sandy soil Slurry seal		X	X	X X X X	X X X X	X X X X			X	X	X X X X	X X X X
<u>Asphalt-aggregate applications:</u> Treatments and seals: Single surface treatment (Chip seal) Multiple surface treatment Sand seal							X X X	X X X				
<u>Asphalt applications:</u> Fog seals Prime coat-penetrable surface Tack coat Dust binder Mulch treatment Crack filler	X X ^B X ^B		X ^D		X ^C X ^D X ^C X ^C X	X ^C X ^D X ^C X ^C X					X ^C X ^D X ^C X ^C X	X ^C X ^D X ^C X ^C X
<u>Maintenance mix:</u> Immediate use				X	X	X					X	X
A- Grade of emulsion other than HFMS – 2h may be used where experience has shown that they give satisfactory performance B- May be diluted with water by the manufacturer C- Diluted with water D- Mixed – in prime only												

SUPERPAVE ASPHALT BINDERS

As a result of the Strategic Highway Research Program (SHRP), a new system for specifying asphalt materials was developed. The unique feature of the system regarding asphalt binders is it is a performance-based specification. The SHRP asphalt research program resulted in a new system known as *Superpave* (**Superior Performing Asphalt Pavements**). Superpave now represents an improved system for specifying asphalt binders and mineral aggregates, developing asphalt mixture design, and analyzing and establishing pavement performance that have a direct relationship to field performance. Asphalt binders are now being classified based on their performance at both hot and cold temperatures and are referred to as **Performance Graded (PG) binders**. Whereas, the old method of specifying asphalt cements was by viscosity and penetration.

A short coming of the old methods of grading asphalt is that under the penetration and viscosity grading systems, two asphalts may have the same properties at the tested temperature and be much different at another temperature. This variation is illustrated in Figure 1-2.

The intent behind the new Superpave system asphalt binder specification was to enhance an asphalt pavement's ability to prevent low temperature thermal cracking at the cold temperatures and to prevent permanent deformation or rutting at the high temperatures.

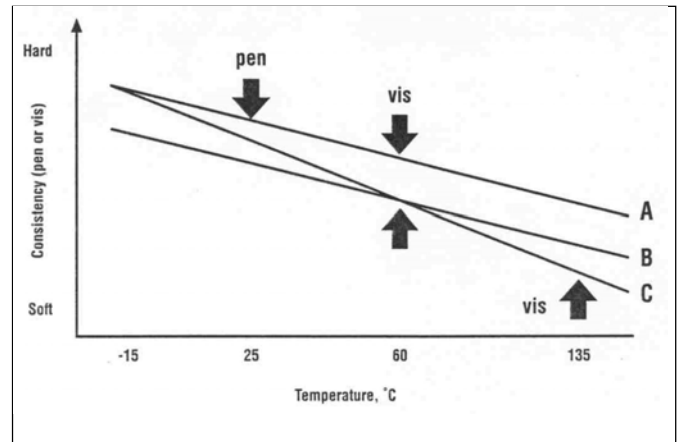

Performance Graded (PG) binders have two numbers in their designation such as PG 58-34. Both numbers describe the pavement temperatures in Celsius degrees at which the pavement must perform. The first number (58 [136° F] in the example) is the high temperature standard grade for the pavement, and the second number (Minus 34 [29° F] in the example) is the low temperature standard grade. This pavement service temperature range (58° C to minus 34° C) is the range the pavement is expected to perform. The high pavement temperature is measured 20 mm below the pavement surface while the low temperature is that of the pavement surface.

A comparison of viscosity graded binders to approximate PG graded binders is shown in Table 1-3. For severe temperature variation it is necessary to modify the PG graded binders. Typical modifiers are polymers and latex. For example, a soft base AC binder is used for the cold properties of the binders and a modifier is added to control the hot properties of the binder's performance. A general rule of thumb is that if the sum of the two numbers in the designation of the binder is greater than 90 (know as the rule of 90's), the asphalt binder is more likely to be a modified binder. For example, PG 58-22, the sum of the two numbers is 80, therefore, PG 58-22 is a non-modified asphalt binder. A PG 76-28, the sum of the two numbers is 104, therefore, PG 76-28 is a modified asphalt binder. The cost of the asphalt binder increases as the extent of the modification increases.

Table 1-3
Comparison of Viscosity Graded Binder to Approximate PG Graded Binders¹

Non - Modified Binders		Modified Binders	
Viscosity Graded	PG Graded	Viscosity Graded	PG Graded
AC- 5	PG 58-28		PG 58-34
AC - 10	PG 58-22	AC - 20 R	PG 64-28
AC - 20	PG 64-22		PG 70-28
		AC - 20 P	PG 76-28

¹ Depending on binder supplier -
Chart is used as an approximate comparison of viscosity grades to PG grades

Most geographic regions in Colorado utilize two primary PG grades of asphalt binder. Typically, one non-modified grade and one modified grade. For example, CDOT Region 4 typically uses a PG 58-22 and a PG 64-28. Table 1-4 lists the PG graded binders that are utilized in each CDOT region.

Table 1-4
PG Grades of Binders Specified by CDOT for Different Geographic Areas in Colorado

Region	PG Grades
Region 1 (Eastern Plains)	76-28, 64-22, 64-28*, 58-28
Region 2 (Pueblo)	76-28, 64-22, 64-28*, 58-28
Region 3 (Grand Junction)	76-28*, 64-28*, 58-28, 58-34
Region 4 (Greeley)	76-28*, 64-22, 64-28*
Region 5 (Durango)	76-28, 64-22, 58-28, 58-34*
Region 6 (Metro Denver)	76-28*, 64-22

* Denotes grades that are most likely modified.

Table 1-4 list the PG Grade Binder specifications for binders used in Colorado.

Appendix A provides a theoretical guide for the selection of Superpave binders and the Superpave mix design process. Also contained in Appendix A is CDOT's procedure for selecting Superpave binders. The most helpful resource to local agencies for determining the best binder for their locale is CDOT's Regional Materials Engineers or asphalt suppliers. They are knowledgeable regarding which PG graded binders work best with the aggregates and temperatures in their regions.

Table 1-5
Performance Graded Asphalt Binder Specifications

Performance Grade	PG 58			PG 64		PG 76
Average 7-day Pavement Design Temperature, °C	-22	-28	-34	-22	-28	- 28
Minimum Pavement Design Temperature, °C	<58			<64		<76
Original Binder						
Flash Point Temp, T 48, Minimum °C	230					
Viscosity, ASTM D 4402: Maximum, 3 Pa-s (3000 cP), Test Temp @ 10 rad/sec, °C	135					
Dynamic Shear, TP5: G*/sin δ, Minimum, 1.00 kPa Test temp @ 10 rad/sec, °C	58		64		76	
Rolling Thin Film Oven (T 240) or Thin Film Oven (T 179) Residue						
Maximum Loss, Maximum, %	1.00					
Dynamic Shear, TP5: G*/sin δ, Minimum, 2.20 kPa Test temp @ 10 rad/sec, °C	58		64		76	
Pressure Aging Vessel Residue (PPI)						
PAV Aging temperature, °C	100			100		100 (110)
Dynamic Shear, TP5: G*/sin δ, Minimum, 5000 kPa Test temp @ 10 rad/sec, °C	22	19	18	25	22	28
Physical Hardening						
Report						
Creep Stiffness, TP1: S, Maximum, 300 MPa m-value, Minimum, 0.300 Test Temp, @ 60 Sec, °C	-12	-18	-24	-12	-18	-18
Direct Tension, TP3: Failure Strain, Minimum, 1.0% Test Temp @ 1.0 mm/min, °C	-12	-18	-24	-12	-18	-18

AGGREGATES

Aggregates (or mineral aggregates) are hard, inert materials such as sand, gravel, crushed stone, slag, or rock dust. Properly selected and graded, aggregates are mixed with the cementing medium asphalt to form pavements. Aggregates are the principal load-supporting components of HMA pavement. Typically they total ninety to ninety five percent of the mixture by weight and 75 to 85 percent by volume.

The rich supply of natural resources in the Rocky Mountains provides the majority of Colorado with high quality paving materials. In Colorado, aggregates come from river deposits, talus gravel, either from river or glacial deposits, and quarried bedrock deposits. The aggregates that are produced in Colorado are very highly resistant to abrasion and low in permeability, which is essential to quality asphalt pavements. Geologically, the aggregates are mostly granites, limestone, andesite, and basalt.

AGGREGATE CLASSIFICATIONS

HMA paving aggregates are classified according to source or means of preparation. A brief description of the classifications follows:

Pit or Bank-Run Aggregates. Both gravel and sand are typically pit or bank-run natural aggregates. They usually are screened to proper size and washed to remove dirt before being used for HMA paving purposes.

Processed Aggregates. When natural pit or bank-run aggregate has been crushed and screened to make it suitable for HMA pavements, it is considered a processed aggregate. Crushing typically improves the particle shape by making the rounded particles more angular. Crushing also improves the size distribution and range.



Crushed stone is also a processed aggregate. It is created when the fragments of bedrock and large stones are crushed so that the particle faces are fractured. Variation in size of particles is achieved by screening. Aggregates that have received little or no screening are known as crusher run. These aggregates are generally more economical than screened aggregates and can be used in HMA pavements in some instances.

Synthetic Aggregates. Aggregates produced by altering both physical and chemical properties of a parent material are called synthetic or artificial aggregates. Some are produced and processed specifically for use as aggregates; others are the byproduct of manufacturing and a final burning process. Blast furnace slag is an example of a synthetic aggregate. The Pueblo steel mill is a local source of blast furnace slag.



DESIRABLE PROPERTIES OF AGGREGATES

Selection of an aggregate material for use in an HMA pavement depends on the availability, cost and quality of the material, as well as the type of construction for which it is intended. To determine if an aggregate material is suitable for use in asphalt construction, it should be evaluated in terms of the following properties:

1. **Size and grading** - The maximum size of an aggregate is the smallest sieve through which 100 percent of the material will pass. With Superpave, the use of the “nominal maximum aggregate size” is referenced. Nominal maximum aggregate size is the one sieve size larger than the first sieve in which at least 10% of the material is retained. How the HMA is to be used determines not only the

maximum aggregate size, but also the desired gradation (distribution of sizes smaller than the maximum).

2. **Cleanliness** - Foreign or deleterious/organic substances make some materials unsuitable for paving mixtures. Plastic fines are also unsuitable in paving aggregates.
3. **Toughness** - Toughness or hardness is the ability of the aggregate to resist crushing or disintegration during mixing, placing and compacting; or under traffic loading.
4. **Soundness** - Although similar to toughness, soundness is the aggregate's ability to resist deterioration caused by natural elements such as the weather.
5. **Particle shape** - The shapes of aggregate particles influence the asphalt mixture's overall strength and workability as well as the density achieved during compaction. When compacted, irregular angular shaped particles such as crushed stone tend to "lock" together and resist displacement. Flat and elongated aggregate particles should be avoided because during placement and compaction they tend to align themselves horizontally and do not "lock" together resulting in loss of stability and strength in the mix.
6. **Surface texture** - Workability and pavement strength are influenced by surface texture. A rough, sandpaper-like surface texture results in a higher strength than a smooth texture. Although smooth-faced aggregates are easy to coat with an asphalt film, they are generally not as good as rough surfaces. It is harder for the asphalt to "grip" the smooth surface.
7. **Absorption** - The porosity of an aggregate permits it to absorb asphalt and form a bond between the aggregate particle and the asphalt. Some degree of porosity is desired, but aggregates that are highly absorbent are generally not desirable.
8. **Stripping** - When the asphalt film separates from the aggregate because of the action of water, it is called stripping. Stripping usually starts at the bottom of the HMA layer and progresses upward. When stripping starts at the surface and progresses downward it results in raveling. Aggregates coated with too much dust also can cause poor bonding between the aggregate and the asphalt binder, which results in stripping. Some aggregates are more compatible with asphalt than others.

Aggregates readily susceptible to stripping action usually are not suitable for HMA paving mixes unless an anti-stripping agent or lime is used. High-silica-content-aggregates (silica) are not as compatible with asphalt as are aggregates that have high magnesium and iron (mafic).

CHAPTER TWO
PAVEMENT DESIGN
CONSIDERATIONS

CHAPTER TWO

PAVEMENT DESIGN CONSIDERATIONS

BACKGROUND OF THE DESIGN OF HOT MIX ASPHALT PAVEMENTS

HMA pavement design became well established in the early 1900's. The earliest of any record of pavement design date back as far as the 1860's. Tar was use as a binder for the first bituminous pavement. It was constructed in Washington DC around 1863. Just after the turn of the century in 1905 the first book documenting the significance of the role of fine aggregated fractions played in HMA was published.

In the early years of HMA design, there were several methods used to determine the asphalt content of HMA mixtures. The methods ranged from the simple "Pat Test", which was a visual determination of the amount of asphalt residual stain left on a piece of brown manila paper after being press against the HMA sample, to the more sophisticated methods of the last several decades like the Marshall and Hveem methods. The Marshall method was used by approximately 75% of the state highway departments. Most recently, the outcome from the SHRP program was the development of a newer, more accurate method that can more closely replicate the actual experience that the HMA pavement will experience in the field. This new method is the **Superpave** method. Today, nearly all states have implemented the **Superpave Mixture Design** system.

Figure 2-1 Full-depth Asphalt Pavement Section

DESIGN TYPES

In general, the design of a new HMA pavement structure involves two basic pavement types: (1) full-depth pavements (Figure 2-1), and (2) pavements with an untreated aggregate base course (Figure 2-2).

Full-depth asphalt pavement is one in which asphalt mixtures are used for courses above the subgrade. Such pavements are less affected by subgrade moisture and are more conducive to staged construction.

Full-depth HMA pavement is used in all types of highway construction and where high volumes of traffic and trucks are anticipated.

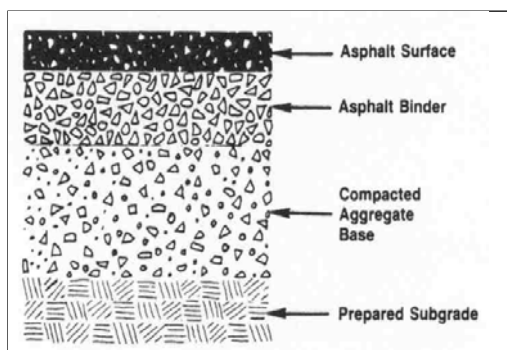
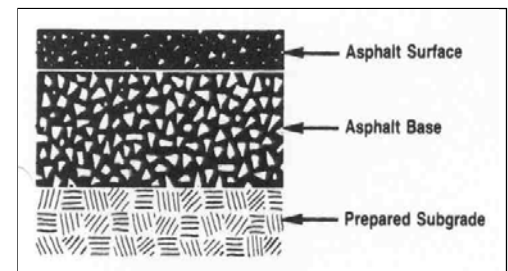

Untreated aggregate base pavements may be used where local aggregates and subsurface drainage conditions are suitable. The untreated aggregate base is placed and compacted on the prepared subgrade. An asphalt binder and surface course are then used to complete the pavement structure.

Using full depth or aggregate base section is site dependent. A qualified local consultant should be consulted to see which structural section is more appropriate when selecting the type of roadway structural section. Consideration should be given to the characteristics and properties of the subgrade soils.

OBJECTIVES OF MIX DESIGN

HMA mixtures should be properly designed in order to obtain the following desirable mix properties:

- **Resistance to Permanent Deformation (Rutting)** - The mix should not distort or displace when subjected to traffic especially when temperatures are elevated.
- **Fatigue Resistance** - The mix should not crack when subjected to repeated loads over a period of time.
- **Resistance to Low Temperature Cracking** - The mix should not crack during low or freezing temperature period of time.
- **Durability** - The HMA mixture must contain sufficient content of asphalt binder to ensure film coverage of the aggregate particles.
- **Resistance to Moisture Induced Damage** - The HMA mixture should be resistant to water causing the loss of adhesion between the aggregate surface and the asphalt binder. This is a property of the aggregate even though some asphalt binders are more susceptible to water than others. This phenomenon is called stripping.
- **Skid Resistance** - A mixture designed to provide sufficient resistance to skidding to permit normal turning and braking movement to occur.
- **Workability** - The HMA mixture must be capable of being placed and compacted with reasonable effort.

HOT MIX ASPHALT MIXTURE REQUIREMENTS

HMA is composed of aggregates with an asphalt binder and when required, certain anti-stripping additives. As the result of the recently completed Strategic Highway Research Program (SHRP), now commonly referred to as "Superpave", asphalt binders are classified based on their performance at both hot and cold temperatures. By carefully selecting quality aggregates and the correct Superpave Performance Graded (PG) asphalt binder, it is possible to produce high quality hot mix asphalt for a wide variety of climatic conditions in Colorado.

PG graded asphalt binders available in Colorado can be compared to previous viscosity graded binders. The comparisons were discussed in Chapter 1 and shown in Table 1-3.

When developing a HMA mix design for a project, a good reference to follow is the **Colorado Department of Transportation Standard Specifications, 2005 Edition** or the **Metropolitan Pavement Engineers Council's Pavement Design Standards and Construction Specifications** for the particular class and mixture size required. This will result in uniformity and economy because most Colorado contractors will have job mixes on several mixtures already prepared for state or local agency use. In the absence of a previously prepared job mix, the contractor or private testing laboratory should develop a job mix formula for the desired project, and intended use. The job mix formula should include the following information:

- Project information
- Name of Contractor
- Mix design method and compaction level

- Pit identification
- Bin combination percentages
- Physical properties of the aggregates (Quality properties - L.A. Abrasion, Fractured Faces, Sand Equivalent, Fine Aggregate Angularity...etc.)
- Aggregate specific gravity's - for each aggregate and composite material
- Asphalt binder grade and binder specific gravity
- Mixing and compaction temperatures
- Individual stockpile and composite gradations and 0.45 power curve
- Percent asphalt based on total weight
- Graphical plot of voids, VMA, VFA, unit weight (bulk) and unit weight (maximum theoretical)

The asphalt mix design or job mix formula should be based on Superpave technology. The compaction effort or number of gyrations of compaction at Design (N_{design}) for the Superpave compactor is varied to allow for different levels of compaction for different traffic loading (Equivalent Single Axle Loads - ESAL's). The various design gyrations used for Superpave are similar to different blow counts for the Marshall Method of Mix Designs. The new recommended N_{design} requirements (Table 2-1) for Superpave show the number of gyrations for different traffic loads (ESAL's).

Table 2-1
Traffic Loading vs. Design Compaction Gyrations

TRAFFIC LOAD ESAL's (millions)	Compaction Gyrations N_{design}
< 0.3 Paths and Non-vehicular Use	50
0.3 – 3	75
3 – 30	100
> 30	125

The HMA mixture gradations shown in Table 2-2, from **Table 703-3 "Master Range Table for Hot Bituminous Pavement" Colorado Department of Transportation Standard Specifications** are suggested guidelines for the type and mixture size specified.

Table 2-2
Master Range Table for Hot Mix Asphalt Pavement

Sieve Size	Percent by Weight Passing Square Mesh Sieves		
	Grading SX	Grading S	Grading SG ¹
37.5 mm (1 1/2")			100
25.0 mm (1")		100	90-100
19.0 mm (3/4")	100	90-100	
12.5 mm (1/2")	90-100	*	*
9.5 mm (3/8")	*	*	*
4.75 mm (#4)	*	*	*
2.36 mm (#8)	25-58	23-49	19-45
1.18 mm (#16)			
600µm (#30)	*	*	*
300µm (#50)			
150µm (#100)			
75µm (#200)	2-10	2-8	1-7

*These additional Form 43 screens will be established for the Contractor's Quality Control Testing using values from the As Used Gradation shown on the Design Mix.

¹For definitions of mix aggregate size see definitions below.

Superpave uses the following definitions for designating the aggregate mixture size for the various gradings shown in Table 2-2:

- *Maximum Size* - One sieve size larger than the nominal maximum size.
- *Nominal maximum Size* - One sieve size larger than the first sieve to retain more than 10 percent.

One very critical element of the Superpave system is the use of high quality aggregates. Quality requirements of aggregates (according to factors such as freeze and thaw, abrasion, plasticity index, etc.) for the various mixes should comply with the Colorado DOT Standard Specifications **Section 703.04 "Master Range Table for Hot Mix Asphalt"**. These aggregate requirements have been implemented as part of the Superpave mixture design system.

The fine and coarse aggregate angularity requirements are a part of insuring a high quality. The fine aggregate angularity requirement insures high quality sand (manufactured sand) in HMA mixtures. It is a critical requirement of the Superpave system. These aggregate quality requirements are summarized in the following table.

Table 2-3
Aggregate Properties for HMA Mixes

Aggregate Test Property	Coarse Retained on #4	Fine Passing #4
Fine Aggregate Angularity CP 5113 Method A	-	45% Minimum
Two Fractured Faces	80% minimum	-
L.A. Abrasion AASHTO T96	40% maximum	-
Flat & Elongated Pieces (Ratio 3:1) AASHTO M283	10% maximum	-
Sodium Sulfate Soundness AASHTO T104	12% maximum - Combined Coarse / Fine	
Adherent Coating (Dry Sieving) ASTM D5711	0.5%	-
Sand Equivalent, AASHTO T176	-	45% minimum

Plasticity Index, AASHTO T89, T90

The volumetric properties of the mix design are shown in Tables 2-4 and 2-5. Design air voids of the HMA should range from three percent to five percent with a target of four percent.

Table 2-4 VOIDS IN THE MINERAL AGGREGATE (VMA) REQUIREMENTS

Minimum VMA Requirements			
Nominal Maximum Size ¹ (in)	Design Air Voids ²		
	3.0%	4.0%	5.0%
1½"	10	11	12
1"	11	12	13
¾"	12	13	14
½"	13	14	15
⅜"	14	15	16

¹ The Nominal Maximum size is defined as one size larger than the first sieve to retain more than 10%.

² Interpolate specified VMA values for design air voids between those listed.

Voids Filled with Asphalt (VFA) are based on traffic levels (ESALs) and at 4% air voids. The VFA requirements are shown in Table 2-5.

Table 2-5
Voids Filled with Asphalt Binder Requirements

VFA Criteria	
ESAL's (millions)	Design VFA, %
< 0.3	70 – 80
0.3 – 3	65 – 78
3 – 30	65 – 75
> 30	65 – 75

SUPERPAVE GYRATORY COMPACTOR

In addition to a new and improved specification system for asphalt binders (Performance Grade - PG binders) and enhanced aggregate requirements, the Superpave mixtures design system is based on volumetric properties and utilizes a gyratory compactor (Superpave Gyratory Compactor - SGC) as the method of compaction. In contrast to the Marshall hammer, the Superpave Gyratory Compactor uses a kneading-type action to compact specimens in a way that is more consistent with in-place roadway compaction.



The number of gyrations (i.e. 68, 76, 86, 96, and 109 - Asphalt Institute's mix design procedure) is used to specify mixtures similar to the Marshall method of 50 Blow or 75 Blow design. The number of design gyrations (N_{design} or gyration level) is dependent on the traffic volume of the roadway. The higher the traffic volume, the higher the mix design gyration level (N_{design}). Table 2-6 identifies the N_{design} level vs. traffic levels that have been established by MGPEC in the Denver area for Superpave design mixes.

Table 2-6
MGPEC Superpave Mix Design Guidelines

Lift Thickness - in.		Aggregate Gradation Designation	
< 2		SX	
2 to 3		S	
4 to 4		SG	
Traffic Level	Traffic Loadings - ESALs	Gyration Level - N_{design}	Asphalt Binder Grade - PG
1	$< 0.3 \times 10^6$	68	58-28
2	0.3×10^6 to $< 1.0 \times 10^6$	76	58-28
3	1.0×10^6 to $< 3.0 \times 10^6$	86	58-28, 64-22, 76-28
4	3.0×10^6 to $< 1.0 \times 10^7$	96	64-22, 76-28
5	1.0×10^7 to $< 3.0 \times 10^7$	109	64-22, 76-28

Table 2-6 differs from the number of gyrations (N_{design}) shown in Table 2-1. The Metropolitan Government Pavement Engineers Council (MGPEC) specifications for 2001 are following the Asphalt Institute's mix design procedures. In 2002 they are adopting the gyration levels shown in Table 2-1. Agencies can use the gyration levels shown in Table 2-1 prior to 2002 and are encouraged to do so. The gyration levels shown in Table 2-1 are a result of a comparison of HMA mix properties at the various gyration levels to see the difference between each level mixture. The results of the comparison shown very little difference for the gyration ranges in mixture properties. The reduced number of gyration levels will result in lower cost mix designs in the future.

SPECIFYING A SUPERPAVE TYPE MIX

To specify a Superpave mixture design, three parameters are needed, namely:

- Mix type (SX, S, or SG, see Table 2-2)
- Gyration level (N_{design} - 68, 76, 86, 96 or 109) or (N_{design} - 50, 75, 100)

- Asphalt binder grade (PG: 64-22, 76-28, etc.)

Table 2-6 provides general guidance on specifying a Superpave mixture design. The guidance is consistent with the MGPEC design guidance.

For example, a 2-inch lift on a low volume roadway the following mix may be used:

- Aggregate gradation - SX
- N_{design} - 75 gyrations
- Asphalt binder grade - PG 58-28

MIX DESIGN SUBMITTAL

Each mix design prepared for a job should be submitted to the agency for review and approval. MGPEC has come up with a very useful summary form commonly referred to as **MGPEC Form #9**. This form summarizes the mixture design requirements for hot mix asphalt pavements (HMAP). A copy of this form is shown in Appendix B.

HMA PAVEMENT DESIGN

Many types of Hot Mix Asphalt (HMA) pavement structures exist, along with a number of different methods for designing the thickness of each element in any pavement. Fundamental to each design method are the following elements:

- Traffic loadings (volume and weight)
- Soil-support capability (including drainage considerations)
- Material specifications (aggregate and asphalt)

Each element is an important variable in the structural design process. The performance life of the HMA pavement depends on the close attention given to detail when analyzing traffic loading, soil-support capability, and material specifications.

The degree of detail needed in a specific design situation is related to the type of use intended for the pavement and the sensitivity of each variable. For example, a freeway design with large traffic volumes and heavily-loaded trucks requires a careful estimate of traffic; however, the number of bicycles and the loading on a bicycle path would not be significant factors in the path's structural design.

Colorado has an infinite variety of geology and soil conditions. As moisture and void contents vary within a given soil type, its strength characteristics will also change. Because drainage and soil-support capability are major factors in pavement life, it is important to know the quality of the supporting soil. This is especially true for a facility that will require a large construction investment. There should usually be a soil analysis during the thickness design process for almost all types of pavement.

On the other hand, a specific traffic study or soil analysis for a residential street or parking lot may not be deemed necessary in a certain location. For example, a location having uniform subgrade soils of known quality and a long and successful record of HMA pavements constructed for a specific use (e.g., driveways and residential streets), provides the designer with a background for selecting acceptable values.

In this Design Guide, pavement section thickness is determined using the following information:

- Subgrade strength, Resilient Modulus (M_R)
- Traffic analysis, ESALs
- Reliability level of pavement performance
- Structural Number, SN

In Chapter Three, strength coefficients are provided for various types of materials available for use in the pavement section. Chapter Three also provides thickness design procedures for determining alternate pavement sections.

TRAFFIC ANALYSIS

Because the primary function of a pavement is to transmit and distribute wheel loads of vehicles to the supporting subgrade, information about the traffic stream is required. Pavement should be designed to serve traffic needs over a period of years. The volume of traffic and the various types of vehicles using the facility should be estimated for the pavement's anticipated performance period.

A traffic assessment for an existing roadway, that is going to be improved, should be based on a detailed traffic count of the existing traffic. The existing traffic should be determined for the following three categories:

- Passenger cars and pickup trucks.
- Single unit trucks.
- Combination trucks.

Anticipated changes in traffic type should also be considered. Based on appropriate growth factors, the traffic volume is projected or inflated out to the end of the performance period, usually 20 years.

Local agencies should also consider the type and extent of construction traffic loads in new developments. Most often, the heaviest loadings occur during the build-out phase of the development. If these loadings are not taken into account in the pavement structure design, a shortened performance period of the pavement structure could result.



Since pavements are usually designed for periods ranging up to 20 years on the average or more, it is necessary to predict the ESAL's for this period of time, i.e., the performance period. The performance period, often referred to as the design period, is defined as the period of time that an initial pavement structure will last before reaching its terminal serviceability. Any performance period may be used with this Guide since design is based on the total number of equivalent single axle loads (ESAL's). However, experience may indicate a practical upper limit based on considerations other than traffic. The ESAL's for the performance period represent the cumulative number from the time the roadway is opened to traffic to the time when the serviceability is reduced to a terminal value (e.g., p_t equal to 2.5 or 2.0). If the traffic is underestimated, the actual time to p_t will probably be less than the predicted performance period, thereby resulting in increased maintenance and rehabilitation costs.

The maximum performance period to be used in designing for a particular pavement type should reflect agency experience. The performance period and corresponding design traffic should reflect real-life experience. The performance period should not be confused with the pavement life. The pavement life may be extended by periodic rehabilitation of the surface or pavement structure.

In the case of a new roadway a traffic assignment is based on:

- Historic records of traffic volumes on comparable types of roadways.
- The percentage of single unit and combination trucks.

The equivalent loads derived from the many traffic prediction procedures represent the totals for all lanes for both directions of travel. This traffic must be distributed by direction and by lanes for design purposes. Directional distribution is usually made by assigning 50 percent of the traffic to each direction, unless available measured traffic data warrant some other distribution. In regard to lane distribution, 100 percent of the traffic in one direction is often assigned to each of the lanes in that direction for purposes of structural design if measured distributions are not available.

For purposes of pavement structure design, it is necessary to estimate the cumulative number of 18-kip equivalent single axle loads (ESAL's) for the design (performance) period. The number of ESAL's may or may not be proportional to the average daily traffic. *Truck traffic is the essential information required to calculate ESAL's; it is therefore very important to correctly estimate future truck traffic for the facility during the design period.* The effects of truck traffic on a pavement can be dramatic. Tests have shown that a single-unit, fully loaded, 80,000 pound truck can cause pavement damage equivalent to that caused by 6,000 automobiles. This illustrates why carefully made estimates of expected traffic are critical to proper pavement design.

The accepted traffic analysis procedure currently used by CDOT is under review by both Federal Highway Administration (FHWA) and the Department. Some changes may result, but for this edition of the Design Guide the parameters used to determine the traffic volume for design purposes is based on current methods. Based on these current methods, several important parameters need to be determined:

- **Design Traffic** - is determined based on the traffic volume on comparable types of pavement and types and numbers of trucks expected to operate on the roadway over the performance period of the facility (usually twenty but sometimes ten years).
- **Average Daily Traffic (ADT)** - the amount of daily traffic determined for the first year plus the projected average amount of daily traffic for the last year of the design period divided by two (ADT for the midpoint of the design period).
- **Equivalent Single Axle Load (ESAL)** - the same as the Equivalent Daily Load Application (EDLA) which is the equivalent number of applications of an 18,000 pound, single axle load during an average 24 hour period.
- **Total ESALs** - The total ESALs is the ESAL value times 365 days per year times the number of years in



the design period adjusted by a traffic lane factor.

CDOT uses a five step procedure to predict the design total ESAL's used in pavement section design. The five steps are discussed below.

Step 1. Determine the Average Daily Traffic (ADT) for the first year and the last year of the design period. Use the appropriate growth factor for the last year of the design period. Calculate the ADT for the midpoint of the design period by adding the ADT of the first year and the ADT of the last year and divide by two.

Step 2. Separate the ADT of the midpoint by classification of vehicle. The ADT is separated in to the following three classifications:

- Passenger cars and pickup trucks.
- Single unit trucks.
- Combination trucks.

Step 3. Multiply the number of vehicles in each classification by the appropriate 18k equivalency factor. Table 2-7 show the equivalency factors determined by a study of Colorado traffic in 1987. The damaging effect of an axle is different for a flexible pavement and a rigid pavement; therefore there are different equivalency numbers for the two pavements.

Table 2-7
18 Kip Equivalency Factor for Pavement Types

Vehicle Classification	Flexible Pavement	Rigid Pavement
Passenger cars & pickup trucks	0.003	0.003
Single unit trucks	0.249	0.285
Combination trucks	1.087	1.692

Add the product of each equivalency factor and number of vehicles to yield a single number of ESALs for each pavement type.

Step 4. Multiply this number by 365 (days in a year) and the number of years in the design period.

Step 5. Multiply the 18k ESAL's for the roadway by the lane factor in Table 2-8. This will be the 18k ESAL for the design lane over the design period. Table 2-8 shows the lane factor that correlates to the number of lanes per direction. Lane Factors from Total 18k ESAL to Design Lane 18k ESAL

Lanes per Direction	Multiplication Factor
1	0.60
2	0.45
3	0.30
4	0.25

When traffic data is not available, such as for a proposed new residential land development, estimates of traffic volumes can be determined for local roads and collectors based on the following formula (2-1). This formula (2-1) was developed by CDOT from actual studies of traffic volumes generated by new developments. Arterial roads should have traffic data collected.

$$18k \text{ ESAL}_{20} = 62,000 + 80R \quad (2-1)$$

Where: 18K ESAL₂₀ is the number of 18 kip equivalent single axle loads for the design period (20 years).
R is the number of residential density units served by the roadway.

For new commercial areas where the roadways provide access to retail stores, businesses, office and other commercial areas, the following formula (2-2) can be used to estimate traffic volumes. These types of roadways receive a large mix of residential traffic along with trash trucks and delivery trucks. The formula (2) can be used for roadways with both commercial and residential traffic, but should not be used for commercial areas greater than ten acres. If the area is greater than ten acres, a traffic study should be conducted.

$$18k \text{ ESAL}_{20} = 62,000 + 80R + 260,000 C_A \quad (2-2)$$

Where: C_A is the acreage of the commercial property served by the roadway.

In industrial areas roadways provide access to property zoned for industrial use, such as, manufacturing, distribution and warehousing. Industrial roadways are typically subjected to some heavy truck loads, will also serve commercial areas and may serve some residential areas. Formula (2-3) should be not be used for an area with commercial and industrial uses larger than ten acres. Larger areas than ten acres, a traffic study should be done.

$$18k \text{ ESAL}_{20} = 62,000 + 80R + 260,000 C_A + 400,000 I_A \quad (2-3)$$

Where: I_A is the acreage of industrial property served by the roadway.

Since pavements are designed to handle the number of ESAL's it will experience for its performance period, when estimating traffic, detail should be given to estimating intersection traffic volumes. *Intersections not only have to handle the traffic loadings of the roadway under design but also have to handle the traffic volume of the cross roadway. The cross traffic needs to be accounted for as part of the traffic volume of the project for that intersection.* An in-depth discussion of intersection pavement design is included in Chapter 7.

In The Asphalt Institute's "**HMA Pavement Thickness Design Guideline (IS-181)**", traffic is separated into classes. This Design Guide follows the Institute's traffic class style by breaking traffic into six classes, I through VI. Each class is defined by an average daily traffic range, the average number of heavy trucks expected on the pavement during the design period, the assigned ESAL's, and the appropriate type of street or highway.

TRAFFIC CLASSIFICATIONS

CLASS I - (Very Light) Less than 50 autos per day, less than 7,000 heavy trucks expected during design period. Total ESAL's: < 0.3 million. Typical use areas are as follows:

Parking lots, driveways	Light traffic farm roads
School areas and playgrounds	Seasonal recreational roads
Sidewalks and bicycle paths	Golf cart paths
Tennis courts	

CLASS II - (Light) Up to 200 autos per day, 7,000 to 15,000 trucks expected during the design period. Total ESAL's: 0.3 to 0.5 million. Typical use areas are as follows:

Residential streets	rural farm roads
Parking lots of less than 500 stalls	

CLASS III - (Medium) Up to 700 autos per day, 70,000 to 150,000 trucks expected during design period. Total ESAL's: 0.5 to 1.0 million. Typical use areas are as follows:

Urban minor collector streets	rural minor collector streets
Parking lots - more than 500 stalls	

CLASS IV - (Medium) Up to 4,500 autos per day, 700,000 to 1,500,000 trucks expected during design period. Total ESAL's: 0.5 to 1.0 Million. Typical use areas are as follows:

Urban minor arterial and light industrial streets
Rural major collector and minor arterial highways
Industrial lots, truck stalls
Bus driveways and loading zones

CLASS V - (Heavy) Up to 9,500 autos per day, 2,000,000 to 4,500,000 trucks expected during design period. ESAL's 1.0 - 10 Million. Typical use areas are as follows:

Urban freeways, expressways and other principal arterial highways
Rural interstate and other principal arterial highways
Local industrial streets
Major service drives or entrances

CLASS VI - (Very Heavy) Unlimited autos, 7,000,000 to 15,000,000 trucks expected during design period. ESAL's > 10 Million. Typical use areas are as follows:

Urban interstate highways	some industrial roads
---------------------------	-----------------------

For more information on this subject refer to the Asphalt Institute's publications "***Thickness Design - HMA pavements for Highways and Streets (MS-1)***" and "***HMA Pavement Thickness Design (IS-181)***". This publication may be obtained by contacting the Asphalt Institute at www.asphaltinstitute.org.

SOIL SUPPORT CAPABILITY

The ability of the subgrade to support loads transmitted from the pavement is one of the most important factors in determining pavement thickness. The subgrade should serve as a working platform to support construction equipment and as a foundation for the pavement structure that supports and distributes traffic loads. It is essential to evaluate the strength of the subgrade before beginning the structural design of the pavement. Figure 2-3 shows the spread of a wheel load through the pavement structure and on to the subgrade.

If sufficient pavement thickness is not provided, the applied loads could cause greater stresses on the subgrade than it can resist. This may result in deflection of the pavement and ultimately in its failure.

In street and highway construction, the subgrade provides the foundation for the pavement. Different types of soils have different abilities to provide support. A sandy soil, for example, will support greater loads without deformation than a silty clay soil. Thus, for any given traffic volume and weight of vehicles using the roadway, a greater pavement thickness should be provided on clay soils than on sandy soils.

SOIL CLASSIFICATIONS

Soil is classified for road and street construction in order to predict subgrade performance on the basis of a few simple tests. The American Association of State and Highway Transportation Officials (AASHTO) classification system for soils is commonly used as an indicator for subgrade-support value.

According to the AASHTO system, soils that have approximately the same general load-carrying capabilities are grouped in classifications of A-1 through A-7 as shown in Table 2-9. In general, the best highway subgrade soils are A-1, and the worst are A-7. The classification is based on a sieve analysis, plasticity index, and liquid limit of the soil being tested.

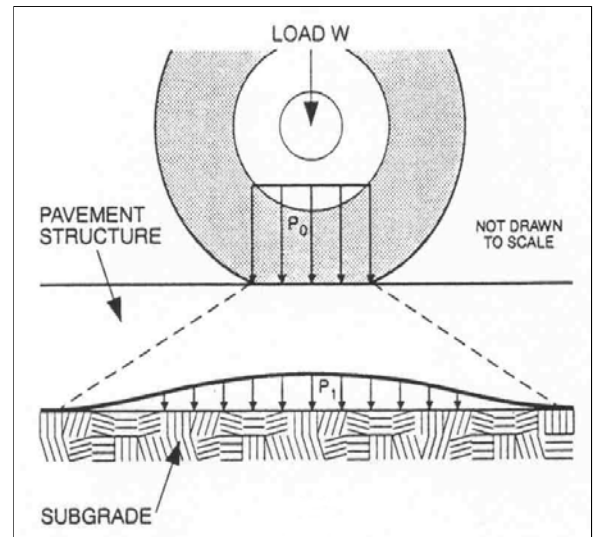

Table 2-9 Classification of Soil-Aggregate Mixtures with Suggested Subgroups

General Classification	Granular Materials (35% or less passing No. 200)							Silt-Clay Materials (More than 35% passing No. 200)			
	A-1		A-3	A-2				A-4	A-5	A-6	A-7
Group Classification	A-1-a	A-1-b		A-2-4	A-2-5	A-2-6	A-2-7				A-7-5; A-7-6
Sieve Analysis: Percent Passing:											
No. 10	50 Max										
No. 40	30 Max	50 Max	51 Min								
No. 200	15 Max	25 Max	10 Max	35 Max	35 Max	35 Max	35 Max	36 Min	36 Min	36 Min	36 Min
Characteristics of fraction passing No. 40:											
Liquid Limit				40 Max	41 Min	40 Max	41 Min	40 Max	41 Min	40 Max	41 Min
Plasticity Index	6 Max		N.P.	10 Max	10 Max	11 Min	11 Min	10 Max	10 Max	11 Min	11 Min
Usual types of Significant Constituent Materials	Stone Fragments, Gravel & Sand		Fine Sand	Silty or Clayey Gravel and Sand				Silty Soils		Clayey Soils	
General Rating as Subgrade	Excellent to Good							Fair to Poor		Poor	

SUBGRADE STRENGTH

Within a given soil group the strength properties of the soil are a function of the density, void ratio, and moisture content. Fine grained soils are much more influenced by changes in these properties than are coarse grained soils. Because thickness calculations depend on the strength of the finished subgrade, the soil should be tested for this information. Tests are based on bearing capacity related to the moisture and density of the soil. The California Bearing Ratio (CBR) is one of the most widely used methods of measuring the strength of the subgrade. The CBR value can be measured directly on the in-situ soils in the field or on remolded samples in the laboratory. Determining an R-Value (Hveem method) is another method of measuring the subgrade strength, but can only be performed on a laboratory prepared sample.

The lower the CBR or R-Value of a particular soil, the less strength it has to support the pavement. This means that a thicker pavement structure is needed on a soil with a low CBR or R-Value than on a soil with a high CBR or R-Value. Generally, clays have a CBR classification of six or less. Silty loam and sandy loam soils are next with CBR values of six to eight. The best soils for road building purposes are the sands and gravels whose CBR ratings normally exceed ten. Corresponding R-Values are ten or less for clays, ten to thirty for silty loam and sandy loam soils, and thirty or higher for sands and gravels.

The change in pavement thickness needed to carry a given traffic load is not directly proportional to the change in CBR or R-value of the subgrade soil. For example, a one-unit change in CBR from five to four requires a greater increase in pavement thickness than does a one-unit CBR change from ten to nine.

For the design method presented in this Guide, CBR and R-Values are converted to a Resilient Modulus (M_R) so the CDOT design procedure, which parallels the AASHTO design procedure, can be used. M_R is a measure of the elastic property of soil recognizing certain nonlinear characteristics. M_R can be used directly for the design of flexible pavements. Direct measurement of subgrade reaction can be made if such procedures are considered preferable to the designer.

The resilient modulus was selected to replace a soil support value for the following reasons:

- It indicates a basic material property which can be used in mechanistic analysis of multilayered systems for predicting roughness, cracking, rutting, faulting, etc.

- Methods for the determination of M_R are described in AASHTO T 274.

- It has been recognized internationally as a method of characterizing materials for use in pavement design and evaluation.

- Techniques are available for estimating the M_R properties of various materials in-place from nondestructive tests.

It is recognized that many agencies do not have equipment for performing the resilient modulus test. Therefore, suitable factors are reported which can be used to estimate M_R from standard CBR, R-value and soil index test results or values. The equations for converting CBR or R-values are presented in Chapter Three.

SOIL TESTING

A qualified laboratory should conduct tests to provide soil classification and subgrade strength information (such as the CBR or R-Values). Such testing is necessary to ensure a proper structural design and should be a part of all projects.

SUBGRADE CLASSES

For discussion in this guide, the soils have been divided into three classes: good (G), moderate (M), and poor (P). Typical CBR and R-Values are provided for these different subgrade classes.

Good (G) - Good subgrade soils retain a substantial amount of their load-supporting capacity when wet. Included in this subgrade class are the clean sands, sand-gravels, and those free of detrimental amounts of plastic materials. Excellent subgrade soils are relatively unaffected by moisture or frost and contain less than 15 percent passing a No. 200 mesh sieve. A soil classified as good will have a CBR value of 9 or greater or an R-Value of 30 or higher.

Moderate (M) - Moderate subgrade soils are those that retain a moderate degree of firmness under adverse moisture conditions. Included in this subgrade class are such soils as loams, silty sands, and sand gravels containing moderate amounts of clays and fine silts. When this soil becomes a cohesive material, it should have a minimum proctor density of 110 pounds per cubic foot. A soil classified as moderate will have a CBR value of six to eight or an R-Value in the range from ten to thirty.

Poor (P) - Poor subgrade soils are those that become quite soft and plastic when wet. Included in this subgrade class are those soils having appreciable amounts of clay and fine silt (50 percent or more passing a No. 200 sieve). The coarse silts and sandy loams may also exhibit poor bearing properties in areas where deep frost penetration into the subgrade is encountered for any appreciable periods of time. This also is true where the water table rises close to the surface during certain periods of the year. A soil classified as poor will have a CBR value of five or less or an R-Value of less than ten.

When fine grained soils are very moist or saturated it is recommended that the field CBR test method be used because it allows one to measure the actual in-situ strength of the soil.

Very poor soils (those with a CBR of 3 or lower or R-Values of 5 or less) often perform poorly as pavement subgrade. The performance of very poor soils can be stabilized with the addition of granular material. Lime, fly-ash, asphalt cement, Portland cement, and combinations of cement stabilizers also can be added to improve the subgrade support value. The selection of a stabilizing agent, the amount to use, and the application procedure depend on the soil classification and the subgrade-support value desired. These should be determined through appropriate laboratory testing and engineering evaluation. Chapter 4 provides a detailed discussion of subgrade modification.

The very poor soils can also be bridged using various types of geotextiles. The tensile strength of the geotextile provides the bridging action. Geosynthetics are discussed in Chapter 6.

SALVAGED AND RECLAIMED MATERIAL (RAP)

Recycling of reclaimed asphalt pavement (RAP) by using it in new HMA mixtures has become a routine and accepted process for use of the salvaged asphalt pavement. Recycling of existing pavement materials to produce new pavement materials results in considerable savings of material, money and energy. The HMA producer substitutes RAP for virgin materials at varying ratios from 10% to 50% by weight. A newly developed CDOT specification allows up to 25% RAP in HMA mixes under certain restrictions.

RAP is typically generated through two reclamation procedures: milling and full-depth removal.

Milling is frequently used in a rehabilitation program where an upper layer of existing pavement is removed and replaced with new pavement to lengthen the pavement's service life. Milled RAP has the additional benefit of being ready to recycle immediately without additional processing. RAP from a single layer typically has uniform properties (RAP gradation, aggregate gradation, asphalt content and asphalt characteristics). For this reason, millings are frequently segregated and identified in separate stockpiles at a storage location.

Pavement can also be removed completely in total reconstruction. Here, heavy construction equipment breaks the entire pavement structure into manageable slabs and loads them into trucks for transportation to a processing site. The slabs are then crushed to a usable size for recycling.

RAP can be used in Superpave mixes. Virgin material and RAP should meet applicable aggregated properties, gradation and volumetric properties. RAP gradations should be included in your calculations of mix gradation. RAP should be treated as a stockpiled aggregate. And when determining your trial asphalt content in the mixture, the asphalt content of the RAP needs to be taken into account. Some general requirements for using RAP are:

- 100 percent of the material has to pass the 50 mm (2 in.) Sieve;
- Deleterious materials are held to a maximum of two percent or as specified by the DOT;
- No particle in a RAP mix should exceed maximum aggregate size when it reaches a transport vehicle; and
- Maximum RAP aggregate size should be half the layer thickness.

The final product, whether it has RAP or not should have the same properties as a virgin mix.

RAP can be used in the production of HMA as well as in the base, binder, and surface courses. It can also be used as an enhanced base course by itself or in some cases as a surface treatment for very light traffic uses. When used by itself, it sometimes needs to be rejuvenated with an additive. Chapter 12 in this Guide is devoted to recycled materials.

DRAINAGE

GENERAL CONSIDERATIONS

Drainage of water from pavements has always been an important consideration in road design. However, current methods of design have often resulted in base courses that do not drain well. This excess water combined with increased traffic volumes and loads often leads to early pavement distress in the pavement structure.

Water enters the pavement structure in many ways, such as through cracks, joints, or pavement infiltration, or as ground water from an interrupted aquifer, high water table, localized springs or median or roadside irrigation systems.

Pavement engineers recognize the importance of good drainage in the design, construction, and maintenance of any pavement. Probably no other single factor plays such an important role in determining the ability of a pavement to provide trouble-free service throughout long periods of time. A detailed drainage study by a qualified drainage engineer should be part of the pavement design.

The accumulation of water in the subgrade, or in an untreated aggregate base course creates problems. When the soil is saturated, application of dynamic wheel loads induces pore pressures and lowers the resistance to shear forces. Some soils have a high volume change when water is added which causes differential heaving. The subsequent weakening of the pavement structure causes it to lose stability and its capability to support traffic loads.

Water in a pavement's asphalt layers combined with dynamic and repeated traffic loading can strip or separate the asphalt film from the aggregate. This reduces the load-carrying capacity of the mixture. When developing the features of a highway drainage system, it is important to consider the system's principal purposes:

- To collect and drain away both surface water and subsurface water,
- To lower the groundwater table, if necessary,
- To intercept water from surrounding areas and carry it away from the roadway and
- To prevent or retard erosion.

There are two basic categories of drainage - **surface and subsurface**. **Surface** drainage includes the disposal of water present on the pavement surface, shoulder surface, and the adjacent ground when sloped toward the pavement. **Subsurface** drainage deals with water in the surrounding soil, the subbase, base, and in the several pavement courses. Inadequate attention to either of these two drainage conditions can lead to premature pavement failure.

SURFACE DRAINAGE

In surface drainage conditions, the pavement and shoulders should be crowned or cross-sloped to facilitate the flow of water off of the roadway. Normally, the cross-slope moves the water to a curbed or inverted-shaped gutter and then off of the pavement into a storm sewer or flume to an open ditch.

On parking areas or playgrounds, the cross-slope or crown may be inverted to form a center swale whose flow maybe intercepted by a grated inlet to a storm sewer system.

Shoulders can best be drained if the entire shoulder width has an asphalt paved surface. If the shoulder is not asphalt, its cross-slope should be greater than the pavement slope in order to minimize seepage through the aggregate or grass shoulder.

Surface drainage from the pavement as well as from the adjacent land areas should be intercepted and disposed of properly. If a curbed section is provided, drainage is accumulated in the gutter area and periodically discharged into either a pavement inlet or an open ditch through a flume. The determination of inlet locations requires technical calculations and studies by a qualified drainage engineer to avoid an intolerable spread of water on the pavement.

Drainage ditches are constructed along the edges of non-curbed roadway sections. Water flowing from the pavement and shoulder surfaces moves down the roadway foreslope into the ditch flowline. A back slope leads from the flow line of the ditch up to intercept the adjacent land. The adjacent land is frequently sloped toward the ditch and can contribute to a sizable portion of the drainage volume and flow.

Good design practices will provide cross-slopes both on the surface and in the underlying pavement courses and subgrade (See Figure 2-6). In this way, water will not accumulate but will flow laterally to the sides.

SUBSURFACE DRAINAGE

Subsurface water is free water that percolates through, or is contained in, the soil beneath the surface. When it emerges or escapes from the soil, it is referred to as seepage water. The point of emergence is called a seepage area or a spring.

Pavement subsurface water usually is present as free water that flows under the force of gravity or as capillary water that moves under capillary action in the soil.

Water could rise from the underlying soil through the subgrade and into an untreated aggregate base course. This free water could move readily through an untreated aggregate base to a low point on the profile. If steep grades are present, and the subsurface water flowing in an untreated aggregate base to the low spot is not intercepted, a hydrostatic head may result. This lifting force will cause a failure of the pavement structure. Water in the pavement courses also may contribute to the stripping of asphalt films from the aggregate particles.

Aggregate base provides a drainable base for the pavement, providing a method to remove water is also provided. This concept is shown in Figure 2-6. The decision to use an aggregate base type pavement structure (Figure 2-2) or a full depth type pavement structure (Figure 2-1) should be evaluated by a qualified consultant.

SUBDRAINS

When the potential exists for water collecting in the structural elements of the pavement, subdrains are required. Identification of these areas and determination of drain locations require the technical expertise and insight of a drainage engineer and/or qualified technician. The type of drain, choice of drain filter material and the design of the drainage system should be given careful attention. Perforated and/or slotted pipe usually serve to move the free water from the trouble spot to a drainage system.

CHECK DRAINAGE DURING CONSTRUCTION

Regardless of the care used in the preliminary investigation, in the soil survey, and in the pavement structure's design, it is usually not possible to determine from borings the exact elevation of water-bearing strata or the rate of flow that may develop. Spring runoff and summer irrigation can cause water tables to fluctuate substantially. For these reasons, it is essential that the engineer reevaluate the conditions and check the need for, and the adequacy of, any subsurface drainage indicated on the plans.

Soil conditions should be observed during the grading and subgrade preparation work. Any wet, soft, or spongy areas encountered at grade should be investigated and provisions made for their proper drainage. Even a minor rate of seepage may build up to a large quantity of water over a period of time if a means of escape is not provided. Such a soft spot usually forewarns of a structural failure at a later date - even shortly after traffic has used the new facility. After the pavement is in place, corrective measures are costly, create traffic problems, and can cause poor public relations.

Figure 2-6 Schematic of a Roadway Drainage Scheme

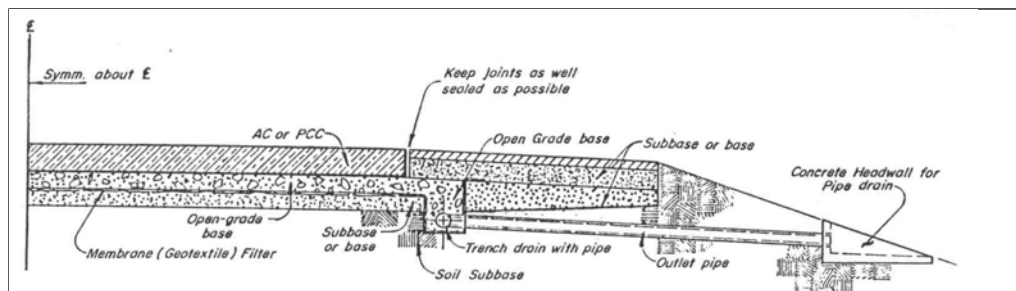

CHAPTER THREE

THICKNESS DESIGN

CHAPTER THREE

THICKNESS DESIGN

GENERAL CONSIDERATIONS

Several procedures can be used to calculate the thickness of the proposed asphalt pavement. Most are based on the volume and weight of the traffic that will use the facility and on the load-supporting capability of the underlying soil.

The AASHTO Road Test and other studies have indicated that heavy vehicle wheel loads cause greater damage to roads than do light loads. Thus, where large volumes of traffic with heavily loaded trucks are anticipated, an in-depth analysis of the pavement thickness is important. Because of the potential for heavy loadings, a traffic analysis is an important part of the preparation for thickness design. Similarly, knowledge of the load bearing capability of the soil is an important aspect of the structural design process. The lack of a soil study with appropriate corrective action could significantly shorten the life of a poorly designed pavement.



All of the design procedures available for a structural thickness analysis cannot be included here. The pavement thickness design approach discussed in this Guide parallels the design procedure in the **AASHTO Guide for Design of Pavement Structures**, but does not go the depth that the AASHTO guide does. If additional pavement design information and methods are sought, the Asphalt Institute's **Thickness Design Guide (MS 1)** and their **Simplified and Abridged Version** published in **Information Series No. 18 (IS-181)** are good references. CDOT's thickness

design procedure parallels that of the AASHTO guide procedures. These Guides are based on mechanistic/empirical design models, and they use nomographs to attain pavement thickness. Several computer programs for designing pavements (including Asphalt Institute (www.asphaltinstitute.com) and AASHTO (DARWin, www.aashto.org) programs) are also available. For specific design and thickness questions, contact a qualified geotechnical consultant.

For this guide, the AASHTO Interim Guide method for determining pavement thickness has been chosen. This method uses nomographs (design charts) to determine the pavement thickness as well as the other components of the pavement structure. The nomographs were developed from AASHTO road test which encompassed five areas that are discussed in the following section.

PAVEMENT THICKNESS DESIGN

For this guide, a simple to use **nomograph method** has been chosen for pavement thickness design. There are five important values that need to be determined or known to use the nomograph method, they are:

1. Subgrade Strength – Resilient Modulus (M_R)
2. Traffic analysis, ESALs
3. Reliability Level of Pavement Performance
4. Overall standard Deviation, (AASHTO recommend number 0.44)
5. Structural Number – SN

Each of the above factors is discussed in the following sections followed by an example of how each is used to determine the pavement structural thickness.

SUBGRADE STRENGTH

The performance of a flexible pavement structure is directly related to the physical properties and supporting strength of the roadbed soil. The effect of less satisfactory soils can be compensated for by increasing the thickness or the strength of the pavement structure.

In Colorado subgrade strength is usually determine by the California Bearing Ratio test (CBR) or the Hveem test (R-Value) methods. The CBR and R-Values need to be determined by a qualified laboratory for the actual soil from the project. It is important that samples be obtained from the project site. The test method to be used should be one of the following:

- Colorado Procedure CP-L 3101 ~ ***Strength Determination of Compacted Soils And Aggregates by R-Value***
- ASTM D 1883–94 ~ ***Standard Test Method For CBR (California Bearing Ratio) of Laboratory Compacted Samples***
- ASTM D 4429–93 ~ ***Standard Test Method For CBR (California Bearing Ratio) of Soils in Place***



Because of the highly variable nature of soils in Colorado both AASHTO and Unified soil classifications should be determined in the laboratory for several samples that accurately represent the soil conditions for the proposed project. During exploration and sampling moisture contents and densities of the in-place soils need to be measured. Potential saturation levels of the subgrade also should be considered. **If the in-place soils are saturated, or their moisture content will potentially be higher than optimum or the densities are below the maximum density based on ASTM D 698 or D 1557, the laboratory methods for measuring CBR or R-Value may not be an accurate measurement of the strength of the subgrade. In this case the field CBR method would be the preferred method of measuring the subgrade strength.**

If the laboratory method is to be used, the soil classifications are used to group the soils into soil groups. The poorer quality soil groups should be chosen for further testing to determine their CBR or R-Value. If it appears to be necessary, the field method for CBR can be measured on select locations during the initial exploration.

The design nomograph used in this Guide uses the Resilient Modulus (M_R) for subgrade strength (discussed in Chapter 2). Since most soil strength test conducted in Colorado use either the CBR method or the Hveem method, the CBR value or the R-Value will need to be converted to Resilient Modulus (M_R) value.

It is recognized that most agencies or qualified consultants do not have equipment for performing the resilient modulus test. Therefore, suitable factors have been reported (AASHTO and CDOT design methods) which can be used to estimate M_R from CBR and R-Values.

CBR value correlation to an M_R is shown by the following relationship (3-1). This relationship was reported by Keukelom and Klomp between the Corps of Engineers CBR value, using dynamic compaction and the in situ modulus for soil.

$$M_R \text{ (psi)} = 1500 \times \text{CBR} \quad (3-1)$$

The data from which this correlation was developed ranged from 750 to 3,000 times CBR. This relationship has been used extensively by design agencies and researchers and is considered reasonable for fine-grained soil with a soaked CBR of 10 or less.

The relationship used by the Colorado Department of Transportation for correlating the approximate value of M_R to an R-Value is given by the following relationship (3-2).

$$M_R \text{ (psi)} = 10^P \quad (3-2)$$

Where: $P = (S_1 + 18.72) \div 6.24$

$S_1 = [(R-5) \div 11.29] + 3$

S_1 is the soil support value.

R is the R-Value obtained from the Hveem stabilometer.

Designers should note that although the Hveem equipment is used for purposes of performing pavement design, the result of the Hveem test is not the Resilient Modulus. It is recommended that documentation of the pavement design show that when the Hveem test is used, the R-Value is measured and the Resilient Modulus is an approximation from the above correlation formula.

TRAFFIC (ESALs)

The destructive effect of repeated wheel loads is the major factor that contributes to the failure of roadway pavement structure. Since both the magnitude of the load and the number of repetitions are important, provision is made in the design procedure to allow for the effects of the number and weight of axle loads expected during the design period.

The traffic data figures to be incorporated into the design procedure are in the form of 18 kip equivalent single axle load applications (18k ESAL). All vehicular traffic on the design roadway is projected for the design period in the categories of passenger cars, single unit trucks and combination trucks. The actual projected traffic volumes for each category are weighted by the appropriate load equivalence factors and converted to a cumulative total 18k ESAL. Adjustments to this value will be made for directional and lane distribution and then entered in the pavement design equation.

As discussed in Chapter Two, the design procedure separates traffic into six classes (I through VI). Each class is defined by the number of autos per day, the average daily number of heavy trucks expected on the facility during the design period, and the type of street or highway. Each traffic class has been assigned a total ESAL value range. A comprehensive traffic study should be performed to determine the class of roadway or highway that will be needed for the design. The total ESAL value for a required class of roadway or highway is used for the design.

Caution should be used when measuring current traffic volumes. Normal growth, new development and any other special impacts that might change the roadway usage and future traffic volumes needs to be considered. Oftentimes, it is not possible to accurately predict some unknown future development that could result in traffic in excess of an existing roadway design. There could be special provisions that exist in planning and zoning regulations that allow a city or county to circulate a proposed new developments' impact on existing roadways. Intersecting roadway volumes should be taken into account when designing intersections. **Not taking the cross traffic volumes into the design, premature failure of the intersection pavement could result.**

DRAINAGE CHARACTERISTICS

Drainage factors in flexible pavement design are taken into account through the use of modified structural layer coefficients. A higher effective structural layer coefficient would be used for improved drainage conditions. The factor for modifying the structural layer coefficient is called a m_i value. This drainage coefficient (m_2 , m_3) has been integrated into the structural number (SN) equation (3-3), shown below, used to calculate the thickness of the various layers of the pavement structure.

$$SN = a_1D_1 + a_2D_2m_2 + a_3D_3m_3 \quad (3-3)$$

Where:	$a_1, a_2, a_3 =$	structural layer coefficients
	$D_1 =$	thickness of HMA surface course in inches
	$D_2 =$	thickness of base course in inches
	$D_3 =$	thickness of subbase course in inches
	$m_2 =$	drainage coefficient of base course
	$m_3 =$	drainage coefficient of subbase course

Drainage coefficients for different quality of drainage and the percent of time during the year the pavement structure would be normally exposed to moisture levels approaching saturation are shown in Table 3-1. Obviously, the latter is dependent on the average yearly rainfall and the prevailing drainage conditions. It is

important to note that these values apply only to the effects of drainage on untreated base and subbase layers. Although improved drainage is certainly beneficial to stabilized or treated materials, the effects on performance of flexible pavement are not as profound as those quantified in the Table 3-1.

Table 3-1
 m_i Values¹ for Modifying Structural Layer Coefficients
 Of Untreated Base and Subbase Materials in Flexible Pavements

Quality of Drainage	Percent of Time Pavement Structure is Exposed to Moisture Levels Approaching Saturation			
	Less than 1%	1% - 5%	5% - 25%	Greater than 25%
Excellent	1.40 - 1.35	1.35 - 1.30	1.30 - 1.20	1.20
Good	1.35 - 1.25	1.25 - 1.15	1.15 - 1.00	1.00
Fair	1.25 - 1.15	1.15 - 1.05	1.00 - 0.80	0.80
Poor	1.15 - 1.05	1.05 - 0.80	0.80 - 0.60	0.60
Very Poor	1.05 - 0.95	0.95 - 0.75	0.75 - 0.40	0.40

¹Designers should use a value of $m_i = 1.0$ unless specific drainage information indicates otherwise.

It is important to understand the roadway geometry, particularly the drainage gradients on the roadway prism when selecting base type. As long as the base will be able to carry drainage away from the pavement structure, a gravel base will perform adequately. Although improved drainage is certainly beneficial to stabilized or treated materials, the effects on performance of the flexible pavements are not as profound as those quantified in the above table.

General definitions for “Quality of Drainage”, shown in the above table corresponding to different drainage levels within the pavement structure, are shown in Table 3-2. For comparison purposes, the drainage condition at the AASHTO Road Test are considered to be fair, i.e., free water was removed within one week.

Table 3-2
 Drainage Quality

Quality of Drainage	Water Removed Within
Excellent	2 hours
Good	1 day
Fair	1 week
Poor	1 month
Very Poor	water will not drain

RELIABILITY LEVEL OF PAVEMENT PERFORMANCE

The concept of pavement reliability can be described in several ways and in terms of the components considered in the pavements design. Reliability can be defined as:

- The probability that the pavement system will perform its intended function over its design period or time and under the conditions or environment encountered during operation.
- The probability that serviceability will be maintained at adequate levels from a user’s point of view, throughout the design period of the facility.

- The probability that the load applications a pavement can withstand in reaching a specified minimum serviceability level are not exceeded by the number of load applications that are actually applied to the pavement.

Pavement design procedures prior to 1986 had essentially contained an inherent 50% reliability factor. The new design procedures presented herein, paralleling the 1993 AASHTO Design Guide, allows the designer to select a risk factor (reliability) that the assumptions and data he uses in the design process will provide a pavement system that will meet expectations. Table 3-3 presents a range of Reliability factors that a designer can choose corresponding to the type of facility being designed.

Table 3-3
Reliability (Risk)

Functional Classification	Urban	Rural
Interstate Freeway	85 - 95	80 - 95
Principal Arterials	80 - 95	70 - 95
Minor Arterials	70 - 95	60 - 90
Collectors	50 - 90	50 - 85
Local	50 - 80	50 - 75

The reliability component gives the designer the option of incorporating a risk reduction factor into the pavement design process. The reliability factor is determined based on the functional classification of the roadway and whether it is in an urban or rural location. Reliability is not dependent on type of pavement or type of project. Reliability is most closely related to the traffic conditions and 18k ESALs. The selection of a Reliability factor should be consistent throughout the design and analysis of the project. Once the Reliability factor is selected, it should be used for the pavement type selection and design calculations.

For a given reliability level, the reliability factor is a function of the overall standard deviation (S_o) that accounts for both chance variation in the traffic prediction and normal variation in pavements performance prediction. It is important to note that by treating design uncertainty as a separate factor, the designer should no longer use “conservative” estimates for the other design input requirements. Rather than conservative values, the designer should use his best estimate of mean or average value for each input value. The selected level of reliability and overall standard deviation will account for the combined effect of the variation of the design variables.

A standard deviation (S_o) should be selected that representative of local conditions. Values of S_o developed at the AASHTO Road Test did not include traffic error. However, the performance prediction error developed at the Road Test was 0.35 for flexible pavement. This corresponds to a total standard deviation for traffic of 0.45. CDOT uses a **value** for S_o of 0.44.

STRUCTURAL NUMBER (SN)

The serviceability of a pavement is defined as its ability to serve the type of traffic (automobiles and trucks) which use the facility at any specific time. The primary measure of serviceability is the Present Serviceability Index (PSI), which ranges from 0 (impossible road) to 5 (perfect road). The basic design philosophy of this Guide is the serviceability-performance concept, which provides a means of designing a pavement based on a specific total traffic volume and a minimum level of serviceability desired at the end of the performance period. Serviceability indexes for the various pavement conditions are shown in Table 3-4.

Table 3-4
Pavement Serviceability Index

Condition	Index
Very Poor	0 - 1
Poor	1 - 2
Fair	2 - 3
Good	3 - 4
Very Good	4 - 5

Selection of the lowest allowable PSI or terminal serviceability index (p_t) is based on the lowest index that will be tolerated before rehabilitation, resurfacing, or reconstruction becomes necessary. An index of 2.5 or higher is suggested for design of high volume roadways and 2.0 for low volume roadways. One criterion for identifying a minimum level of serviceability may be established on the basis of public acceptance. Shown in Table 3-5 are a general guideline for minimum levels of p_t obtained from studies in connection with an AASHTO Road Test. The results shown in Table 3-5 indicate that a p_t of less than 2.5 is not acceptable to the general public. A little over 50% of people survey said that a serviceability index of less than 2.5 is also unacceptable.

Table 3-5
Serviceability Level Acceptance

Terminal Serviceability Index	Percent of People Stating Unacceptable
3.0	12
2.5	55
2.0	85

The serviceability Index at initial construction will normally fall in the range of 4.2 to 4.6 and generally can be assumed to be 4.5. The serviceability index at the end of the design period is the worst case allowable condition that the pavement may reach. The objective is to build a pavement that has a high Serviceability Index at initial construction and an Index at the end of the design period of not less than 2.0 for low volume and 2.5 for high volume. A low volume being a road with a current ADT of less than 750; and a high volume being a road with a current ADT of 750 or greater. For relatively minor highways where economics dictate that the initial capital outlay be kept at a minimum, it is suggested that this be accomplished by reducing the design period or the total traffic volume, rather than by designing for a terminal serviceability less than 2.0.

Design Serviceability loss may be affected by components other than traffic; the roadbed soils may influence the loss if problems are anticipated such as frost heaving or moisture swelling. It is recommended to remove and replace any subgrade soils that are susceptible to the detrimental effects of frost or swelling. If removal is not practical, in-place treatment such as a lime-treated subgrade is recommended.

FLEXIBLE PAVEMENT DESIGN

Flexible pavement design is based on identifying a flexible pavements structural number (SN) to withstand the projected level of axle load traffic over the design period of the facility. The SN is obtained from a nomograph that relates the component of the pavement structure that can withstand the project ESALs. The nomograph use in the AASHTO and CDOT procedures for determining the structural number of a pavement structure is shown in Figure 3-1.

The SN obtained from Figure 3-1 is then used in equation 3-3 along with the various strength coefficients and drainage coefficient to determine the thickness of the various layer of the pavement structure.

STRENGTH COEFFICIENTS

Table 3-6 lists the strength coefficients ($a_1, a_2, a_3, \dots, a_n$) for various potential components of the pavement section. The Strength Coefficients shown in the table are use in the Structural Number equation (3-3) to determine the thickness of the various layers of the pavement structure. How these coefficients are used is shown in the section on PAVEMENT DESIGN PROCEDURES, starting on page 3-10.

Figure 3-1 Design Nomograph for Flexible Pavement

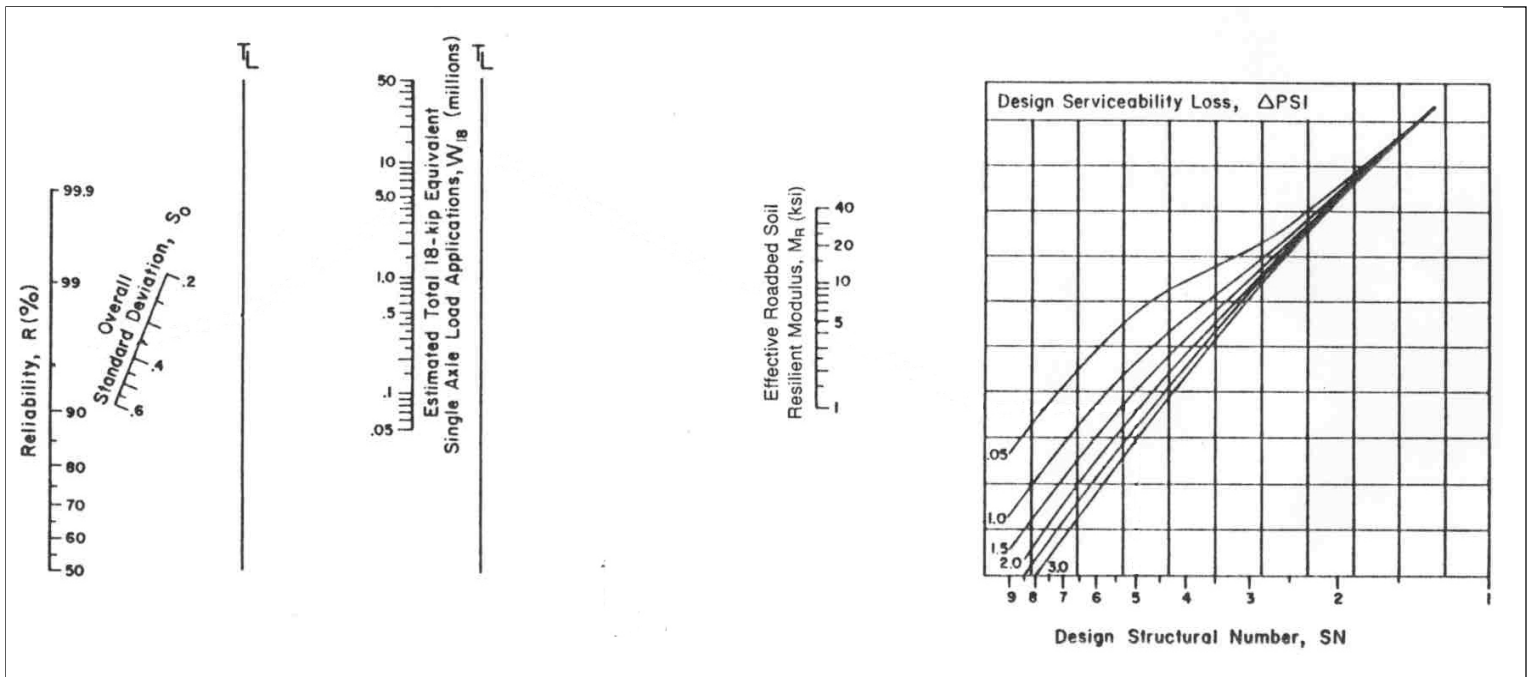

Table 3-6
STRENGTH COEFFICIENTS

Component	Limiting Criteria	Coefficient
Plant Mix Seal Coat		0.25
HMA	$R_t \geq 95$	0.44
	$R_t = 90 - 94$	0.40
	$R_t = 87 - 89$	0.35
	$R_t = 84 - 86$	0.30
	$R_t \leq 83$	0.25
Stone Mastic Asphalt		0.44
HMA other than Grading F		0.44
HMA Grading F		0.34
Hot In-Place Recycled Asphalt Pavement		0.36 - 0.44
Cold In-Place Recycled Asphalt Pavement		0.25
Road Mix Bituminous Pavement		0.20
Existing Bituminous Pavement		0.20 - 0.44
Plant Mix Bituminous Base	$R_t \geq 90$	0.34
	$R_t = 86 - 89$	0.30
	$R_t = 80 - 85$	0.25
	$R_t \leq 79$	0.22
Aggregate Base Course	$R_t \geq 84$	0.14
	$R_t = 78 - 83$	0.12
	$R_t = 70 - 77$	0.11
	$R_t \leq 69$	0.10
Emulsified Asphalt Treated Base Course	$R_t \geq 95$	0.23
	$R_t = 90 - 94$	0.20
	$R_t = 84 - 89$	0.15
	$R_t \leq 83$	0.12
Cement Treated Aggregate Base Course	7-day test ≥ 650 psi	0.23
	7-day test $= 400 - 649$ psi	0.20
	7-day test ≤ 399 psi	0.15
Hydrated Lime Treated Aggregate Base Course	"R" ≥ 84	0.14
	"R" $= 78 - 83$	0.12
Lime Treated Subgrade	7-day test ≥ 450 psi	0.15
	7-day test $= 350 - 424$ psi	0.14
	7-day test $= 276 - 349$ psi	0.13
	7-day test $= 200 - 274$ psi	0.12
	7-day test $= 126 - 199$ psi	0.11
Borrow Material		0.10 ¹
Notes:		
R_t is derived from following formula ($R_t = R + .05 C$) where R = R value, and C = a cohesion value either measured on a cohesiometer test apparatus, or in the case of CDOT, C is arbitrarily assigned.		
The minimum strength coefficient for the Base Course on highways having a current ADT volume of 750 or greater shall be 0.12		
¹ Used only to determine a value of strength for layers of soil and/or borrow materials which are located above the soil layer which the soil support value of the subgrade is determined.		

MINIMUM PAVEMENT COMPONENT THICKNESS

Even though it is possible to design pavement structures with thin layers when the supporting soils data indicate it has the supporting strength coefficients, good prudent engineering practices dictate that minimum thicknesses of each component should be used. The following table is minimum thickness values for the various components of a pavement structure.

Table 3-7
Recommended Minimum Pavement Structure Component Thickness

Component	Minimum Thickness - inches
Hot Mix Asphalt	2
HMA with occasional truck or heavy traffic	3
Stabilized Base (where used)	3
Base Course (where used)	4
Subbase (where used)	6

PAVEMENT DESIGN PROCEDURE (NOMOGRAPH METHOD)

1. Determine roadway classification, Reliability factor from the roadway classification from Table 3-3 and the Standard Normal Deviation S_o for the Reliability factor ($S_o=0.44$), Serviceability Index, SI and corresponding ESALs.
2. Determine the Resilient Modulus value (M_R) from either the subgrade CBR value or R-Value using equation 3-1 or 3-2 respectively.
3. Using the design nomograph, draw a straight line from the Reliability factor thru its standard deviate point to the 1st turning line T_L .
4. From the point of intersection of the 1st T_L line, draw a straight line thru the ESAL value and intersect the 2nd T_L line.
5. From the intersection of the 2nd T_L line, draw a straight line thru the M_R value to its intersection point with the Serviceability graph y-axes.
6. Draw a horizontal line to the SI line chosen for the design period.
7. From the point of intersection with the SI line, draw a vertical line down to the x-axes. The point of intersection will be the SN value for the pavement structure.
8. The SN value is then used to determine the various thickness of the layer of the pavement structure using equation 3-3.

Strength Coefficients for the various components of the pavement structure are given in Table 3-6. The component thickness selected cannot be less than the minimum specified in Table 3-7. However, the thickness of each layer can be varied.

Design Example

Problem: A roadway pavement structure needs to be determined from the site specific data which follows. The HMA pavement thickness as well as the base course and subbase course (if required) thicknesses has to be determined. The pavement section should have a 4 inch minimum Class 6 aggregate base course. If the Class 6 base course is over 6 inches, determine how much subbase course material would be required if the HMA mat is 4 inches and the Class 6 base course is 6 inches.

Site specific Data:

CBR of subgrade	5
Drainage	Good
Strength coefficient of HMA	0.44
Strength coefficient of Class 6 base	0.14
Strength coefficient of subbase	0.10
Soils classification	A-7-6 frost susceptible clays
Roadway classification	Principal Arterial
Number of lanes	4
Design life.....	20 years
Traffic volumes	
Cars and Pickups	100,000
Single Axle Trucks.....	250
Combination Trucks	500

solution:

1. Determine the roadway classification, Reliability Factor, Serviceability Index and corresponding ESALs

For a Principal Arterial roadway, Reliability R = 94%
 $S_o = 0.44$
 $SI = 3.0$

Current ADT. . . .	Cars and Pickups	100,000
	Single Axle Trucks	250
	Combination Trucks	500
	ADT=	<u>100,750</u>

ESALs are determine from CDOT's 5 step method

Steps 1&2 ~ Determine ADT at midpoint of design period (10 years) assuming a 4% growth factor per year.

Vehicle Type	Initial ADT	Project ADT @ midpoint (10yrs)
Cars and Pickups	100,000	148,025
Single Axle Trucks	250	370
Combination Trucks	500	740
Total ADT at midpoint (10 years)		149,135

$$\text{Growth factor} = 1.04^{10} = 1.4802443$$

Step 3 - Determine 18K EDLA for entire roadway

Vehicle Type	Midpoint ADT	18K Equivalency Factor ¹	EDLA
Cars & Pickups	148,025	0.0030	444
Single Axle Trucks	370	0.2490	92
Combination Trucks	740	1.0870	804
		18K EDLA 1,340	
¹ From Table 2-7			

Step 4 - Adjust 18K EDLA for 4 lanes~adjustment factor 0.45 is from Table 2-8 for two lanes in one direction.

$$1,340 \times 0.45 = 603$$

Step 5 - Convert 18K EDLA to 18K ESALs

$$\text{ESALs} = (603 \text{ EDLA})(365 \text{ days/year})(20 \text{ years}) = 4,401,900 \text{ ESALs}$$

2. Determine Resilient Modulus M_R for the subgrade soil

$$M_R = 1500 \times \text{CBR} \quad \text{Eq. 3-1}$$

$$M_R = 1500 \times 5 = 7500 \text{ psi}$$

3. Using the Flexible Pavement Design Nomograph (Figure 3-1) and steps 3 thru 8 in the pavement design procedure, determine SN.

$$\text{SN} = 4.05 \quad \text{from the design nomograph (see figure 3-2, pg 3-13)}$$

4. Alternate pavement structural section determination.

Alternate pavement structural sections are determined from equation 3-3:

$$\text{SN} = a_1 D_1 + a_2 D_2 m_2 + a_3 D_3 m_3 + \dots$$

Where: a_1 = strength coefficient for the various surfacing materials
 a_2, a_3, a_n = strength coefficient for additional structural components, i.e. base course, subbase course and any other subgrade treatment from Table 3-6.

D_1 = thickness of the various surfacing materials corresponding to the Strength coefficient.

D_2, D_3, D_n = thickness of the additional structural components corresponding to their strength coefficients.

m_2, m_3, m_n = drainage coefficient for the various structural layers from Table 3-1.
Solve for SN in equation 3-3 to determine the amount of class 6 base required for a 4-inch HMA surface:

$$4.05 = (4" \text{ HMA})(0.44) + (x" \text{ class 6})(0.14)(1.30) \qquad x" \text{ class 6} = \frac{4.05 - (4" \text{ HMA})(0.44)}{(0.14)(1.30)} = 13" \text{ class 6}$$

The required HMA and Class 6 ABC would be four inches of HMA plus thirteen inches of Class 6 ABC for a total pavement thickness of seventeen inches.

Since the required Class 6 thickness was greater than six inches, you need to determine an alternate section with four inches of HMA and six inches of Class 6 ABC and an unknown thickness of subbase. Substituting those values into equation 3-3:

$$4.05 = (4" \text{ HMA})(0.44) + (6" \text{ class 6})(0.14)(1.30) + (x" \text{ subbase})(0.10)(1.30)$$

$$x" \text{ subbase} = \frac{4.05 - (4" \text{ HMA})(0.44) - (6" \text{ class 6})(0.14)(1.30)}{(0.10)(1.30)} = 10" \text{ subbase}$$

The required HMA, Class 6 ABC and subbase would be four inches of HMA plus six inches of class 6 ABC and ten inches of subbase for a total pavement thickness of twenty inches.

- Notes:
- Since the subgrade was a fine-grain clay, a separation fabric between the subgrade and subbase should be recommended.
 - The binder for S Grading HMA should be PG 58-34.
 - Superpave S or SX would be chosen by the contractor.
 - Based on 4.402 million ESALs, the design gyrations for the job mix formula would be $N_{\text{Design}} = 100$ gyrations (from Table 2-1).

The decision as to what alternate Hot Mix Asphalt pavement section to use should be made based on several factors:

- Available material resources.
- Available contractor capabilities in place.
- Cost of each component material including excavation and earthwork quantities.
- Life cycle cost analysis which should include future maintenance costs.

Metropolitan Government Pavement Engineers Council (MGPEC) specification and design procedures in their manual, for the design and construction of HMA pavement, are being used by several of the local entities in the Front Range.

AASHTO Guide for Design of Pavement Structure is another valuable resource on the subject. These publications are available from the respective organizations.

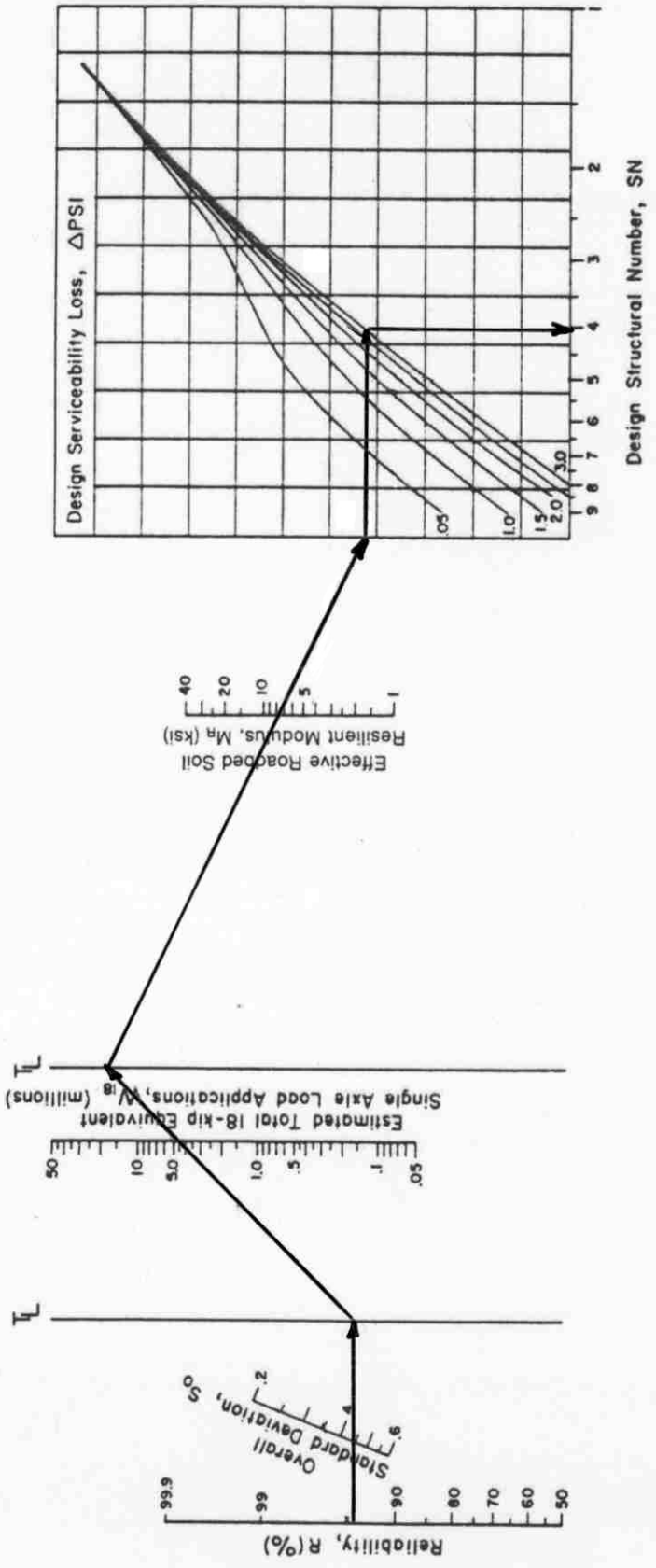

CHAPTER FOUR

SUBGRADE

AND

AGGREGATE BASE COURSE

STABILIZATION

CHAPTER FOUR

SUBGRADE AND AGGREGATE BASE COURSE STABILIZATION

METHODS OF SUBGRADE STABILIZATION

In areas of very poor subgrade capacity, the cost of increasing the pavement sections above the subgrade can be significant and sometimes prohibitive. Increasing the support capacity of the subgrade soils and/or increasing the strength within the pavement section through the use of stabilization are often beneficial.

Common methods of stabilizing soils and the aggregate base course within the pavement section are as follows:

- Lime Stabilization
- Cement and Fly ash Stabilization
- Asphalt Emulsion Stabilization
- Chemical Stabilization
- Geotextiles

A lime and fly ash combination has proven to be very effective in treating soils that have variable characteristics such as pockets of clay, pockets of sand, and pockets of sandy clay.

Geosynthetic stabilization or strengthening of the subgrade through the use of geotextiles is a separate chapter in this Guide. Additional information concerning the use of geosynthetics can be obtained from Tensar Earth Technologies, Inc. (TET). They have available a software program for designing flexible pavements using geotextiles for subgrade strengthening and stabilization. The software is available by contacting TET.

Special chemical stabilization, other than the chemical benefits of cement, lime, and lime/fly ash is not covered in the design guide.

LIME STABILIZATION

For subgrade soils, which exhibit plasticity indexes of ten, or above, lime stabilization is an option. **Lime is used only in plastic soils where expansion potential combined with a lack of stability is a problem.**

Sulfate Limits

Unless special procedures are used to address the sulfate growth potential in subgrade soils, lime stabilization should not be used where measurable sulfates are **greater than 0.8 percent (0.8%)**. With sulfate levels up to 3,000 parts per million (ppm) (0.3%) there is little reason to be concerned about sulfates. At this level of sulfate concentrations normal lime stabilization procedures can be followed.

With sulfate levels between 3,000 and 8,000 ppm, soils can often be successfully stabilized using lime. The practice most commonly used is to mix about half of the required lime into the soil in one application and allow it to react with the sulfates for seven to fourteen days. During this time it is important that the soil be kept wet to insure sufficient components for the formation of ettringite crystals. At the end of the conditioning period, the remaining lime can be added and incorporated into the modified subgrade, mixed and compacted

using common construction procedures for finishing the subgrade. Whenever sulfates are present, it is particularly important that the work be supervised by a qualified geotechnical engineer.

Benefits

The benefits of lime include an increase in unconfined strength, a reduction of plasticity, a reduction in swell potential, and a reduction in soil permeability (water migration).

Soil Makeup

Lime stabilization is generally applied to soil materials that do not contain boulders, cobbles or high amounts of large size gravel that prevents the dispersion of the lime using conventional mixing equipment.

Lime stabilization requires some degree of stable substrate to obtain compaction following the lime mixing. Accordingly, severely unstable subgrade material will require stabilization through the use of pit-run or other materials below the lime stabilized subgrade. Lime stabilization requires the use of heavy equipment during the lime mixing operation which will also require the subgrade below the lime stabilization layer not be fluid or highly unstable. It is sometimes possible to bridge unstable subgrade by increasing the depth of treatment by an additional six to twelve inches. In areas where the subgrade is severely unstable, geogrids, geotextiles, lime injection, or other means of stabilization should be considered.

Design

If lime stabilization is chosen to be the option, a qualified laboratory should perform a lime/soil mix design, which establishes the unconfined compressive strength of soil/lime mixtures. The design should include several composite points, which evaluate the unconfined compressive strength of the lime mixture at various lime contents (based upon percent of dry soil weight). The composite points should be performed until the pH value of the soil reaches 12.4, which is the target minimum pH value. When possible, the subcontractor should be consulted to determine the method of lime stabilization (dry or slurry application). The mix design should include any necessary mellowing periods, usually forty eight hours; the number of required mixing periods, and the density of the compacted specimens. The mix design specimens should be prepared in accordance with the following test procedures:

- ASTM C 977-95 Standard Specifications for Quicklime and Hydrated Lime for Soil Stabilization
- ASTM D 558 Moisture Density Relations of Soil-Cement Mixtures
- ASTM D 1632 Making and Curing Soil Cement Compression and Flexure Test Specimens in the Laboratory
- ASTM D 1633 Compressive Strength of Molded Soil-Cement Cylinders

Lime stabilization will provide a structural coefficient, which will reduce the amount of materials proposed for the pavement section without lime stabilization. The structural coefficients which can be applied for lime stabilization are variable based upon compressive strength. The structural coefficients for various compressive strengths of the modified subgrade soils are shown in Table 4-1. The structural coefficients shown in Table 4-1 can be used in the Structural Number (SN) equation (3-3) when determining the thickness of the various layers of the pavement structure.

Table 4-1
Structural Coefficients for Lime Stabilized Soils, a_i

Compressive Strength	Coefficient
160 psi	.11
200 psi	.12
300 psi	.13
400 psi	.14
500 psi	.15

If Hot Mix Asphalt (HMA) is not to be placed immediately after lime stabilization, the final construction specifications should include the requirement to maintain a moist layer for at least seven days after compaction through the use of frequent watering, or an applied moisture barrier.

CEMENT STABILIZATION

Precautions

For subgrade soils, which exhibit plasticity indexes of 10 or less, cement stabilization is an option. Cement is used in low plasticity or non-plastic soils where stability due to soil characteristics or water migration is a problem or when a cement stabilization layer will provide a more cost effective pavement layer. Stabilization of aggregate base course as a pavement layer is commonly referred to as Cement Treated Base Course (CTB).

In effect, soil cement stabilization is very similar to lime stabilization. Cement is susceptible to measured sulfates and alkalis, but a combination of cement and fly ash will, in most cases, provide the ability to stabilize the soil with no detrimental effects from sulfates and alkali.

Due to permanent hydration and cementation, soil cement and CTB have more severe time constraints with which to work the material. Subgrade and bases stabilized with cement can also cause transverse cracking resulting in reflective cracking at the pavement surface.

Construction

Soil cement stabilization can be performed in-place with the use of a pulverizer or recycler machine, but is also commonly mixed with a pug-mill and less commonly with a drum mixing plant. The use of pug-mill and drum mixing plants is an option due to the lower plasticity of cement stabilized soils and the ability to mix the soil more efficiently with lower efforts.

Soil cement and CTB, like lime, require a compactive effort to construct the layer. Accordingly, like lime, the severity of subgrade stability will directly relate to the ability to construct the layer. Some stabilization beneath the layer may be necessary to construct soil cement or CTB. The stabilization of the soil beneath the subgrade layer may not necessarily be a permanent application, but one that provides stability for the construction of the soil cement or CTB only.

Benefits

The benefits of cement-stabilized soil and CTB include an **almost unlimited** compressive strength up to approximately 800 pounds per square inch.

Design

If soil cement stabilization or CTB is chosen to be the option, a qualified laboratory should perform a mix design, which establishes the unconfined compressive strength of soil cement or CTB mixtures. The design should include several composite points, which evaluate the unconfined compressive strength of the cement mixture at various cement contents (based upon percent of dry soil weight). The mix design specimens should be prepared in accordance with the same test procedures as for lime stabilization (i.e. ASTM D 558, D 1632, D 1633). The report should include the as-tested density of the test specimens.

Cement stabilization and CTB will provide a structural coefficient that will reduce the amount of materials previously required for the pavement structural section without stabilization. The structural coefficients which can be applied for cement stabilization and CTB are based upon compressive strength of the modified layer. The structural coefficients for various compressive strengths of the modified subgrade soils for soil cement and cement treated base are shown in Table 4-2. Similarly, the structural coefficients shown in Table 4-2 can be used in the Structural Number equation (3-3).

Table 4-2
Structural Coefficients for Cement Stabilized Soils or CTB, a_i

Soil Cement Compressive Strength psi	Coefficient	CTB Compressive Strength psi	Coefficient
200	.17	200	.22
300	.18	300	.23
400	.19	400	.24
500	.20	500	.25
600	.21	600	.26
700	.22	700	.27
800	.23	800	.28

EMULSIFIED ASPHALT STABILIZATION

Design

Soil stabilization with an asphalt emulsion is a viable alternative when the soils to be stabilized are sandy and do not have an excessive amount of material finer than the #200 sieve. The asphalt emulsion works well on sandy soils in that it will increase load bearing capacity, firmness, and resistance to displacement. **A Basic Asphalt Emulsions Manual (MS-19)** compiled by the Asphalt Institute provides guidelines for blending and some general specifications for sand emulsion mixes. The following Table 4-3, Gradations for Sand-Emulsion Mixes, is from the **MS-19** manual.

Table 4-3 Gradations for Sand-Emulsion Mixes

Sieve Size	Total Percent Passing		
	Poorly-Graded	Well-Graded	Silty Sands
½"	100	100	100
#4	75-100	75-100	75-100
#50	-	15-30	-
#100	-	-	15-65
#200	0-12	5-12	12-20
Sand Equivalent, percent	30 min.	30 min.	30 min.
Plasticity Index	NP	NP	NP

The emulsified asphalt content of the mixes shown in Table 4-3 normally varies between 6% and 15%. Emulsified asphalt Types SS-1, SS-1h, CSS-1 or CSS-1h may be used along with a laboratory-determined amount of mixing water added to the sand.

The stabilization operation can be a simple process where the asphalt emulsion is mixed with the sandy soil in-place by a traveling mixer or with a blade. When appropriate, imported aggregate and/or milled asphalt can be added to strengthen the stabilized material.

Proper mixing and coating for stabilization depends on the proper amount of pre-wetting of the sandy material before applying the emulsion. The amount of water, type, and amount of emulsion, whether or not to add aggregate, and if so how much should be determined by a qualified laboratory.

Precautions

If it rains before the mixture is compacted and cured, traffic should be kept off until it cures and necessary compaction or re-compaction can be accomplished. Use only as much mixing water as is necessary to disperse the asphalt emulsion. Over mixing may cause the emulsion to strip from the sand particles or break prematurely. For faster curing, place the emulsion sand mixture in several thin layers rather than a single thick layer. For best results placement should be at or above seventy degrees Fahrenheit (70°F). Do not seal emulsion sand mix surfaces too soon. Entrapped mixing water and distillates may create problems.

Placing

After mixing the emulsion into the sand no delay should take place before final shaping to grade. After the breaking of the emulsion has occurred and curing has begun, the mixture may become very difficult to spread without tearing. In order to obtain a smooth finished surface, the emulsion sand mixture must remain workable throughout the spreading operation. In some cases, the addition of about one to two percent Portland cement may accelerate development of initial strengths.

Compaction

Just as for hot mix asphalt, the importance of good compaction in emulsion-sand mix stabilization is very important. Emulsion-sand mixes respond to conventional compaction procedures. Pneumatic tired and static steel wheel rollers are desirable for thickness of up to three inches (3"). Whereas vibratory rollers produce better results for thicker lifts. A minimum field compaction of ninety five percent (95%) of the laboratory density is usually specified.

OVER-EXCAVATION METHOD

Expansive soils should be treated to reduce their expansive properties with some type of stabilization or they can be removed altogether. Over-excavating and removing the expansive soil (dry dense unweathered shales and dry dense clays) and backfilling with an impermeable soil at ninety five percent of maximum dry density at or above optimum moisture, in accordance ASTM D 698 or D 1557, can be cost effective.

The over excavation should carry through the cut area and transitions from cut to fill area until the depth of fill is approximately equal to the depth of treatment. Table 4-4 can be used as a guide to determine the depth of over excavation for expansive soils. Projects on Interstate and National Highway System roadways will require treatment of expansive soils.

Table 4-4
Suggest Depth of Over-Excavation for Expansive Soils

Plasticity Index	Depth of Over-Excavation Below Normal Subgrade Elevation
10-20	2 feet
20-30	3 feet
30-40	4 feet
40-50	5 feet
More than 50	6 feet

Soils with a plasticity index of more than fifty should be placed in the bottom of fills of less than fifty feet in height, or wasted. The backfill soil should be uniform and lenses or pockets of very high swelling soil should be removed and replaced with the predominant type of soil that has a plasticity index of less than fifty. Drainage ditches must be below the subgrade level in cut areas and must have enough grade to allow rapid runoff of surface water.

The Colorado Department of Transportation's ***Pavement Design Manual*** and the Metropolitan Government Pavement Engineers Council's ***Pavement Design Standards and Construction Specifications*** have criteria and specifications that cover the stabilization of expansive soils and subgrade. Their criteria has been very successful in dealing with expansive soil problems in pavement structures.

CHAPTER FIVE

CONSTRUCTION

OF

HOT MIX ASPHALT PAVEMENTS

CHAPTER FIVE

CONSTRUCTION OF HOT MIX ASPHALT PAVEMENTS

INTRODUCTION

Each year, billions of dollars are spent on hot mix asphalt (HMA) construction projects in the United States. Achieving good performance of these pavements does not just happen, but is the result of many hours of effort and project management by pavement design and construction professionals. Each phase of a project, from the drawing board to the laboratory to the field, contains important steps and procedures that must be followed to ensure a long lasting, well performing pavement. Successful projects are achieved thru good project management.

The primary purpose of HMA construction project management is to foresee and predict as many of the dangers and problems as possible and to plan and control activities so the project may be completed successfully in spite of the risks. This process starts before any resources are committed, and must continue until the work is finished. The objective is for the final result to satisfy the project owner within the promised time period and without using more dollars and other resources than those originally established by a contract agreement.

The 21st Century ushers in a new relationship with the agency/contractor in the HMA construction industry. The new relationship is based upon an increasing recognition of the importance of quality during 1990's. As a result, the Total Quality Management (TQM) concept is being adopted as the key to the HMA industry's ability to compete in today's environment. Partnering, training programs, certification requirements, etc. are integral parts of the overall TQM concept.



the

Planning and control must be exercised over the activities and resources involved in the HMA construction project. This can only be accomplished through effective communication. The communication process requires an understanding of the project documents by both the owner's representatives and the contractor's personnel. They should have a knowledge and a thorough understanding of construction methods and techniques and a knowledge of the equipment from the HMA production facilities to the compaction of the HMA pavement. With knowledge and understanding of these areas the two most important characteristics in the HMA placement process, smoothness and air voids (related to density) can be achieved. Smoothness of the pavement is the most important characteristic for the driving public or agency satisfaction. The driving public is happy as long as the pavement remains smooth and has good traction.

This chapter discusses the processes involved in the construction of HMA pavements and the equipment used in the process.

CONSTRUCTION EQUIPMENT

It is the responsibility of the contractor to provide equipment that will produce results in compliance with the plans and specifications of the contract. The equipment should be in repair and top operating condition in order to achieve the results the owner has specified. This section contains information on the basic equipment, shown in the list below, used to produce and construct HMA pavements.

- Asphalt Production Facility
 - Hauling / Trucking
 - Placement
 - Compaction

ASPHALT PRODUCTION FACILITIES

Plant Types

An asphalt plant is an assembly of mechanical and electronic equipment where aggregates are blended, dried, heated, and mixed with asphalt binder to produce hot mix asphalt (HMA) meeting specified requirements. Asphalt plants vary in mixing capacity, and may be stationary (located at a permanent location) or portable (moved from job to job). In general, every plant can be categorized as either a batch plant (Figure 5-1) or a drum mix plant (Figure 5-2).

Regardless of the type of hot mix plant, the basic purpose is the same - to produce HMA containing the specified proportions of asphalt and aggregate. Both batch plants and drum mix plants are designed to accomplish this purpose.

Figure 5-1 Major Components of a Batch Plant

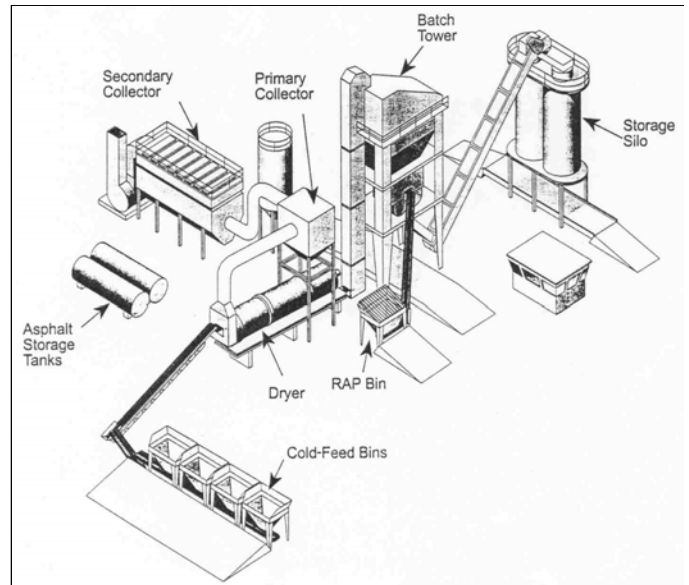
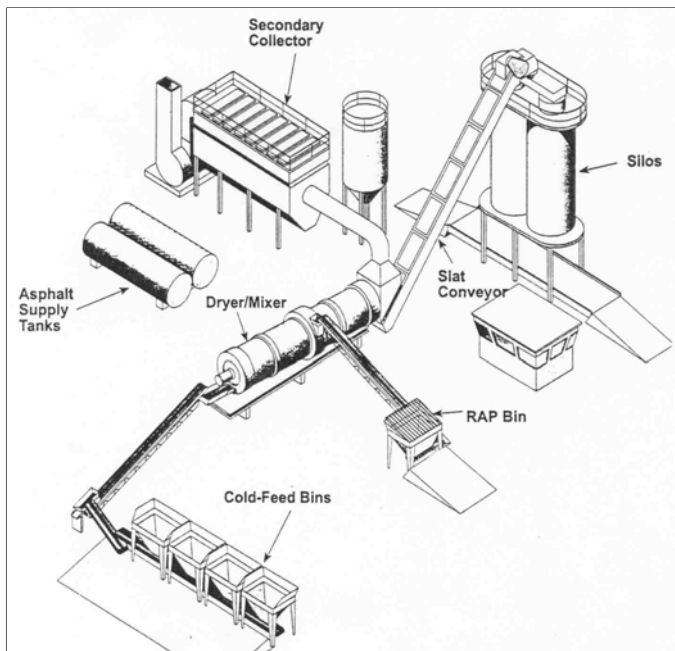

Figure 5-2 Major Components of a Drum Plant



The basic operations involved in producing HMA are the same regardless of the plant type. These operations include:

1. Proper storage and handling of HMA component materials at the mixing facility
2. Accurate proportioning and feeding of the cold aggregate to the dryer.
3. Effective drying and heating of the aggregate to the proper temperature.
4. Efficient control and collection of the dust from the dryer.
5. Proper proportioning, feeding and mixing of asphalt with heated aggregate.
6. Correct storage, dispensing, weighing, and handling of finished HMA.

There are many styles and types of HMA production equipment that can effectively accomplish these steps. The procedures listed above are common to all types of mixing facilities. The basic difference between batch, drum mix plants are in how they mix asphalt binder, and aggregate after it has been dried and heated (Step 5). Batch plants screen and separate the aggregate into separate bins after it has been dried, and then recombine the aggregate and mix it with the asphalt, one batch at a time in a separate mixer. Drum mix plants dry the aggregate and blend it with asphalt in a continuous process within the dryer drum; hence the name drum mixer.

Common to all HMA facilities is the importance of uniformity and balance of plant operations and materials. Uniformity ensures that the HMA is consistently produced to meet job specifications. It encompasses uniformity of materials, uniformity of material proportioning, and continuous, uniform operation of plant components. Changes in material characteristics or proportions and intermittent stops and starts in plant operations make it extremely difficult to produce quality HMA.



Balance involves careful coordination of the elements of production and placement. Balancing material quantities to plant production and balancing plant production and pavement placing operations guarantee a continuous, uniform production and placement effort.

The HMA production plant should have the means to obtain the required percentage of asphalt in the mix within the tolerance specified. The correct percentage of asphalt binder contained in the mix can be measured and evaluated by weighing, metering, or measuring the asphalt volumetrically.

The heating and drying system in the plant should be capable of heating the aggregate to the proper mixing temperature. The asphalt binder is heated in the storage units and if not at the same temperature of the aggregate will heat to the same temperature as the aggregate as soon as it comes in contact with it in the mixer. Table 5-1 shows the typical temperature range of the asphalt binder for storage and mixing for the various grades of PG graded binders. Also shown is the minimum temperature that the mixture should be delivered to the job site for ease of placement and proper compaction to take place.

Table 5-1 Typical Binder Storage, HMA Mixing and Delivery Temperatures

Binder Grade	Storage Temperature (°F)	Mixing Temperature (°F)	Minimum Mix Delivery Temperature ² (°F)
PG 58-22	280 - 305	260 - 310	235 °F
PG 58-28	280 - 305	260 - 310	235 °F
PG 58-34	280 - 305	260 - 310	235 °F
PG 64-22	285 - 315	265 - 320	280 °F
PG 64-28	285 - 315	265 - 320	280 °F
PG 70-28	295 - 320	275 - 325	280 °F
PG 76-28	310 - 325	280 - 330	280 °F

¹The maximum mix discharge temperature shall not exceed the minimum discharge temperature by more than 17 °C (30 °F) ²Delivered mix temperature shall be measured behind the paver screed.
Source: Asphalt Pavement Environmental Council Best Practices

Liquid Asphalt Storage

Asphalt storage tanks store the various grades of liquid asphalt that will be used at the plant for different mix designs. There should be a tank for each of the different grades of asphalt with sufficient capacity to maintain a uniform operation. They should be calibrated so that the amount of material remaining in the tank can be determined at any time. The storage tanks should have a device for the controlled heating of the

liquid asphalt to the temperature requirements as specified for the grade of asphalt being stored. Heating should be accomplished so that no flame will come in contact with the tank. The most common heating system is a hot oil system that circulates heat transfer oil through an enclosed coil circulating system within the storage tank. The circulating system should be large enough to ensure the temperature of the asphalt is maintained within the specified range during the entire operating period. Some storage tanks have internal circulating system for modified asphalt to keep the material from separating. Any storage tank with an internal circulating system for the asphalt should not have a free discharge end of the circulating system. The circulating system discharge should be kept below the surface of the asphalt in the tank to prevent foaming. Either a hot oil, steam jacketing or an insulation system should maintain the specified temperature of asphalt in pipelines, meters, buckets, spray bars, flow lines, and other containers that is required in the mixing process.

As stated earlier, it is imperative to keep the liquid asphalt at the proper temperature. The same asphalt at different temperatures has different specific gravities. In a drum mix plant the asphalt feed is determined by a volumetric pump controlled by the plant computer that calculates its rate based on the specific gravity of the liquid asphalt input by the operator.

Any material (especially modified asphalt) remaining in a storage tank should be purged before adding a different grade of asphalt.

The heating system for the asphalt storage also provides heating for the surge silos and the asphalt piping system in the plant. It is imperative to keep the asphalt and the HMA at the proper temperatures in order that the pumping system operates properly and no stoppage occurs. A thermometer ranging from 200° F to 400° F should be placed in the asphalt feed line or tank to monitor the actual temperature of the asphalt.

Aggregate Cold Feed

The aggregate cold feed system is the first major component of the HMA plant. It receives cold (unheated) aggregate from storage and moves it to the dryer. It is again worth noting that none of the plant's equipment or control automation can detect or correct inconsistencies in gradation or aggregate quality. Cold feeds can only meter and proportion the supplied aggregate to a given accuracy and consistency. Therefore, quality control of the aggregate production is required to ensure delivery of a uniform, consistent aggregate quality and gradation.

The aggregate cold feed system generally consists of a series of cold feed bins that are filled, or charged, by front end loaders which obtain the aggregates from stockpiles. In some cases, large stockpiles separated by bulkheads are built over tunnels, or where belts transport the material, or large storage bunkers or bins are used.

Aggregate from each stockpile should be placed into an individual cold bin. The bins should be kept full enough to ensure a uniform flow through the feeder. Uniform cold feeding is vital to ensure continuous, uniform operations throughout the plant. When cold bins are charged, care should be exercised to minimize segregation and degradation of the aggregate. Cold feed bins should not be overcharged (heaped) to the point where materials can overflow from one bin to another.

Gates located at the bottom of the bins feed controlled amounts of the different aggregates onto the conveyor carrying them to the dryer. Feeder controls regulate the amount of aggregate flowing from each bin, providing a continuous, uniform flow of a properly graded aggregate blend to the plant.

Because a uniform flow of properly sized aggregates is so important to consistent HMA production, a check should be made before and during production to be certain that the feeder system is functioning properly. The following conditions are important for maintaining uniform flow and consistency:

- Correct sizes of aggregates in stockpiles and cold bins, No segregation of aggregates
- No intermixing of aggregate stocks
- Accurately calibrated, set and secured feeder gates
- No obstructions in feeder gates or in cold bins
- Correct speed control settings

Proper aggregate temperature is essential to mix temperature control. The asphalt added to the aggregate during mixing assumes the aggregates temperature almost immediately. Excessively heated aggregate during mixing can cause accelerated hardening of the asphalt during its life. Under-heated aggregate is difficult to coat thoroughly and the resulting mix is difficult to place on the roadway.

Additive System

The additive storage system is used for storing and injection of mineral filler and or anti-stripping agents into the HMA mixture. Mineral filler is a finely divided mineral product at least 70 percent of which will pass a 0.075mm (No.200) sieve. Pulverized limestone is the most commonly manufactured filler, although other stone dust, hydrated lime, Portland cement, and certain natural deposits of finely divided mineral matter are also used.

Storage and Handling of mineral filler is subject to tight control. Mineral filler is subject to caking or hardening when exposed to moisture. Therefore, separate storage should be provided to protect from dampness. In plant operations where mineral filler usage is high, a bulk storage silo is often used. Such a system can have either a pneumatic or mechanical device for feeding filler into the plant. In pneumatic systems, mineral filler is entrained in an air stream and is handled as a fluid, offering accurate control and eliminating plugging.

The pneumatic system generally consists of a receiving hopper, screw conveyor, dust-tight elevator, and silo. The hopper and elevator load the silo from which mineral filler is metered into the plant. The silo may also be loaded directly from suitably equipped filler transport trucks. The mineral filler is normally introduced into the mix in the weigh hopper of the batch plant. In some plants a separate weighing system may be provided. In a drum plant the mineral filler is introduced pneumatically through a pipe located where the asphalt is introduced. A bag-feeding, mineral filler system may also be used. This system consists of a ground mounted feeder, dust-tight elevator, surge hopper, vane feeder or screw conveyor, and an overflow chute.

In both bulk and bag systems, final metering of the filler into the mix is accomplished through a variable speed vane or screw feeder, or belt feeder depending on the material to be handled and the capacity required. In each case, the mineral filler feed mechanism is interlocked with the aggregate and asphalt feed mechanisms to ensure uniform proportioning.

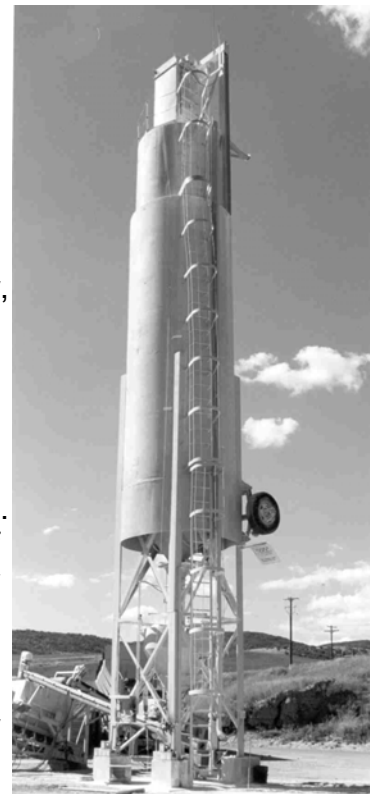

Mineral filler handling also involves a plant's dust collection system. Dust collectors are designed to capture fines escaping from the aggregate mixture and return them to the plant for incorporation into the mix.

Hydrated lime is also used as an anti-stripping agent, for insuring the adhesion of the asphalt binder to the aggregate, as well as a mineral filler. A pneumatic handling system is generally used when it is incorporated dry into the mix. When used as an anti-stripping agent, hydrated lime can be added to the moist aggregate or made into a slurry and then thoroughly mixed in an approved pugmill. Generally the additive-aggregate mixture is fed directly into the plant after mixing. However, a lime slurry mixture may be stockpiled before introduction into the plant for mixing.

When the mineral filler is added to the mix, its proportioning must be exact. Consequently, the flow of filler into the plant must be carefully controlled and frequently checked. The percentage of filler entering the mixture can be calculated by simply measuring the amount of filler consumed by the plant during production of a given amount of HMA.

Emission Control System

The production plant will have an emission control system consisting of a scrubber, dust collector, a mixer cover, and whatever additional housing necessary to ensure proper dust control. The air flowing through the dryer carries with it exhaust gases and a small amount of the aggregate dust particles. Because some fine material becomes airborne, emission control equipment must be present to capture this dust before it is discharged into the atmosphere. These emissions must not exceed the various state and federal air pollution limits.

The emission control system in most HMA facilities generally consists of primary and secondary dust collectors. The primary collector is a cyclone type collector while the secondary collector is usually a bag house or wet scrubber. The dust collectors are situated at the end of the dryer and filter the air that enters at the burner and exits at the exhaust fan. The primary collector is to collect and remove the larger dust particles contained in the exhaust gas stream. The secondary collector is to filter out the finest dust particles.

When the plant stack is emitting a brownish cloud, the emission system should be checked. The only visual emissions from the plant stack should be a stream of white steam from the drying of the aggregate.

HMA Storage

To prevent plant shutdowns due to temporary interruptions of paving operations or shortages of haul trucks, most asphalt plants are equipped with *storage silos* or *surge bins* for temporary storage of HMA. Newly made HMA is deposited by conveyor or hot elevator into the top of the silo or bin and is discharged into trucks from the bottom. Insulated storage silos can store HMA up to 24 hours with no significant loss of heat or quality. Non-insulated storage structures, generally called surge bins, are usually smaller and can store hot mix only for short periods of time.

Storage silos work well if certain precautions are followed, but they can cause segregation of the mix if not used properly. A batcher or gob hopper should be used in conjunction with the silo to keep segregation to a minimum. The mix is conveyed into a batcher or gob hopper at the top of the silo. Once a predetermined amount of HMA is deposited in the batcher, it releases the mix in to the silo in a single mass.

Plant Safety

Adequate and safe access should be provided to the various component of the production facilities. Stairways to the mixer platform and guarded ladders to other units of the facility should be provided. Gears,

pulleys, chains, sprockets, and other dangerous moving parts should be well guarded and protected. A platform for sampling and inspection of the mix should be located near the facility.

Weighting and Hauling

HMA is hauled to the paving sites in various types of trucks. Hauling trucks vary by size and type, but uniformity of equipment is very desirable in any asphalt paving operation. The trucks should be inspected carefully before use. For accurate material control, truckloads of HMA must be weighed at the plant.

The quantity of HMA delivered from plant to paving site can be determined by either of two methods: (1) weighing loaded trucks on scales, or (2) using a plant's automatic recording system (in the case of fully automated plants). When truck scales are used, they must be of the type that directly indicates the total weight of the truck. They must be horizontal and of sufficient size to weigh all of a truck's axles at one time.

The accuracy of truck scales must be checked periodically. During a normal day's operation, the scale should be checked frequently to make sure that it is in balance. Mud or other foreign matter left on the platform by the trucks can throw the scale out of balance.

In addition to periodic checks of the scale and platform, each truck must be randomly tarred (weighed when empty). A permanent record of the tare weight must be maintained in the scale house and, when required, in the truck. Electronic automated printout weigh tickets are now accepted by a number of states and other agencies. These tickets usually will contain the gross, tare and net weights of the HMA being delivered to the job site.

Haul trucks used in hauling the HMA to the job site should be clean and smooth to prevent excessive sticking and also have tight bodies to prevent material loss. A satisfactory and environmentally safe release agent should be used to ensure the easy discharge of the HMA material at the paver. Diesel should not be used as a release agent for it breaks down the HMA and has a negative effect on the environment. A listing of release agents can be found on the CDOT web site www.dot.state.co.us.

The haul truck beds should be equipped with suitable covers to protect the mixture in transit during unfavorable weather conditions and to help maintain the mix temperature for the proper placement of the HMA. There is an indication that some coarse-graded Superpave designed mixtures tend to cool more quickly than conventional HMA. Simply increasing the mix temperature to allow for the extra cooling is more expensive, results in more hardening of the asphalt binder, and results in more emissions from the plant. Using insulated trucks and placing a tarp in good condition over the loaded HMA will minimize temperature loss. Taking steps to ensure that the aggregate is thoroughly dried will also help reduce the temperature loss.

Most haul trucks are either a tandem dump truck or a semi-trailer end dump. They either dump their load of HMA directly into the paver or into a shuttle buggy that re-mixes the HMA to minimize segregation. Some shuttle buggies are capable of picking up the HMA mixture directly from the prepared road bed. In that case, the hauling equipment can be a belly dump type trailer that dumps the HMA in a windrow directly in line with the paving operation.

During the paving operation, an adequate number of haul trucks should be available to keep a steady supply of HMA to the paver to provide for a continuous paving operation, which ensures a smoother mat with little to no segregation problems. Larger capacity hauling equipment such as the semi-trailers will give a better finished mat because of less stoppage during the placement operation. Truck drivers need to be capable of backing up to the paver as well as driving a straight line while emptying their load of HMA into the paver equipment.

Preventing Segregation

Figure 5-4 Multiple Drop Loading Sequence

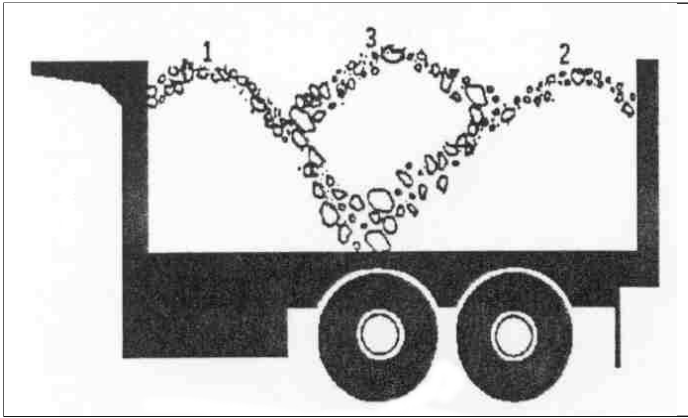

Just as it is important to deliver mix into the silo in a mass, it is also important to deposit the HMA in a mass into the haul truck. The gates on the bottom of the cone of the silo should be opened and closed quickly. It is also necessary for the gates to open completely so that the flow of mix is unrestricted. There is only one reason to cut off the flow of mix into the vehicle once that delivery has started and that is to divide the delivery of the mix into different sections of the truck.

If the HMA is placed in the haul vehicle in one drop from the silo, segregation of the larger aggregate particles can occur. If the HMA is deposited into the center of the truck bed, the material will build up into a conical-shaped pile, as illustrated in Figure 5-3. Because the growth of the pile will be restricted by the sides of the truck, the bigger aggregate particles will roll toward the front and the tailgate of the truck bed. These pieces accumulate at both ends of the load and are then delivered into the hopper on the paver from the truck bed. The pockets of coarse material then appear in the mat behind the paver at the end of the truckload of mix. In reality, some of the large aggregate pieces come from the end of one truckload and also from the beginning of the next truckload of mix. This is called **truck end segregation**.

Figure 5-3 Single Drop Loading Sequence

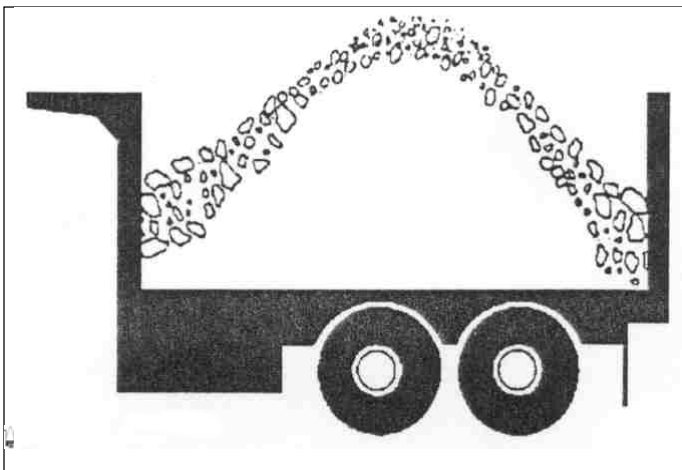

Truck end segregation problems can be minimized by dividing the delivery of the asphalt mix from the silo into multiple drops, each delivered to a different section of the truck bed. The first drop of mix should be into the front portion of the bed and the second drop should be near the tailgate. The remaining mix should be delivered in evenly divided drops into the rest of the length of the truck bed. **Use caution when loading continuously.** This operation may cause the coarse aggregate particles to collect at the tailgate of the truck and increase the amount of segregation that may occur. If this type of problem occurs from loading continuously, then the

Superpave designed mixtures containing some types of modified binders will have a greater tendency to stick to the beds and be more difficult to remove from the trucks. Segregation of Superpave designed mixtures can be a problem, but is somewhat less likely to occur than with conventional HMA. Trucks should be properly loaded to minimize segregation.

Just as it is important to deliver mix into the silo in a mass, it is also important to deposit the HMA in a mass into the haul truck. The gates on the bottom of the cone of the silo should be opened and closed quickly. It is also necessary for the gates to open completely so that the flow of mix is unrestricted. There is only one

reason to cut off the flow of mix into the vehicle once that delivery has started and that is to divide the delivery of the mix into different sections of the truck. If the HMA is placed in the haul vehicle in one drop from the silo, segregation of the larger aggregate particles can occur. If the HMA is deposited into the center of the truck bed, the material will build up into a conical-shaped pile, as illustrated in Figure 5-3. Because the growth of the pile will be restricted by the sides of the truck, the bigger aggregate particles will roll toward the front and the tailgate of the truck bed. These pieces accumulate at both ends of the load and are then delivered into the hopper on the paver from the truck bed. The pockets of coarse material then appear in the mat behind the paver at the end of the truckload of mix. In reality, some of the large aggregate pieces come from the end of one truckload and also from the beginning of the next truckload of mix. This is called **truck end segregation**.

Truck end segregation problems can be minimized by dividing the delivery of the asphalt mix from the silo into multiple drops, each delivered to a different section of the truck bed. The first drop of mix should be into the front portion of the bed and the second drop should be near the tailgate. The remaining mix should be delivered in evenly divided drops into the rest of the length of the truck bed. **Use caution when loading continuously.** This operation may cause the coarse aggregate particles to collect at the tailgate of the truck and increase the amount of segregation that may occur. If this type of problem occurs from loading continuously, then the



multiple drop sequence shown in Figure 5-4 should be used.

The objective is to minimize the distance that the coarser aggregate pieces can roll. This significantly reduces the chance for segregation in the mix. This procedure, however, requires that the truck driver reposition the truck under the silo after each drop so that the asphalt mix is spread more evenly on the truck bed. In any case, the truck **should not be loaded with one drop of mix** from the silo, even if the mix does not have a tendency to segregate. Multiple discharges are very beneficial in keeping the mix uniform. Some plants are equipped with controls to deposit the mix automatically into the haul truck at predetermined amounts and intervals.

Placement Equipment

Placement equipment is used to place the HMA as pavement. Where feasible, the HMA should be placed and spread by a self-propelled mechanical spreader or paver. Mechanical, self-propelled pavers should be capable of spreading the mix within the specified tolerances specified and true to the line, grade, and crown indicated on the plans.

Pavers should be equipped with efficient steering devices and should be capable of traveling both forward and in reverse. They should be equipped with hoppers, feeding equipment and distributing screws that place the mix in front of the screed. The paver screed unit should be capable of adjusting its height above the roadbed and provide for the proper cross slope and/or crown. It should be equipped with a controlled heating device for preventing the HMA mixture from sticking to the screed at the initial start of paving and at any other time when needed to prevent the HMA mixture from sticking to the screed. The screed should strike off the mix to the depth and cross-slope specified without the aid of guide adjustment during operations. Pavers should be capable of spreading mixes without segregation or tearing and producing a finished surface of even and uniform texture.

Modern pavers are supported on crawler treads or pneumatic-tired wheels. These machines can place a layer of less than 25 mm (1 in.) to approximately 250 mm (10 in.) in thickness over a width of 1.8 to 9.8 m (6 to 32 ft). Working speeds generally range from 3 to 20 m (10 to 70 ft) per minute. The paver operator should keep an even height of HMA on the augurs so the mix is uniformly spread by the screed. A non-uniform height of material will produce an uneven finished product when compacted. Emptying the receiving hopper of the paver and lifting the wings after each truck load of HMA tends to produce segregation in the pavement mat.

Compaction Equipment

Compaction equipment is used to compact the HMA to attain the required density of the HMA mat after placement. The compaction equipment should be of the type or types that will produce the required density and pavement smoothness. A quality HMA mat is obtained by the proper compaction of the HMA. It should not show any unevenness or any roller marks when completed.

Typical compaction equipment used today is usually tandem smooth steel-wheeled rollers; with a weight of eight to fifteen tons with hydrostatic drives on both the front and rear drum. When compacting the mat the forward roller should be pulled not pushed onto the hot mat. Most rollers are capable of a vibratory operation for the initial break down of the HMA mat. Rollers should be in good working condition and equipped with a reversing clutch for both forward and reverse operation at a constant speed. Rollers should have adjustable scrapers to keep the smooth drum surfaces clean and an efficient means of keeping them wet to prevent HMA mix from sticking. These surfaces should have no flat areas, openings, or projections that will mar the surface of the pavement. Steel wheel rollers can be used for the completed compaction and finished rolling of the mat. The final pass of the roller should remove the roller marks and leave the surface flat and blemish free.

Pneumatic-tired rollers are also used to compact the HMA mat. Pneumatic-tired rollers should be self-propelled. The rollers should be equipped with pneumatic tires of equal size and diameter that are capable of exerting uniform contact pressure. Pneumatic rollers can be used for the initial breakdown of the mat as well as the intermediate compaction.

The rubber tires of the roller exert a kneading action as well as varying amounts of contact pressure. The wheels should be spaced so that one pass will accomplish a complete coverage equal to the rolling width of one that not The rollers should be constructed so the contact pressure will be uniform for all wheels and the tire pressure of the tires will vary more than five pounds per square inch. Reducing tire pressure will reduce the contact pressure, thus increasing the tire pressure will increase the contact pressure. rollers should be constructed with enough ballast space to provide uniform wheel loading as may be required. The operating weight and tire pressure of the roller may be varied to obtain contact pressures that will result in being able to obtain the specified density.



Cold Milling

Cold milling is the most common pavement scarification method of salvaging material and for adjusting the grade of existing pavement prior to an overlay. This method uses a self-propelled milling machine with a rotating drum type head containing special teeth that cut the pavement to a predetermined depth and reduce the size of the salvaged material. Single-pass cutting widths of up to twelve feet and depths of four inches have been attained with this type of machine. The cutting heads are hydraulically controlled and are capable of maintaining road profile and depth of cut to one eighth of an inch. Milled material is usually suitable for hot or cold recycling with little additional reduction.

CONSTRUCTION PRACTICES

PREPARATION OF SUBGRADE

The performance of a HMA pavement under traffic is directly related to the condition of the surface on which the pavement layers are placed. For a full-depth asphalt pavement, if the condition of the subgrade soil is poor (particularly if it is wet and rutted under the haul trucks) the ultimate durability of the roadway may be reduced. For HMA layers placed on top of a new, untreated granular base course, that base material should be stable and the surface should be dry and should not be distorted by the trucks carrying mix to the paver.

Preparation of the subgrade, the foundation area that will support the pavement structure, consists of removing the large rock, vegetation, debris, and topsoil from the area that will form the foundation of the roadway. To prevent future growth of vegetation, the subgrade should be treated with an approved herbicide.

The subgrade should be properly shaped to meet the grade and slope shown on the plans. It should be compacted with moisture control to not less than ninety five percent of maximum laboratory density as per ASTM D 698 or D 1557. The surface of the compacted subgrade should not vary more than three-quarters of an inch ($\frac{3}{4}$ ") from the established grades.

Areas showing pronounced deflection under construction traffic indicate instability in the subgrade. If the situation is not corrected by reworking and additional rolling, the areas could be removed and replaced with suitable material and compacted or other options could be considered such as chemical stabilization, fabric bridging etc. If the area is removed HMA millings or coarse granular material is recommended for the replacement material. Very poor subgrade soils can possibly be bridged using geosynthetic fabrics. When this situation is encountered, a qualified materials consultant should be consulted to determine the best method for remedy.

When pavement sections are to be constructed over fine-grained subgrade it is recommended that a separation fabric be used to keep the fine-grained subgrade from migrating up into and contaminating the more open graded base and drainage materials of the pavement section.

Drainage and utility facilities should be installed and their trenches properly backfill and compacted to meet the requirements of the subgrade.

BASE COURSE

A base course can be either a layer of granular material (aggregate) placed on the subgrade and compacted or, in the case of Full-Depth asphalt pavement, a layer of HMA. In either case, the base must be uniform in strength and within grade tolerances as required by the specifications. In addition, the surface should be free of debris and accumulations of dust. If the base course is an unbound material and has been primed with a cutback asphalt, the prime coat should be cured and swept with a power broom to remove loose particles from the surface prior to placement of the HMA course. If the base course is an HMA base it should be swept with a power broom for removal of loose particles and dust. A tack coat is applied just prior to placing subsequent pavement layers.

Untreated Aggregate Base

The crushed aggregate base course may consist of one or more layers placed directly on the prepared

subgrade. The material should be spread and compacted to the required depth, grade and slope, density, and dimensions indicated in the plans or as specified. The minimum compacted thickness of each lift should be no less than two times the size of the largest aggregate particle, or four inches, whichever is greater. The maximum compacted lift thickness should be six inches.

HMA Base

A HMA base may consist of one or more courses of HMA placed on a prepared subgrade. It should have a total compacted thickness as indicated on the plans or as specified. In general, a base with total thickness of four inches or less should be placed in one lift. A base with a total thickness of more than four inches may be placed in two or more lifts with the bottom lift having a minimum thickness of three inches. HMA bases are generally coarse graded mixes with low percentage of asphalt binder compared to the surface course.



HMA bases placed directly on the subgrade should have a lateral or edge drain system construction at their edge. This will help prevent the runoff from the roadway section from getting in under the HMA

base and weakening the subgrade.

PRIME COATS AND TACK COATS

Prime coats and tack coats are applications of liquid asphalt applied to base material or lower layers of the pavement to ensure a bond between the base course and the pavement.

Prime Coat

Prime Coats: A prime coat is a sprayed application of a medium curing cutback asphalt or emulsified asphalt applied to a base course of untreated material. Any time there is a chance of slippage of the HMA, or if there is going to be a delay before paving, a prime coat should be used.

When a medium curing cutback asphalt is used, it is applied heavily enough to penetrate into the base material. When an emulsion is used, it penetrates more slowly and is applied at a lesser rate. A mixing grade asphalt emulsion can also be used, but it must be mixed into the base material by a motor grader, or rotary mixer type equipment. This can be done at the time of final grading and rolling of the base material. Prime applications are done under the same general weather conditions as paving; however, for cutbacks to properly cure, 24 to 72 hours of favorable weather are required.

If the HMA pavement is less than 100 mm (4 in.) thick, a prime coat is recommended prior to placement of the mixture unless prevailing circumstances prohibit it. Circumstances of this nature are when foot traffic is present, there is a strong possibility of moisture getting on the base course, or the project cannot be closed for proper curing time.

A prime coat has three purposes:

1. It fills the surface voids and protects the base from weather.

2. It stabilizes the fines and preserves the base material.
3. It promotes bonding to the subsequent pavement layers.

Application rates for prime coats vary with the type of asphalt used. For a medium-curing cutback asphalt, MC-30, 70 or 250, the application rate ranges from 0.2 to 0.5 gal/yd². When an emulsified asphalt coat of CSS-1, CSS-1h, SS-1, SS-1h, MC-70, or an approved alternate is used, application rates vary from 0.1 to 0.3 gal/yd²/in. depth. Emulsified asphalt prime can be applied at the same rate as emulsified asphalt. Exact application rates are determined by the project engineer under the prevailing conditions at the time the work is done. Application of the MC-250 as a prime should be reserved for open textured bases.

When cutback asphalt is used, the ideal prime rate is the amount of material that the aggregate base will absorb in a 24-hour period. Occasionally, too much cutback asphalt is applied. Even after a normal curing time (24 to 72 hours), some of the asphalt still has not been absorbed into the base. To prevent bleeding of the prime coat up through the asphalt pavement, or creating a slip plane, the excess cutback should be blotted with clean sand or screenings. Blotting involves spreading material over the primed surface and allowing the asphalt prime to be absorbed into the cover material. Paving should be delayed until the excess prime has been properly handled. The area may require a second blotting prior to placement of the HMA. Before the HMA is placed, the prime coated base should be swept lightly with a power broom. Excess sand left in place will prevent a good bond between base course and asphalt layers. Prior to paving, the primed base should be inspected to make sure it has properly cured.

The undiluted application rate should vary between 0.10 and 0.50 gallons per square yard depending on the grade being used. Before paving, any excess prime coat should be blotted with sand, swept and allowed to cure a minimum of 24 hours.

Tack Coat

Tack coats are applications of asphalt (usually diluted emulsified asphalt) sprayed on the surface of an existing pavement prior to an overlay. The purpose of a tack coat is to promote the bond between the old and new pavement layers. Tack coats are also used where the HMA comes in contact with the vertical face of curbs, gutters, cold pavement joints and structures.

A tack can be either CSS-1, CSS1-h, SS-1, SS-1h, MC-70 or an approved alternate at an undiluted rate of 0.02 to 0.10 gal/yd². Two essential properties of a tack coat are: (1) it must be very thin, and (2) it must uniformly cover the entire surface of the area to be resurfaced. To accomplish these requirements and for the distributor to uniformly apply light quantities, the tack asphalt is usually diluted 50:50 with water, and the rate should be adjusted for an undiluted application rate.

The upper limit of the application range is recommended for old oxidized, cracked, pocked, or milled asphalt pavements and concrete pavement surfaces. Too little tack coat will not provide a bond, resulting in slippage cracks, and too much can cause slippage between the old and new pavement layers. In addition, too much tack could cause bleeding into the overlay mix compromising mixture stability. The exact application rate should be determined by the project engineer at the time of application.

Although asphalt cements or cutbacks can also be used for tack coats, a diluted, emulsified asphalt (one part water to one part emulsified asphalt) gives the best results.

Tack coat applications are made under the same general weather conditions as HMA paving operations.

The roadway surface should be dry and free from dusty material. A power broom is used to sweep the surface prior to tack application. Tack coats are applied just prior to placement of the HMA. If the tack is applied too far out in front, it could lose its tacky characteristic and the surface would require additional tack. The element of time for this to occur is a function of the temperature, wind, surface condition and traffic. If an area is tacked and placement of HMA is not done the same day, the surface should be re-tacked lightly at the beginning of the next paving day.

Before the emulsion *breaks* (the water in the emulsified asphalt begins to evaporate and the asphalt begins to bond with the old pavement surface), a tack-coated surface is slick. Traffic should be kept off the tack coat until no hazardous condition exists, and should be warned of the probability of the emulsion spattering when traffic is permitted on it. The overlay should not be placed until the tack coat has cured to the point where it is tacky to the touch.

PLACING OF HMA SURFACING

Before the paving operation begins, the following list items needs to be rechecked and made sure that necessary inspections and preparations have been made and the surface to receive the HMA surfacing ready.

1. Base or roadway surface properly prepared;
2. Plan for execution of work;
3. Proper balance of mix production, spreading and rolling;
4. Equipment in good condition and adjustments made;
5. Provision for weighting the mix have been made; and
6. Plans for sampling and testing.

Binder and Surface Courses

Uniformity of operations is essential in asphalt hot-mix paving. A uniform, continuous operation of the paver produces the highest quality pavement. There is no advantage in the paver traveling at a speed that requires the mix to be supplied faster than the plant can produce it or that it can be trucked to the job site. Trying to pave too quickly can result in the paver having to stop frequently to wait for trucks to bring more mix. If the wait is too long (more than a few minutes on a cool day) the smoothness of the pavement will suffer when the paver starts up again as the mix in the paver that has cooled off is used up.

Obviously, then, it is essential that plant production and paving operations be coordinated. The paver must be continuously supplied with enough mix. In addition, the trucks should not have to wait a long time to discharge their loads into the paver hopper.

Lift Thickness

In the past, the most common rule of thumb for lift thickness was 2 to 1. The lift thickness was recommended to be twice as thick as the maximum aggregate size. At that time, the maximum aggregate size was generally referred to as the first sieve that had 100 percent of the material passing.



of
is



Now with Superpave, the nominal maximum aggregate size is specified and usually 100 percent of the material does not pass this sieve size. So a mixture that used to be $\frac{3}{4}$ " (19 mm) maximum size is likely now to be referred to as $\frac{1}{2}$ " (12.5 mm) nominal size.

So without any other changes, one should now use an approximately **3 to 1** ratio instead of the old 2 to 1 ratio based on the nominal maximum aggregate size. The coarser Superpave designed mixtures also have a higher coarse aggregate content so the ratio should be increased in consideration of the high coarse aggregate content. As

a general rule of thumb, it is recommended for Superpave designed mixtures that the layer thickness should be equal to or greater than three times the nominal maximum aggregate size.



If the mat being placed is uniform and satisfactory in texture, and the thickness is correct, no screed adjustments are required. But when adjustments are required, they should be made in small increments and time should be allowed between the adjustments to permit the paver screed to complete reaction to the adjustments sequentially.

It is equally important that the thickness controls on the screed not be adjusted excessively either in amount or frequency. Every adjustment of the thickness controls results in a change in elevation of the mat surface. Excessive changes in the surface elevation at the edge of the first mat are extremely difficult to match in the

companion lane when constructing the longitudinal joint.

Successive lifts of mix should not be constructed directly over each other, but offset not less than 6 in. (150 mm) on alternate sides of the centerline on succeeding lifts. For example, on a 24-ft (7.3 m) pavement, the first course (lane) is 12½ ft (3.8 m) wide and the next lane 11½ ft (3.5 m) wide. This prevents a continuous vertical seam through the completed pavement along the longitudinal joint. On narrow roads, 20 ft (6.1 m) in width or less, the course which requires the use of a cut-off shoe should be laid first, with the other side being laid full width of the screed. On the final (top) course, a cut-off shoe should be used on both passes so that the joint is located on the centerline.

Alignment of the mat is dependent on the accuracy of the guideline provided for the pavement operator and his alertness in following it. Attention to this detail is vital to the construction of a satisfactory longitudinal joint, since only a straight edge can be properly matched to make the joint.

On a wide roadway, where multiple lanes are being placed, it is generally best to place the lane adjacent to the crown first, and then match the adjoining lane to it.

There are places on many jobs where spreading with a paver is either impractical or impossible. In these cases, hand spreading may be permitted. Placing and spreading by hand should be done very carefully and the material distributed uniformly so there will be no segregation of the coarse aggregate and the asphalt. When the asphalt mix is dumped in piles, it should be placed far enough ahead of the laborer to necessitate

moving the entire pile. Also, sufficient space should be provided for the workmen to stand on the base and not on the mixed material. If the asphalt mix is broadcast with shovels, almost complete segregation of the coarse and fine portions of the mix will result. A mixture placed by hand will have a different surface appearance than the same mixture placed by machine.

The material should be deposited from the shovels into small piles and spread with lutes. In the spreading process, the material should be thoroughly loosened and evenly distributed. Any part of the mix that has formed into lumps and does not break down easily should be discarded. After the material has been placed and before rolling starts, the surface should be checked with templates and straightedges and irregularities corrected.

Joint Construction

Pavement joints are seams between adjacent mats. Construction of durable joints is a critical element in the longevity of HMA pavements. Conventional equipment and techniques can be successfully used to construct both transverse and longitudinal joints. However, due to loss of experienced personnel and a variety of pressures placed on the construction process, it has been suggested that improvements in construction equipment to assist the operator in building high performance joint, especially longitudinal joints, would be extremely beneficial.

Transverse Joints

A transverse joint occurs at any point where the paver ends work and then resumes work at a subsequent time. A poorly constructed transverse joint is noticeable as a pronounced bump in the pavement. Consequently, the inspector must be on hand whenever a transverse joint is made in order to ensure it is done properly. Discovering hours after construction that a transverse joint is unsatisfactory does no good, because joint construction can only be corrected while the mix is still hot and workable. Once the mix cools, corrections be made only by cutting out and replacing joint.

Longitudinal Joints

Longitudinal joints occur wherever mats are



can
the

laid
side
by
side.
The
re
are
two
typ

es of longitudinal joints: hot joints and cold joints. Hot Joints are formed by two pavers operating in echelon. The screed of the rear paver is set to overlap the mat of the front paver by 1 or 2 inches (25 to 50 mm).

The advantages of a hot joint are that the two mats are automatically matched in thickness, the

density on both sides of the joint is uniform because both sides are compacted together and the hot mats form a solid bond. The disadvantage is that traffic cannot move in one of the lanes while the other is being paved. Both lanes are blocked simultaneously.

In a cold joint, one lane is placed and compacted; the companion lane is placed against it and compacted. Special precautions must be followed to ensure a joint of good quality. The base on which the companion lane is to be placed should be swept if necessary. The edge to be joined should be tack coated. The paver screed should be set to overlap the first mat by 1 or 2 inches (25 to 50 mm). The elevation of the screed above the surface of the first mat should be equal to the amount of roll-down expected during compaction of the new mat.

The coarse aggregate in the material overlapping the cold joint should be carefully removed and wasted. This leaves behind only the finest portion of the mixture, which will be tightly pressed into the compacted lane at the time the joint is rolled.

The placement of a Superpave mix is very similar to a conventional mix, however, compaction is the area where Superpave has made its biggest impact. Compaction of Superpave mixes is covered in the section on compaction.

The CAPA/CDOT Longitudinal Task Force has developed a **BEST PRACTICES FOR LONGITUDINAL JOINT CONSTRUCTION** guideline and has been working on the development of a performance based (end result) specification for longitudinal joints. The guideline of best practices for longitudinal joint construction is as follows:

1. BE CONSISTENT:
Decide on a plan and stick with it.
2. COMMIT TO A GOOD JOINT:
Quality contractors build quality joints.
3. MAINTAIN A PROPER TAPER:
Tapers range from near vertical to 12:1.
Regardless of what taper is used, keep it consistent.
Vertical edges and notches as vertical as possible.
Keep edges confined as long as possible.
Maintain a proper "head of material".
4. MAINTAIN PROPER OVERLAP:
Keep overlap consistent typically from 0 - 1½ inches.
Place proper amount of HMA at the joint - too little will allow water to enter, too much will cause a ridge which will carry water and interfere with compaction.
Do not rake joint! If raking to correct improper amount of material, just bump it, **do not** broadcast loose mix across the mat.
5. USE PROPER ROLLING TECHNIQUES:
Start rolling on the confined edge, finish on the unconfined edge.
Roll entire mat except within 6" to 8" of unconfined edge. Compact this edge last while maintaining minimum overlap.
When the hot lane is placed next to the cold side roll it ASAP maintaining minimal overlap onto cold mat.

The performance based specification will require a minimum of 90% of the Form 43 Rice on 6-inch cores directly over the longitudinal joint.

Minimum Grade

It is recommended that the minimum horizontal pavement grade (cross slope) be not less than two percent (approximately one quarter inch per foot) for roadways. For parking lots and playgrounds, to ensure proper surface drainage, a one percent (1%) slope is recommended as a minimum. Slopes usually less than 1% are hard to construct without the formation of "bird baths" which will lead to the deterioration of the pavement surface.

COMPACTION OF HMA PAVEMENTS

Compaction is the process of compressing a given volume of HMA into a smaller volume. It is accomplished by pressing together the asphalt coated aggregate particles, thereby eliminating most of the air voids (spaces) in the mix and increasing the density (weight to volume ratio) of the mixture. Compaction is considered successful when the finished mat reaches optimum void content and density.

The need for a pavement to be compacted to its optimum density is better understood when the effect of air, water, and traffic on an under-compacted pavement is realized. The voids in an under-compacted mix tend to be interconnected and permit the intrusion of air and water throughout the pavement. Air and water carry oxygen which oxidizes the asphalt binder in the mix causing it to become brittle. Consequently, the pavement itself will ultimately fail as it can no longer withstand the repeated deflections of traffic loads. The internal presence of water at freezing temperatures can also cause an early failure in the pavement from expansion of the freezing water .

A pavement which has not been adequately compacted during construction will rut or groove from the traffic that is channelized over it. However, unless some voids are left in the compacted mix, the pavement will flush and tend to become unstable due to the reduction of voids content under traffic and thermal expansion of the asphalt. If the air void content is too high, the pavement will tend towards raveling and disintegration. When there is a low air voids content, there is a danger of the pavement flushing and becoming unstable.

By pressing the aggregate particles close together into a position in which the asphalt binder can hold them, compaction accomplishes two important goals. It develops the strength and stability of the mix. Additionally, it closes gaps through which water and air would otherwise penetrate and cause faster aging, freeze-thaw damage, and stripping.

The temperature at which an asphalt mixture is produced affects both the ease of compaction and the time it takes for the mix to cool to 185 °F (85 °C), the minimum temperature at which densification can take place. Up to a certain point the hotter the mix, the more fluid the asphalt and the less resistant the mix is to compaction. The upper limit for mix temperature is approximately 325 °F (163 °C). Higher temperatures may result in damage to the asphalt. Within these limiting values 185 °F to 325 °F (85 °C to 163 °C), the best temperature to begin rolling (compaction) is the maximum temperature at which the mix will support the roller without moving horizontally.

At the time of placement, the mix temperature is uniform throughout the thickness of the mat. However, the top and bottom surfaces cool more rapidly than the interior because they are in contact with the cooler air and subgrade.

Heat checking is a rather common occurrence during compaction of HMA mixes, particularly when the mix is placed in thin lifts. Heat checking happens most frequently when the tiller wheel of the roller is in front in the direction of travel during the breakdown pass.

Testing and Establishing a Rolling Pattern

For paving projects, a test strip should be constructed to determine the optimum number of roller passes needed to achieve proper density levels. A number of different combinations of rollers and rolling patterns should be tried to determine the optimum combination of compactive effort to achieve the required density smoothness. Setting up a test strip can be one of the most important steps in determining the way to get the desired density and smoothness while also getting the best production.

It is important to establish a test strip under conditions which will closely approximate the job conditions. To provide a minimum strip of at least 500 ft (150 m), it is important to ensure that the mix design is proper, and that the proper mat temperature, thickness and texture are known before rolling begins.

Using a predetermined number of rollers (static or vibratory) and a predetermined roller pattern, roller passes are begun. Density is checked with a nuclear gauge after each roller pass. As a rule of thumb, the roller passes should be completed before the mix cools below 175°F (80°C). Below this temperature, increased compaction becomes more difficult to achieve. Different mixes will have different minimum temperature requirements, some higher, some lower than the "rule of thumb." The specific mix and asphalt properties", will control compaction.

After completing the tests, record the data necessary to duplicate the results on the job (i.e., numbers of rollers, size, type, speed and in the case of vibratory rollers, the frequency and amplitude settings). This being completed, the number of rollers necessary to keep up with the plant and paver production can be selected. The roller pattern should be maintained as was determined on the test strip. Spend as much time with the roller operators as with the paving crew to insure that established procedures are being maintained.



Handling Tender Mixes

Another problem that could be experienced during the compaction of the HMA mix is its lateral movement causing shallow hairline cracks. This condition occurs when the HMA mix is in its **tender zone**. Working with tender mixes continues to be

an issue in the placement of some hot mix asphalt pavements. Tenderness, although only experienced on a small percentage of projects, has been experienced for years. With the implementation of Superpave, tenderness has attracted more attention.

The cracks that develop during the tender zone do not cause a significant problem themselves; however, they could allow moisture to penetrate the mix reducing durability. In addition the cracks could grow and cause premature failure of the pavement. If a tender mix is successfully compacted to the desired density level it may not experience significant loss of life; however, smoothness could be affected.

There are many causes attributed to tender mixes and identifying the specific cause on a given project may be difficult. Some of the potential causes of the tender zone are listed below:

- Moisture
- Excess Asphalt Content
- Rounded Aggregates
- Aggregate Gradation
- Binder Stiffness
- Excessive Mix Temperature
- Asphalt Binder Light Ends
- Rolling Equipment and Techniques
- Inadequate Bond to Underlying Layer
- Contamination

Moisture could be from improperly dried aggregates, moisture on the surface prior to paving or from excessive moisture applied during the initial compaction process. The process of converting the water to steam, which increases the volume of the water, tends to push the aggregates apart.

Excessive asphalt content is a relative term and is a function of the mixture. When the mix is designed properly, this should not be a problem.

Rounded aggregates have been associated with tender mixes for some time. Rounded particles tend to roll past other aggregates, resulting in lateral movement.

The **gradation of the mixture** could be a problem. For example, if the filler content is too low, there is not enough fine material to mix with the binder to produce adequate stiffness. Generally well-graded aggregate mixes do not exhibit tenderness.

The **bond to the underlying surface** could lead to some tenderness. When overlaying a smooth oxidized surface or one where some loose materials exist, it may be difficult to establish an adequate bond, allowing lateral movement of the overlay. When a mix is placed too hot, the rollers may have to wait for the mix to cool enough to begin compaction. At this point the mix at the surface may be at a lower temperature than the center of the mix, causing a stiffer upper layer to slide over the hotter less stiff center mixture. Mixes should be placed at a temperature at which compaction can begin immediately.

Some **asphalts have light ends** that may be driven from the mix in the range of 300° - 350° F. There have been occasions when a change in the source of asphalt cement has solved the problem.

Rolling equipment and operator technique can have a significant effect on how the mix handles during compaction. Mixes that appear tender under steel wheel rollers will not typically act tender under rubber tired rollers. Sudden starts and stops and sharp turns of the rollers are likely to shove the mix laterally. Typically the drive drum of the roller should be run toward the paver.

Binder stiffness may be too low at very high temperatures, which will make the mix appear tender. Polymers, which stiffen the mix, are less likely to exhibit tenderness when being compacted if the breakdown rolling is completed before the mix cools below 275° F.

Contamination with diesel fuel or other petroleum solvents can cause tender mix problems. Contamination can come from storage tanks, release agents in trucks, spills on the existing surface or many other sources.

Colorado is not unique in that tenderness is an issue here as well. Numerous contractors have been consulted and most agree that compacting the mixture as much as possible prior to the temperature falling into the tender zone seems to work the best. Some have been able to achieve the specified density prior to the mix temperature falling into the tender zone. They then wait until the mix has cooled sufficiently and take out the roller marks as usual.

Others contractors experimented with using the rubber tired roller to roll in the breakdown mode and were successful. Some adjusted the frequency and amplitude of the breakdown roller to assist in more rapid compaction. Most agree that the tender zone is more of a temperature problem than a grading issue.

Generally speaking, it is easier to achieve target density in thicker layer (lifts) of HMA than in thinner ones. This is because the thicker the mat the longer it retains its heat and the longer the time during which compaction can be achieved. This can be used to advantage when rolling lifts of highly stable mixes that are difficult to compact, or when paving in weather that can cause rapid cooling of thin mats. Alternatively, increased course thickness can permit lower mix temperatures to be used because of the reduced rate of cooling.

It is very important to recognize that operating techniques are governed by the mix behavior during the rolling process. It will vary from job-to-job and from lift-to-lift. Rules are, therefore, not absolute, but only considered as guidelines.

Superpave mix compaction is the area where Superpave has made its biggest impact. Meeting compaction requirements has been challenging on some Superpave projects. Due to higher amounts of angular materials in Superpave mixes, it can be a little more difficult to compact. Coarse graded Superpave mixes are where most of the compaction problems have been. Coarse graded mixes often cool faster, allowing less time for compaction. The contractor may need to employ the use of additional rollers, to compensate for less time available to achieve compaction.

With a Superpave mix, it is very important to start rolling the mat while it is really hot (280-300 F). For a stiff mix breakdown rolling should be done right up close to the paving machine, it is crucial to get compaction before it cools down. The roller size may need to be increased from a 12-ton to a 17-ton roller to get the necessary compaction.



For Superpave mixes that exhibit tender characteristics under the rollers, it is important to get the breakdown rollers right behind the paving machine to obtain as much compaction as possible before it cools into the tender zone temperature range. When a mix becomes tender, steel wheeled rolling should be stopped or the mix will be damaged. A pneumatic roller can be used effectively in the tender zone without damaging the pavement. When the mix cools and becomes stable again, steel wheel rollers can be used to finish the job of compaction.

COLD WEATHER PAVING

Potential damage to roadways as a result of frost action is of primary. Frost action essentially has two aspects. The first is that, during winter months, ice lenses can form beneath the surface of the ground causing a heaving of the surface. Such bumps on the road surface are not conducive to travel by high-speed traffic. The second aspect of the frost action problem occurs when ice lenses begin to melt. The melting starts during the spring of the year and proceeds from the surface downward. As a result, water from the melting ice is trapped in the near-surface region, causing a high degree of saturation which can lead to significant reduction in subgrade strength and thus a failure of the pavement. Consequently, due to potential damage which can result from frost action, an evaluation of the frost susceptibility of proposed subgrade soils and the effect on pavement design is important.

Evaluation of Frost Effects

Evaluation of frost potential in soils is a critical aspect of the design of pavements and embankments. To

ensure satisfactory design, it is necessary that the potential effect of frost action on the structure under consideration be assessed.

As previously mentioned, frost action has two components: 1) the heaving of the ground caused by the formation of ice lenses near the ground surface, and 2) the weakening condition of the soil when the ice lenses melt, melting from the top down and producing ponding or saturated condition in the near-surface soil.

Three elements are required for frost action: a frost susceptible soil, freezing temperatures, and the presence of water. If any one of the aforementioned elements are missing, frost action will not be a problem. Frost susceptible soil may be recognized on the basis of the particle size distribution, in the manner previously cited, or actual tests can be conducted in the laboratory to ascertain the degree of frost susceptibility

Criteria have been established for determining the frost susceptibility of soils based on particle grain size distribution. Such a classification has been published by the U.S. Army Corps of Engineers and is shown in Table 5-2.

Table 5-2 Frost Susceptible Soils

Group	Description
F1	Gravelly soils containing between 3 and 20 percent finer than 0.02 mm by weight.
F2	Sands containing between 3 and 15 percent finer than 0.02 mm by weight.
F3	A) Gravelly soils containing more than 20 percent finer than 0.02 mm by weight, and sands, except fine silty sands, containing more than 15 percent finer than 0.02 mm by weight. B) Clays with plasticity indices of more than 12, except C) Varied clays existing with uniform conditions.
F4	A) Silts including sandy silts. B) Fine silty sands containing more than 15 percent finer than 0.02 mm by weight. C) Lean clays with plasticity indices of less than 12. D) Varied clays with non-uniform subgrade.

This criteria is based on the quantity of material finer than 0.02 mm with soils being graded from F1 to F4, in order of increasing frost susceptibility. In general, this table indicates that soils containing more than 3 per cent by weight of particles finer than 0.02 mm are considered frost susceptible. This classification has been found by the Corps of Engineers to be satisfactory and accurate.

Capillarity

Capillarity permits the creep of free water through the pores and fine channels of the soil. In coarse-grained materials such as sand and gravel, the behavior of free water is governed almost entirely by gravity, and the water will tend to seek a level as if in an open channel. As grain sizes become smaller and channel diameters decrease, soil-water interactions influence the behavior of the water. For example, if the pores of a soil are not full of water and if free water is available, capillary forces will tend to pull free water through the soil until the voids are full. Such movement can take place in any direction, but upward movement usually creates the most serious problems. Capillary action is most pronounced in soils composed mainly of fine sands, silts, or silty clays, as they are fairly permeable and have channels through which moisture can pass. Yet the diameters of the openings are small enough so that the capillary forces are high. Clays and colloidal soils are practically impermeable and are little subject to capillarity.

There is evidence that large amounts of water can be raised considerable distances by soils subject to capillarity. If the surface of the soil is open and this moisture evaporates as fast as it rises, no damage may

result. But, if evaporation is slow or the surface is sealed by pavement or some other impervious blanket, this capillary water accumulates and saturates the subsurface layers. Many surface failures have resulted.

Failures Resulting from Frost Action

Failures variously described as frost heaving, frost boils, and spring breakup often are the result of the combination of capillary action with the freezing and thawing of the ground. A simplified explanation of this phenomenon is as follows:

1. When the soil temperature decreases below the freezing point, water in the larger voids freezes, but that in the capillary tubes does not, because its freezing point is lower (see Figure. 5-5) .
2. This capillary water is drawn to the frozen particles with, tremendous force. Tensions as high as 8000 cm of water have been reported.
3. When this water comes in contact with the ice particles, it freezes and increases the thickness of the ice layer, thus raising the overlying material. Pressures of about 200 lb per sq in. can be developed, which far exceed the usual superimposed load.
4. Water drawn from the soil pores is replaced with moisture supplied by capillary action from the groundwater below, and that in turn is added to the growing ice lens.
5. Growth of a lens is halted and another below it begins to form when the temperature between them becomes low enough to freeze the capillary moisture. The rate at which cooling takes place governs the number and thickness of lenses.

In the northern United States, even where the ground seldom freezes more than 2 to 3 ft below the surface, heaving or raising of the road surface by 6 in. or more is not uncommon. In one case heaving of 2 ft has been reported. Very often heaving is not uniform but occurs only in stratified layers or pockets of fine sand,

Figure 5-5 Mechanics of Frost Heave

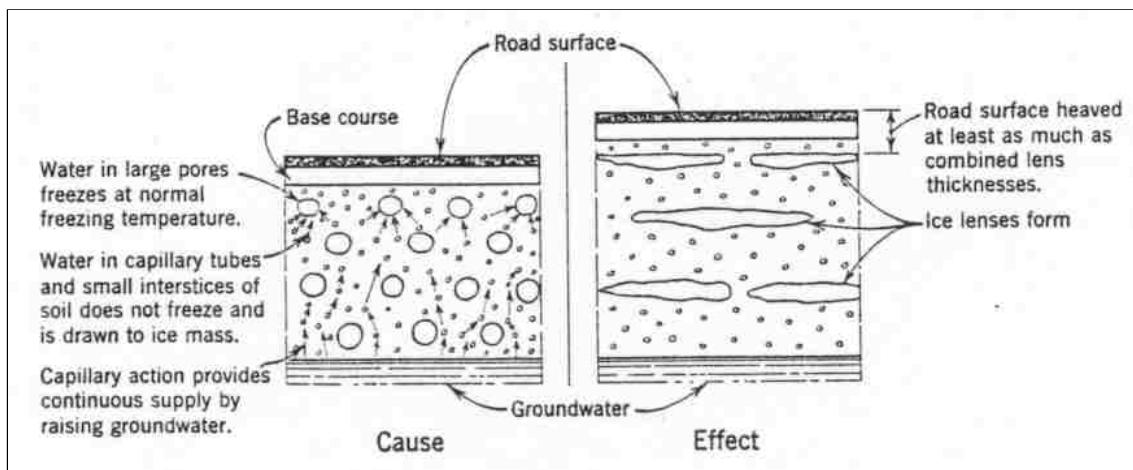

silts, or silty clays which so often occur in regions that have been subject to glacial action. Thus a small section of the road surface will rise and create a serious accident hazard. Unfortunately many subgrade soils whose characteristics vary abruptly occur within the frost areas of this country.

With Spring thaws, the ground and ice lenses melt, and free water under the surface escapes through cracks to form "frost boils." Harmful settlement of the road surface follows. When water remains under the surface until vehicles break through, the action is described as "Spring breakup." Frost action also brings

bank slides and slope instability.

Several remedies for frost heave have been used. Among them are:

1. Remove the soil that is subject to capillary action for a considerable depth and replace it with a granular non-capillary material. The practice varies: some agencies remove susceptible materials to the full depth of frost penetration; others stop at one-half this depth.
2. Install sub-drains to lower the groundwater below the reach of extensive capillary action.
3. Excavate the soil to the frost line and place an impervious seal such as an asphaltic membrane or a layer of granular, non-capillary material at this level to cut off the flow of capillary water. Then replace the original material.

Even where freezing does not bring frost heaving, a marked strength loss results when a frozen subgrade and base thaw. Repeated tests have demonstrated that frozen soils match the supporting power found during the late summer and fall. ***However, as thawing from the surface downward progresses, strength falls rapidly and may decrease as much as 50% by the time the frost is out of the ground. Thus resulting in a pavement structure not capable of supporting the traffic loadings and the eventual deterioration of the pavement.***

Environmental Condition

The construction of quality pavement structures is highly dependent on the conditions under which the pavement is placed. Ambient air temperature, wind, humidity and the temperature of the surface upon which the HMA is being placed can seriously affect the cooling rate of the mixture. The placement and compaction of HMA is basically a race against time. Cool air temperatures, high humidity, strong winds and cool surfaces can shorten the time in which compaction must take place. Increasing plant mix temperature, covering hauling units, minimizing haul length and shortening windrows in front of pick up machines can minimize the effects of the environment.

Layer Thickness

Asphalt mixtures cool with time. The greater the surface area of the mixture, the faster the environment can cool the mixture. Thick layers, or lifts, have less material exposed to the air and subsurface in relation to their volume, and therefore cool slower. Generally, it is easier to achieve required density in thicker lifts of HMA than in thinner ones. This is because the thicker the mat, the longer it retains heat, thus increasing the time during which compaction can take place. This principle can be used to advantage when rolling lifts of highly stable mixtures that are difficult to compact, or when paving in weather that can cause rapid cooling of thin mats. The most effective way to slow the rate of cooling is to keep the mixture in as large a mass as possible. ***Thicker layers can permit mixtures to be placed at lower temperatures because of the reduced rate of cooling.***

Subgrade and Bases

The subgrade or base must be firm and non-yielding under the haul trucks and other construction equipment. Subgrade or bases that show movement under trucks or construction equipment will need additional compaction work or some type of remedial work to overcome the softness. The remedial work could be lime or Portland cement stabilization, or in certain circumstances, removal and replacement with a more suitable

material. A yielding subgrade or base would require a thicker HMA pavement in order to support the traffic loading. Haul trucks may also be limited in size and weight to prevent pumping action of basement materials.

Paving in Cold Weather

As previously discussed, maintaining heat in the mix is critical in achieving density and constructing a quality asphalt pavement. In many areas however, it is necessary to pave when conditions are not exactly favorable. Many times in the early spring or late fall and winter, temperatures can severely hamper or halt the construction process. When paving in cold weather conditions, construction procedures usually need to be altered in order to achieve the specified density. A few things that can be done to achieve density are:

- Work the breakdown and intermediate rollers as close to the paver as possible
- Cover loads during hauling (warm and cold weather paving)
- Insulate the truck beds
- Increase the plant temperature
- Decrease plant production rate
- Minimize or eliminate windrows and pickup machines
- Reduce paving speed
- Increase the number of rollers
- Increase the layer thickness

The basic strategy is to maintain as much heat as possible in the mixture long enough to facilitate attainment of the required density. However, even by observing the above recommendations and achieving the specified level of compaction, detrimental effects can occur when paving during cold weather. As the HMA cools, it cools at different rates. The exposed surface and the surface contacting the cold subsurface will cool at a much faster rate. The top and bottom of the layer will rapidly cool to the surrounding temperature, while the middle portion of the layer (which is often where the temperature is measured) remains much warmer. It is theorized that, when the lift is compacted, the top surface can develop micro cracks as the mat compresses. These micro cracks allow moisture to enter the pavement surface, and moisture damage can be expected. As a result, surface raveling could occur. Raveling is the process where surface fines and binder are lost and "flake" away. The resulting surface will appear porous and rocky as the large aggregate remains in place. This phenomenon is more severe when using marginal or "poor" aggregates and when paving in the fall. Early season paving problems tend to be less prevalent since traffic during the summer seems to "knead" the surface back together.

Perhaps the most common consequence of cold weather paving is inadequate densification of the pavement layer, especially thin surface courses. The lack of adequate density in late paving season often results in raveling, and sometimes disintegration, of the surface course within a few months after paving.

A note of caution, if there is any potential for subgrade swelling due to freezing actions, then the HMA pavement should not be placed based on the previous mentioned subgrade strength loss.

PAVEMENT MARKINGS

Pavement markings have an important function in traffic control. They convey certain regulations and warnings in a clearly understandable manner without diverting the driver's attention from the roadway. An HMA pavement clearly has an advantage in providing highly visible, attention-attracting markings - even under adverse weather conditions. White and yellow painted markings stand out on the black background.

Pavement markings on public highways should comply with the Manual on Uniform Traffic Control Devices (MUTCD). Standards for color, materials, width, shape, and concept are set forth in the MUTCD.

The most frequently used pavement markings are longitudinal center stripe and edge stripe markings. The basic concept is to use yellow lines to delineate the separation of traffic flow in opposing directions or to mark the left edge of pavement of divided highways and one-way roads. Solid yellow lines are also used to mark no passing zones. White lines are used to separate traffic lanes flowing in the same direction or to mark the outside edge (right) of pavements.

The patterns and width of longitudinal lines vary with use. A broken line formed by segments and gaps, usually at a ratio of one to three. On rural highways, a recommended standard is ten-foot segments and thirty-foot gaps. A normal line is four to six inches wide.

It is beyond the scope of this Design Guide to present these standards in more detail. The user should refer to more detailed standards when placing pavement markings. City and County engineering offices and most other transportation engineering organizations have a copy of the MUTCD.

TRAFFIC CONTROL THROUGH WORK AREAS

The control of traffic through work areas in a safe and expeditious manner, while maintaining good public relations, is an essential part of highway construction and maintenance operations. A traffic control plan should be required for construction projects. When a road or a site normally used by traffic is closed, it should be barricaded and signed in accordance with the MUTCD. In today's litigious society, efficient traffic control may mean the difference between no liability and a large financial award should an accident occur. No agency, owner, or company is immune from alleged responsibility for an accident.

Because of the multitude of construction and maintenance applications, it is impossible to list the standards for signs, barricades, and markings in this publication. For more detailed information on a specific application, refer to Part VI of the MUTCD and to the Colorado Department of Transportation.

TESTING AND INSPECTION

Inspection and testing of the production and placement of HMA - or of any material - is necessary to ensure a quality product. Plant produced HMA will have different properties than those measured in the laboratory during development of the job mix formula. Accordingly, it is necessary to re-evaluate and adjust the mix during field production. Plant and field inspections including the following:

- 1 The preparation of the aggregate
- 2 The HMA plant setup and operation
3. The control of the HMA mixture
4. The delivery and placement
5. The finishing and compacting.

Testing consists of performing different physical and analytical tests on the various materials and products that are used on the project. Testing is not an exact science and is subject to some variability and statistical error. There is also a certain amount of bias in testing. Accordingly, acceptance and control of quality for the various parts of the construction process should be based on a statistical mean and deviation from that mean value. Pass/Fail of individual tests should not be used for measuring acceptance or rejection of any part of the construction process.

Testing should generally be performed at three levels:

1. **Quality Control (QC)** testing is performed by the contractor to help control the overall quality of the product being produced. The QC testing is performed at the highest frequency.
2. **Quality Assurance (QA)** testing is performed to access the level of acceptance and how the contractor is to be paid for their materials and work. QA testing is usually performed at less frequency than QC testing. Either the owner or an independent consultant usually performs the QA testing.
3. **Independent Assurance Testing (IAT)**(audit function) testing is performed independent assurance of either QC or QA testing and at much less frequency. The Independent Assurance testing is used to verify the QC and QA testing and is performed on samples that have been split with QC and QA.

Whenever there is an indication that the three testing programs are too far apart in their results the problem needs to be resolved.

It is beyond the scope of this Design Guide to do more than emphasize the importance of a quality testing and inspection program. Project Specials and General Specifications usually state testing frequency, location of sampling, and procedures to be used. The Asphalt Institute and National Asphalt Pavement Association (NAPA) both publish guides on asphalt plant inspection and field-testing which are available for reference. Colorado Asphalt Pavement Association (CAPA) and other organizations offer training courses on these subjects. It is recommended that technicians be certified through the an appropriate certification program such as the Laboratory for Certified Asphalt Technicians (LabCAT).

CHAPTER SIX

GEOSYNTHETICS

AND

THEIR APPLICATION

CHAPTER SIX

GEOSYNTHETICS AND THEIR APPLICATION

GENERAL CONSIDERATIONS

Geosynthetic materials are used for many different applications throughout a roadway or highway design. Not only are they used in asphalt paving installations, they are used for slope stability, drainage enhancement, and as strengthening layers below and within the pavement section.

The primary functions of geosynthetics are listed in Table 6-1:

Table 6-1
Geosynthetic Functions

FUNCTION	DESCRIPTION
Barrier	The use of a geosynthetic material to prevent the migration of liquids or gases.
Drainage (a.k.a. transmission)	The use of a geosynthetic material to collect and transport fluids as in an underdrain system.
Filtration	The use of a geosynthetic material to allow passage of fluids from a soil while preventing the uncontrolled passage of soil particles.
Protection	The use of a geosynthetic material as a localized stress reduction layer to prevent or reduce damage to a given surface or layer. The materials will break any bond between layers of the pavement structure.
Reinforcement	The use of the tensile properties of a geosynthetic material to resist stresses or contain deformations in geotechnical structures.
Separation	The use of a geosynthetic material between two dissimilar geotechnical materials to prevent intermixing.
Surface erosion control	The use of a geosynthetic material to prevent the surface erosion of soil particles due to surface water run-off and/or wind forces.

GEOSYNTHETIC TERMINOLOGY

Terminology and reference to geosynthetics and their application is confusing and often incorrectly stated. According to the International Geosynthetics Society (IGS) the correct terminology for the geosynthetic materials used in the asphalt paving industry are as follows:

Geocomposite - A manufactured or assembled material using at least one geosynthetic product among the components, used in contact with soil/rock and/or any other geotechnical material in civil engineering applications.

Geogrid - A planar, polymeric structure consisting of a regular open network of integrally connected tensile elements, which may be linked by extrusion, bonding or interlacing, whose openings are larger than the constituents, used in contact with soil/rock and/or any other geotechnical material in civil engineering applications.

Geomat - A three-dimensional, permeable, polymeric (synthetic or natural) structure, made of bonded filaments, used for soil protection and to bind roots and small plants for erosion control applications.

Geomembrane - A planar, relatively impermeable, polymeric (synthetic or natural) sheet used in contact with soil/rock and/or any other geotechnical material in civil engineering applications.

Geosynthetic - A planar, polymeric (synthetic or natural) material used in contact with soil/rock and/or any other geotechnical material in civil engineering applications.

Geotextile - A planar, permeable, polymeric (synthetic or natural) textile material, which may be nonwoven, knitted or woven, used in contact with soil/rock and/or any other geotechnical material in civil engineering applications.

Except for some basic applications of geosynthetic fabrics in a pavement section, it is beyond the scope of this design guide to go into further detail regarding the above listed geosynthetic materials. A qualified consultant should be retained for the correct use and application of the geosynthetics and their applications.

HOT MIX ASPHALT APPLICATIONS

In a Hot Mix Asphalt (HMA) pavement section geosynthetic materials generally consist of the following applications:

Filtration fabrics - used for filtration to allow water to pass from one part of the pavement section to another while preventing the uncontrolled passage of soil particles.

Separation fabric - used to prevent two dissimilar materials such as subgrade and bases from intermixing.

Reinforcement fabrics - used to resist stresses within the pavement section and or between the subgrade and the rest of the pavement section. Also used to prevent or retard the propagation of cracks in an old pavement from reflecting up through a new pavement overlay.

Barrier fabrics - used as a waterproofing membrane to prevent the migration of water within the pavement section.

BARRIER FABRICS

One school of thought recommends using barrier fabrics to retard infiltration of water into underlying layers of the Hot Mix Asphalt and the remaining pavement section. The other school of thought recommends not using barrier fabrics because they can trap water and accelerate asphalt stripping. The decision to or not to use a barrier fabric as a water proofing membrane needs to be carefully determined by qualified consultants on a project by project basis.

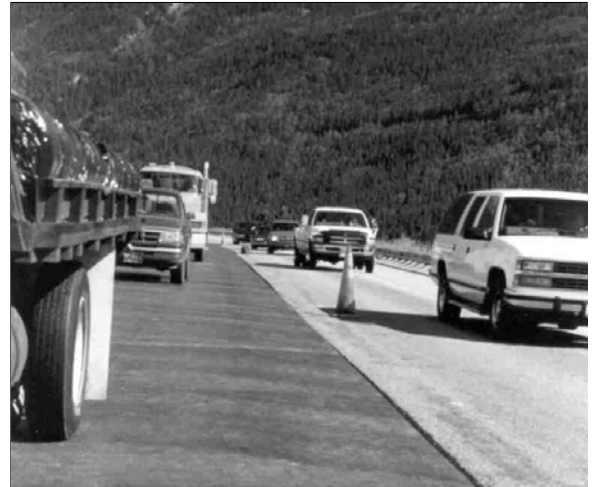

REINFORCEMENT FABRICS

When used, a paving fabric acts as an interlayer in Hot Mix Asphalt (HMA) paving in an effort to:

- Prevent or delay cracks in the old pavement from "reflecting" through as cracks in the new overlay,
- Provide an impermeable barrier to keep surface water from entering the lower layers of the pavement section and subgrade.

In order that the reinforcement fabric performs as intended, the fabric must become saturated with asphalt and bond sufficiently to both the old pavement and new HMA overlay.

The Fabric

Paving geotextiles are usually constructed of non-woven synthetic fibers; resistant to chemical attack, mildew and rot. They should conform to the physical requirements shown in Table 5-2.

Table 6-2
Physical Requirements of Paving Geotextiles

Property	Requirements	Test Method
Tensile Strength	lbs, min 80	ASTM D 4632
Elongation at Break	%, min 50	ASTM D 4632
Asphalt Retention	gal/yd ² , min 0.2	Task Force 25 #8 ¹
Melting Point	° F, or greater 300	ASTM D 276

¹Task Force 25 #8 is a subcommittee of the Joint Committee on New Highway Materials which is made up of representatives of AASHTO, AGC and ARTBA

Paving fabric is usually shipped to the job site in 300 foot rolls, twelve and one half feet (12.5 ft.) wide. During shipment and storage, the fabric should be protected from direct sunlight and water. For those fabrics not pre-qualified, fabric samples should be obtained as early as possible and sent to a qualified lab for testing. It usually is sufficient to take the first eighteen inches (18") (full width) from one roll in every thirty rolls as a standard sample.

Paving fabrics come in various colors depending on the supplier. Normally they are either black or gray.

The most popular used fabric is black, but the gray fabric offers some advantage over the black fabrics in that it is easier to tell if the fabric is saturated and if it has been laid smooth without wrinkles.

Field Quality Control

Prior to the installation of any paving fabric in a paving project, it should be inspected. Described below are field quality control measures that should help the paving fabric to perform as intended. A quick reference inspection checklist is provided at the end of this chapter to help with the inspection of the fabric.

Preparation of the Old Pavement

Prior to placement of the fabric, cracks wider than one quarter of an inch should be sealed. Potholes should be filled to provide a flat, uniform surface for the fabric and to keep the liquid asphalt tack coat from "**puddling**" or "**leaking**" away. If the old pavement exhibits extensive rutting, faulting and step-off joints or cracks, a thin leveling course should be placed prior to placing the fabric.

To ensure a successful overlay project, **the above procedures should be followed even if a contract change order is required.**

Preliminary Tack Coat

After the surface has been prepared, a **heavy tack coat** (usually 0.20 to 0.30 gal/yd², depending on the fabric brand) is applied at temperatures from 300 °F to 350 °F by means of a distributor truck. The spray bar nozzles should be in good working order so as to provide a uniform application. The width of the tack coat should be the width of the fabric plus a maximum of three inches (3") on each side.



The asphalt cement that is most preferred for the tack

coat is PG 58-22. However, in hot weather, a PG 64-22 may be specified. **However, the asphalt cement binder should be the same grade as in the HMA that will be used in the overlay.** The asphalt cement should be sampled.

The application rate (gal/yd²) of asphalt cement placed should be sufficient to:

- Bond the fabric to the old pavement (or leveling course),
- Saturate the fabric, and
- Provide enough excess on the topside of the fabric to bond the HMA overlay to the fabric.



Too light an application rate could preclude any of the above. Too heavy an application rate could result in slippage problems or bleeding at higher temperatures. Therefore, it is of utmost importance that the proper amount of asphalt cement be applied. **Although a nominal application rate of 0.25 gal/yd² is usually specified, very thick or very thin fabrics will usually require more or less than that amount.** Most fabric manufacturers have determined acceptable application rate "ranges" for their brand of fabric. The field application rate can be checked by dividing gallons used by the area covered.

As mentioned above, the liquid asphalt cement must saturate the fabric. This means it must stay liquid long enough for saturation to occur. This can occur in either of two ways:

1. Where the liquid asphalt is applied to a **cool pavement**, it will assume the temperature of the pavement and stiffen within seconds. In this case, the liquid asphalt usually will only remain tacky enough to hold the fabric in place, but saturation will occur when the HMA overlay is placed and its heat (250 °F to 300 °F) re-melts the tack asphalt, allowing it to infiltrate the fabric. With normal rolling pressures, the fabric should become saturated (assuming the application rate was adequate).
2. Where the liquid asphalt cement is applied to a sun-heated (say 100 °F or above) pavement, it often stays liquid enough to saturate the fabric, at least partially, **prior** to placement of the HMA overlay. In this case, **full** saturation usually will occur in the wheel tracks of vehicles that drive on the fabric. This is where problems can arise. The tires of the HMA haul trucks can become coated with the liquid asphalt and will often pick up the fabric as they roll on it. The first reaction is to cut back the amount of liquid asphalt being applied in an effort to dry up the operation and eliminate this problem. **The cutting back of the liquid asphalt should not be permitted** as the long-term performance of the fabric could be sacrificed. The rationale here is that a given brand of fabric requires a fixed amount of asphalt for saturation and bonding. This amount does not change simply because the asphalt stays liquid enough to saturate the fabric **before** placement of the HMA overlay (i.e., where the liquid asphalt does not depend on being re-melted by the heat from the overlay). **Reducing the amount** of liquid asphalt applied could **result in poor bond** between the fabric and the HMA and/or failure to create a waterproof membrane.

If fabric placement problems arise due to general "**soupiness**" of the fabric/liquid asphalt combination, they can be remedied by measures less detrimental **than reducing the amount** of AC applied. Some of these measurements are:

- Hand spreading a small amount of the HMA mix on top of the fabric in the wheel paths of the vehicles,
- Keeping the fabric's placement as close as possible to the paving machine, thereby reducing the time that the fabric is on the tack coat prior to overlay's placement,
- Changing to a heavier (thicker) grade of liquid asphalt, and
- Prohibiting vehicles (other than HMA haul trucks) from traveling on the fabric.

Another problem, related to liquid asphalt application, arises when the operator of the distributor truck follows the practice of spraying an area not more than about 100 feet ahead of the fabric laydown, then stopping and waiting for the fabric to catch up. Upon restarting, they will often *overlap* their previous spray, resulting in a double application. These locations of double application can lead to construction problems, such as sticking to haul truck tires which tend to pick up the fabric, or long-term pavement problems such as bleeding or slippage. Liquid asphalt applications overlaps should therefore be minimized.

Once the tack coat is placed on the pavement in preparation of receiving the bare fabric, traffic must be kept to a minimum. **Vehicle tires will “pick up”** tack coat if allowed to travel over it and rob the fabric of sufficient binder. Limited traffic after placement of fabric is not harmful unless wheel turning or other damaging wheel movements occur.

Fabric Placement

Paving fabric usually is placed by a crew of three using a small tractor or front-end loader rigged for handling rolls of fabric. The fabric can be placed manually (i.e., without the use of a tractor), but this is usually slower, cumbersome, and creates more wrinkles.



As the fabric is rolled onto the liquid asphalt coating, it must be aligned and smoothed to remove wrinkles and folds. Folds that result in a **triple thickness** of fabric must be cut with a knife and lapped slightly. The proper asphalt cement binder application rate will saturate a double layer, but not a triple layer of fabric.

Adjacent borders of the fabric should be lapped only two to four inches. Excess should be cut off. This applies to longitudinal joints, as well as end of roll transverse joints. At longitudinal joints, both liquid asphalt and fabric should overlap previously placed fabric by the same amount.

Because of tire sticking and pick up problems, only a minimal amount of construction equipment should be allowed on the fabric, especially in warmer weather (say above 80 °F). If tire pick up should occur, a small quantity of HMA distributed on the fabric will usually correct the situation.

Rolling equipment may be used to "seat" the fabric in cooler weather where the liquid asphalt coat tends to stiffen and winds tend to displace the fabric.

Overlay Paving

When the Hot Mix Asphalt (HMA) overlay is placed on the fabric, two paving variables are usually the key to proper installation of fabric:

- The temperature of the HMA overlay mix at the time of rolling, and
- The degree of compactive effort applied to the overlay.

Most HMA mixes require **rolling** to commence while the mix is above 250 °F and to be finished by the time the mix has cooled to 150 °F. These requirements should be adequate to cause the saturation of the fabric, assuming sufficient liquid asphalt was applied. It should be remembered that a *thin* overlay will cool quite fast and thereby lose its ability to produce saturation of fabric sooner than a thicker overlay (i.e., 250 °F HMA mix placed one inch (1") thick on a 40 ° F base will cool to 150 °F in about five minutes). Therefore, to assist in fabric saturation, the initial rolling of the HMA pavement should follow the paving machine closely and long windrows should be discouraged. **Laying HMA in a single lift less than two inches thick when using fabric is not recommended.** CDOT specifications do not allow any HMA mat less than two inches in thickness be place on the fabric. Experience has shown that a lift of less then two inches of HMA could result in the HMA overlay popping loose and not adhering to the underlying fabric and asphalt mat. It is recognized that there has been success with new overlay mats of less than two inches being placed with fabric, but extreme caution should be taken to see that the proper procedures and good construction practices be followed.

As a check, a small "dig-out" can be made in the HMA mat after each roller pass to observe if fabric saturation is occurring.

Samples of the HMA overlay mix should be obtained from the mat behind the paver in the normal manner.

CONCLUSION

Knowledge of a few simple rules, combined with common sense, can mean the difference between a trouble free fabric installation and a project that becomes either a construction "nightmare" or a premature pavement failure.

The **Inspection Checklist**, shown below, should be followed on fabric installations.

INSPECTION CHECKLIST FOR PAVING FABRIC

Preliminary Work

1. Sample fabric, and send it to Lab.
2. Store fabric in area protected from sun and water.
3. Determine the brand and grade of asphalt cement to be used, and obtain a sample.
4. Check to verify the liquid asphalt application rate to be used is approved and adjusted for field conditions by the fabric's manufacturer.

Preparation of Old Pavement

1. Sweep surface clean.
2. Seal larger cracks.
3. Place leveling course if needed.

Liquid Asphalt Cement Application

1. Check application rate and temperature, and obtain a sample.
2. Watch for poor application practices such as:
 - a. Frequent stops and starts
 - b. Excessive spread overlaps
 - c. Non-uniform spread

Fabric Laydown

1. Watch for wrinkles, folds, and bubbles.
2. Prevent excessive overlaps.
3. Insure that fabric follows proper alignment.
4. If bleeding occurs, broadcast HMA on fabric to prevent tires from sticking.

Overlay Paving

1. Discourage lengthy windrows of HMA.
2. Check temperature of HMA behind paver.
3. Encourage expeditious, thorough rolling of HMA overlay.

CHAPTER SEVEN

HIGH TRAFFIC VOLUME INTERSECTION DESIGN

CHAPTER SEVEN

HIGH TRAFFIC VOLUME INTERSECTION DESIGN

INTRODUCTION

The following chapter is intended to help the design engineer with designing high performance, high traffic volume asphalt intersections. The guide is a compilation of the most recent state-of-the-art technology related to Superpave and asphalt pavement design for high volume intersections.

The traffic analysis procedures are based on current methods, which are under review, both nationally and by the Colorado Department of Transportation. If and when traffic projection procedures are modified any such changes will be incorporated into the guide.

As a general guideline, this chapter applies to intersections with greater than three million ESALS. For intersections where traffic is less than three million ESALS, the concepts presented herein are applicable for intersections that have had rutting problems or where rutting is a concern. Normal design criteria, the same used for a regular roadway, as outlined in Chapter Two and Chapter Three will be adequate. **However, intersection with traffic volumes producing ESALS from 1 to 3 million and the traffic makeup is predominately heavy trucks and buses consideration should be given to designing a high performance intersection.** When intersections are going to have traffic volumes over three million ESALS there is a new challenge which must be met.



THE CHALLENGE

Hot mix asphalt (HMA) pavement is the paving material of choice for a majority of Colorado roadways. The advantages of reduced cost and less construction delay combined with improved smoothness and ease of maintenance make asphalt pavement a viable solution for most types of roadways. However, in some cases, good performance of asphalt pavement at high traffic volume intersections has not been achieved.

Some mixes that have a history of good performance may not perform well in intersections, climbing lanes, truck weigh stations and other slow-speed areas. Special attention should be focused on high traffic volume intersections to ensure the same outstanding performance.

The key to achieving this desired performance is recognizing that these pavements may need to be treated differently than conventional roadways. Specifically, the pavement must be designed and constructed to withstand more severe conditions. Well-designed, properly constructed HMA intersections provide an economical, long-lasting pavement with minimal disruption.

This chapter provides design and project scope information so as to improve the performance of asphalt pavement for high traffic volume intersections. Included is guidance on assessing problems with existing intersections, ensuring structural adequacy, selecting and controlling materials, and tips on proper construction practices.

DESIGNING A HIGH PERFORMANCE ASPHALT INTERSECTION

Special consideration needs to be given to intersections with heavy truck traffic and high traffic volumes where 20 year traffic volumes are ≥ 3 million ESALs and where traffic volumes producing ESALs from 1 to 3 million are predominately heavy trucks and buses. A standard pavement design is based on fast moving traffic traveling one direction on long stretches of roadway where drainage is usually easy to handle. With high traffic volume intersections, it's necessary to design for slower stop and go traffic which induces much heavier stresses on the pavement section. Design equivalent single axle loads (ESALs) are greater in intersections because of compounding traffic directions (cross traffic). Also drainage is often compromised within intersections leading to saturation of the pavement section and underlying subgrade.

To avoid performance problems at high traffic volume intersections, the following key strategies should be followed:

- Implementing the correct plan
- Assessing problems with existing intersections
- Ensuring structural accuracy
- Selecting and controlling materials
- Following proper construction practices

IMPLEMENTING THE CORRECT PLAN

Determining whether or not to use a high performance HMA intersection design vs. a conventional HMA design should be assessed on a project-by-project basis. Some general rules to consider are:

- When twenty-year traffic loading is \geq three million ESALs or traffic loadings are between 1 and 3 million ESALs and are from heavy trucks and buses within an intersection, a high performance intersection design should be used.
- If high traffic volume intersections are within one-quarter mile of each other, the entire roadway should be designed using the high performance intersection design.
- Acceleration and deceleration lanes should be included as part of the intersection design.
- Sharp turns with slow moving traffic should be included as part of the intersection design.

If there are not enough high performance intersections within a project to warrant a high traffic volume intersection design throughout, but the intersections that are within the project are potentially subject to the high performance intersection criteria for high volume intersections, they should be blocked out and a high traffic volume intersection design used. This being the case, when there is two-way traffic, the transition should extend at least 300 linear feet on either side of the intersection. If one-way traffic, the transition should be at least 300 linear feet on the deceleration side and 100 linear feet on the acceleration side of the intersection.

ASSESSING PROBLEMS WITH EXISTING INTERSECTIONS

A successful intersection rehabilitation project is dependent on proper project scope. The keys to proper scope are the following:

1. Identifying the problem with the existing intersection,
2. Removing enough of the pavement section to encompass the problem,
3. Designing and reconstructing with a high performance hot mix asphalt mix design especially formulated for high traffic volume intersections.

PERFORMANCE CHARACTERISTICS

The AASHTO Joint Task Force on Rutting (1987) identified four types of rutting:

1. **Mechanical Deformation** (or rutting) is the result of insufficient structural capacity. "Alligator Cracking" usually accompanies it. (Figure 7-1)
2. **Plastic Flow** can result for various reasons:
 - ▶ High Pavement Temperatures
 - ▶ Materials and Mixture Design

Figure 7-1 Rutting in Subgrade

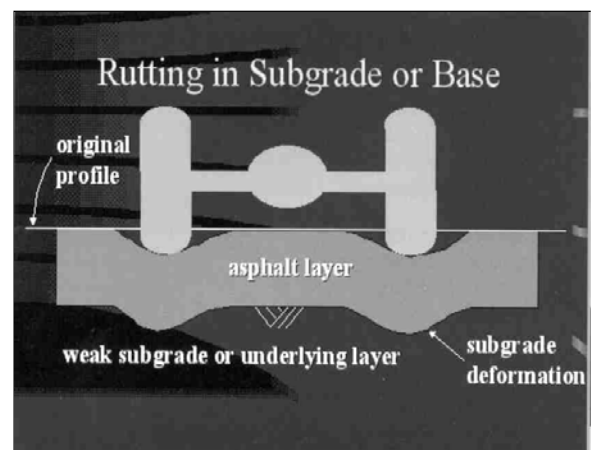

Figure 7-2 Rutting in Asphalt Layer

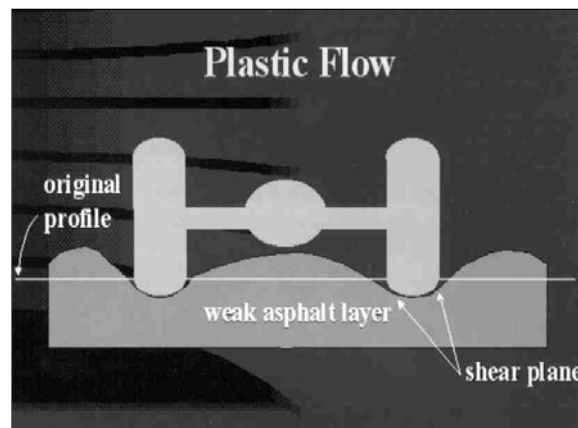
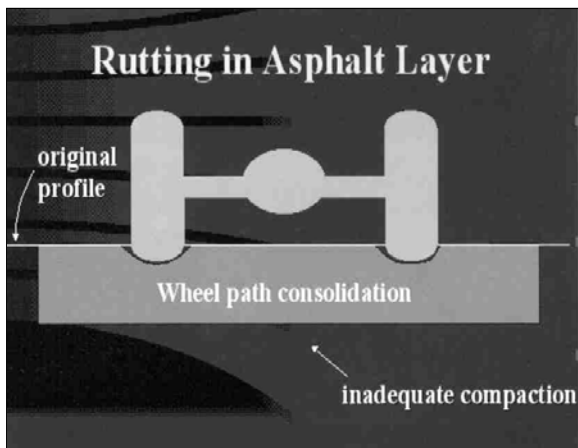

Figure 7-3 Consolidation in the Wheel Path



Rounded aggregate

- Too much binder and/or filler
- Insufficient or too high of VMA

Plastic flow or deformation in the asphalt layer (Figure 7-2) occurs during warm summer months when Pavement temperatures are high. At intersections, stopped and slow moving traffic allows exhaust to elevate asphalt surface temperatures even higher. Dripping engine oil and other vehicle fluids are also concentrated at intersections and tend to soften the asphalt. A properly designed mixture with a stiffer asphalt binder and strong aggregate structure will resist plastic deformation of the HMA pavement.

3. **Consolidation** occurs in the wheel paths because of insufficient compaction of the pavement section. A number of factors can contribute to lack of compaction. (Figure 7-3)
 - ▶ Insufficient compaction effort within the lower base layers of the pavement section
 - ▶ Too few roller passes during paving
 - ▶ Hot Mix Asphalt Material cooling prior to achieving target density
 - ▶ High fluid content (asphalt moisture, dust)
 - ▶ Too low of an asphalt content - lack of cohesion in the mix
 - ▶ Tender Mix - A gradation problem with the mix can make it hard to compact
4. Surface wear is the result of chains and studded tires wearing away the road surface in winter. Moisture damage or raveling will occur if drainage is not adequate.

STRUCTURAL ADEQUACY

To ensure long life performance, the pavement section for intersections must have adequate thickness to support the slow moving or stopped traffic induced loads. Whether new or existing, the thickness of each component of the section must provide structural integrity and be sufficient so that, as a combined unit or pavement section, it will carry the anticipated loads and higher stresses resulting from slower moving traffic.



Key factors to consider when ensuring structural adequacy are:

- ▶ Subgrade strength
- ▶ Frost depth
- ▶ Subbase and base thickness

- ▶ Asphalt thickness
- ▶ Traffic type and loading
- ▶ Drainage

SUBGRADE STRENGTH

For HMA pavement in Colorado the subgrade strength is measured by one of the following methods:

- Colorado Procedure CP-L 3101 ~ ***Strength Determination of Compacted Soils And Aggregates by R-Value***
- ASTM D 1883 – 94 ~ ***Standard Test Method For CBR (California Bearing Ratio) of Laboratory Compacted Soils***
- ASTM D 4429 – 93 ~ ***Standard Test Method For CBR (California Bearing Ratio) of Soils in Place***

Subgrade strength is a function of soil type, density and moisture content. A given soil type with varying density and/or moisture content will perform quite differently in its ability to support the intended pavement section and traffic loads. Laboratory prepared CBR and R-Values are, by standard test procedure, performed at or near optimum moisture contents and compacted densities that reflect man-made fills placed under controlled, closely monitored conditions.

In-place, or in-situ, soils are often much less dense and more saturated. The "true" in-place strength values of the subgrade are often much lower than laboratory measured strength values. Accordingly, ASTM D 4429-93 ***Standard Test Method for CBR (California Bearing Ratio) of Soils in Place*** is recommended as the appropriate method to measure the strength of the in-place subgrade soils.

FROST DEPTH

In Colorado, frost depth needs to be considered when determining pavement thickness. Whenever the frost depth is deeper than the calculated pavement section, and the subgrade soils are susceptible to frost heave, special consideration should be given to the potential effects of the frost. See Chapter Five for discussion on evaluating the effect of frost.

SUBBASE AND BASE THICKNESS

Thickness of subbase and base should be determined based on assigned strength coefficients for each material. Actual thickness determination should be calculated as shown in Chapter Three, Thickness Design. Minimum thickness of an individual base layer should be at least four inches but not less than two times the nominal maximum particle size of the aggregate.

If the underlying subgrade soils are clays and have swell potential, consideration should be given to removing at least two feet of the subgrade and placing a pavement section of subbase, base and HMA. See Chapter Four, Subgrade and Aggregate Base Course Stabilization.

HOT MIX ASPHALT (HMA) THICKNESS

The asphalt thickness should also be determined based on assigned strength coefficients as per the example in Chapter Three. The minimum asphalt thickness of an individual lift of HMA should be at least three times (3x) the maximum nominal particle size of the aggregate in the mix but never less than two inches. The only exception to a two-inch minimum lift thickness would be for surface treatments such as various seal coats, which can vary based on the individual application.



The use of recycled asphalt pavement (RAP) in the pavement section should be considered. However, if it is not convenient to use milled asphalt as RAP in the asphalt mix, it can be incorporated into the subbase and base layers of the pavement section. Milled asphalt mixed with base is stronger than base only. Milled asphalt that is placed as a layer by itself is even stronger. The use of RAP is discussed in more detail in Chapter Twelve.

TRAFFIC TYPE AND LOADING

As discussed in Chapter Two and Chapter Three, up to date, accurate traffic counts of existing traffic and/or realistic traffic projections for future growth and new construction are necessary to ensure that the pavement section is designed properly. **Cross traffic at applicable intersections, needs to be accounted for as part of the traffic count projection.** The percentage of 18,000 pound single axle trucks also needs to be determined.

The impact of construction equipment during early phases of a new subdivision or construction project should be considered. Truck traffic hauling building materials during the development of a subdivision or construction project can have a greater impact on design than past construction or the “built out” condition.

To accommodate the higher stresses on the pavement section in intersections caused by slow moving and stopped traffic, the structural number (SN; Eq. 3-3) determined from the Nomograph in Chapter Three (Figure 3-1) should be increased by a safety factor of 1.25. Thickness of alternate pavement section components should be determined as discussed in Chapter Three.

DRAINAGE

Adequate subsurface and surface drainage is necessary to assure the structural integrity of HMA pavement sections. At intersections, surface drainage is often compromised, leading to ponding of water, which results in early surface deterioration and eventual loss of strength within the pavement section.

In Colorado snow removal can be a problem, especially near intersections. If snow is left piled at the edge of a roadway or street side drainage, curb flow lines, culverts, and cross pans become obstructed, forcing runoff to pond on the paved surface, or worse yet, at the pavement interface with the curb and gutter edge. When this happens, water infiltrates downward saturating the pavement section causing it to lose strength. Maintaining flow lines in ditches, and into drop inlets and culverts is necessary so that water doesn't become concentrated at intersections.

Irrigation of planters and landscape areas often contribute to saturation of the pavement section and subgrade. Such areas should not be irrigated or they should be specially designed with subdrains and edge drains to keep water out of the pavement section.

SELECTING AND CONTROLLING MATERIALS

The key elements of a properly designed intersection include various combinations of quality materials. Those components are as follows and are discussed in the following sections.

- Modified subgrade
- Geosynthetic fabrics and mats
- Aggregate subbase
- Aggregate base
- Drainage systems
- Recycled construction materials
- Hot Mix Asphalt

Modified Subgrade

Subgrade modification (Chapter Four) techniques to improve the strength of the subgrade are often beneficial and recommended in special cases. Depending on the subgrade soil type; lime, fly ash, and cement are types of materials used to modify and stabilize subgrade soils. A qualified geotechnical consultant should be retained to help with a potential subgrade modification design.

Geosynthetic Fabrics and Mats

Geosynthetic fabrics and mats (Chapter Six) can be used as reinforcement in a variety of ways within and below the pavement section. Any time poor or marginally acceptable in-situ soils are encountered, geosynthetic fabrics and mats should be considered. Technical representatives for individual brand materials are available to help in the selection of the most appropriate product.

Separation fabrics used to separate fine grain silts and clays from open-graded drainage mats and subbase/base materials are an especially valuable and are a cost effective application. Without them, a soft subgrade could inundate the more open void spaces of drainage mats and base courses thereby decreasing their strength and ability to drain.

Aggregate Subbase

Aggregate Subbase courses should conform to Section 304 "Aggregate Base Course" and section 703.03 "Aggregate for Bases" Class 1 or 2 of the ***Colorado Department of Transportation Standard Specifications for Road and Bridge Construction, 2005 Edition.***

Aggregate Base

Aggregate Base Course should conform to section 304 "Aggregate Base Course" and Section 703.03 "Aggregate for Bases" Class 6 of the ***Colorado Department of Transportation Standard Specifications for Road and Bridge Construction, 2005 Edition.***

Drainage Systems

A well drained pavement section is required to maintain the strength coefficients assigned to individual components of a hot mix asphalt pavement section. Edge drains, cross drains, and drainage layers should tie into a collection system or some of means to carry collected water away from intersections and the pavement section. Installing drainage systems that collect and impound water rather than diverting it away from the pavement section should never be allowed.

Recycled Construction Materials

During rehabilitation of intersections it is often a cost savings to utilize certain construction materials that have been removed by placing these materials back into the pavement section. Such things as pulverized concrete, milled asphalt, and existing bases can sometimes be re-incorporated into subbase and base layers with or without additional enhancement. Doing so can result in a cost savings, for the project without sacrificing the structural integrity of the pavement section. Any such inclusion of these materials should be based on assigning appropriate strength coefficients for their individual use. Chapter Twelve is devoted to the use of recycled asphalt materials.

HMA PAVEMENT SECTION DESIGN

The design of the HMA pavement should follow the above discussion and the procedures in Chapters Two and Three. The design consideration and pavement structure design is the same for a high performance intersection as the roadway leading to the intersection with the exception that cross traffic volumes need to be taken into account when determining the traffic ESALs. Intersections should be designed using Superpave mix design procedures and performance grade asphalt binders.

CONSTRUCTION PRACTICES

A final and very important strategy to consider when rehabilitating or constructing a high performance intersection is following proper construction practices. The quality of a completed project is not only dependent on proper design and good quality materials, but also on using quality workmanship. Here are several issues to address to ensure quality workmanship.

- Process Control Plan
- Compliance with Project Specifications
- Utilities
- Production and Placement



PROCESS CONTROL PLAN

When rehabilitating intersections or constructing new intersections, special consideration should be given to details and to practicing proper construction techniques. A "Process Control Plan" should be submitted by the contractor. Details of construction, including control of materials and their transportation and placement need to be covered. A complete schedule of construction activities should be included. Process Control, Acceptance, and Quality Assurance testing should be defined and coordinated so that the parties work together for the benefit of the project.

COMPLIANCE WITH PROJECT SPECIFICATIONS

Materials to be used in the intersection construction project should be sampled and tested before placement to make sure they are of high quality and in compliance with project specifications. Additional sampling and testing should be performed again during placement and upon completion of each phase to ensure that they are still in compliance and have been placed or installed properly. Special attention should be given to controlling grade and slope for each portion of the pavement section. Target densities should be met for the various materials provided.

UTILITIES

Whether it be intersection rehabilitation or new construction, a utility study should be performed to determine if utilities being proposed or that are already installed are adequate in size to handle the projected growth within their service area. It should be verified that they are adequately sized and that they have been installed properly, and that utility trenches have been backfilled and compacted properly.

PRODUCTION AND PLACEMENT

At the start of paving, the volumetric properties of the plant produced material should be re-evaluated. Adjustments should be made to the plant produced material as necessary, so that the volumetric criteria remain within the specification limits required for the Job Mix Formula (Mix Design). If "fine tuning" of the plant produced mix does not allow for the required volumetric properties, a new Job Mix Formula should be required.

During Hot Mix Asphalt paving, it is vital that the contractor practice, at a minimum, the following proper construction techniques and pay attention to details:

- Avoid the use of diesel fuel in truck beds.
- Do not overheat the mixture.
- Thoroughly clean milled areas.
- Avoid segregation during production, transportation and placement.
- Ensure proper joint construction to prevent the entrance of water into the structure.
- Achieve target density.

CONCLUSION

Even with ever increasing truck traffic and traffic levels, tools now exist to gain top performance from HMA intersections. Well-designed, properly constructed HMA intersections provide an economical, long lasting pavement with minimal disruption. Implementation of an *intersection strategy* as outlined in this chapter will result in a dramatic increase in the performance life of the pavement, reducing life cycle costs.

CAPA Has developed a separate document "***A Guideline for the Designing High Performance Asphalt Intersections for Colorado Roadways***".

This document is available as part of the Asphalt Technical Resources CD, 2006.

CHAPTER EIGHT

PARKING LOT

DESIGN

CHAPTER EIGHT

PARKING LOT DESIGN

GENERAL CONSIDERATIONS

The parking lot is the first - and the last - part of a building complex to be viewed by the user. It is the gateway through which customers, visitors, and employees pass. This first impression is very important to the overall feeling and atmosphere conveyed to the user.

Developers want their new facilities to be attractive, well designed, and functional. Though many hours are spent on producing aesthetically pleasing building designs, the same design consideration for the parking area is often overlooked. Pavements in parking areas that are initially under-designed can experience excessive maintenance problems and a shortened service life.

When properly designed and constructed, parking areas can be an attractive part of the facility that is also safe, and most important, usable to the maximum degree. In addition, parking areas should be designed for low maintenance costs and easy modification for changes in use patterns.

The information in this chapter will provide a general guide to proper parking area design, construction, and facility layout.

GENERAL PLANNING

In developing the parking area plan, several important details should be considered. First and foremost in the mind of the developer may be providing the maximum parking capacity in the available space while ensuring convenience and safety. On the other hand, the user will be concerned about sidewalk traffic flow, pedestrian visibility, obstructions and signs. Consideration must also be given to handicap parking. Areas need to be set aside, also, for bicycle and motorcycle parking.

Criteria has been developed for optimizing parking area space. Among these are the following: Use rectangular areas where possible. Make the long sides of the parking areas parallel. Design so that parking stalls are located along the lot's perimeter.

Use traffic lanes that serve two rows of stalls. Special attention should be given to the flow of traffic in and out of the parking lot as well as circulating routes inside the parking lot. Keep entrances far away from busy street intersections and from lines of vehicles stopped at a signal or stop sign. Be sure that the entering vehicles can move into the lot on an internal aisle, thereby avoiding entering congestion caused by involvement with turning vehicles. A



pedestrian traffic-flow study is important to provide information about both safety and convenience.

Parking lot markings are a very important element of a good parking lot. The parking area should be clearly marked to designate parking spaces and to direct traffic flow. As specified in the *Manual on Uniform Traffic Control Devices (MUTCD)*, parking on public streets should be marked out by using white traffic paint, except for dangerous areas, which should be marked in yellow. However, yellow lines are commonly used in off-street parking lots. Pavement striping should be four inches in width.

New asphalt surfaces can be marked with either traffic paint or cold-applied marking tape. For best results with paint application, allow the Hot Mix Asphalt (HMA) to cure for several days.

CONSTRUCTION PRACTICES

- **Drainage Provisions** ~ Drainage problems are frequently a major cause of parking area pavement failures. This is especially the case with irrigation sprinkler systems located in parking lot islands and medians. It is critical to keep water away from the subgrade soil. If the subgrade becomes saturated, it will lose strength and stability, making the overlying pavement structure susceptible to breakup under imposed loads.

Drainage provisions should be carefully designed and should be installed early in the construction process. **Parking area surfaces should have a minimum slope of 2 percent (2%) or 1/4 inch per foot.** Pavement cross slopes of less than 2 percent are hard to construct without the formation of “bird bath”, slight depressions that pond water. They should be constructed so water does not accumulate at the pavement edge. Areas of high natural permeability may require an underdrain system to carry water away from the pavement substructure. Any soft or spongy area encountered during construction should be immediately evaluated for underdrain installation or for removal and replacement with suitable materials.

The use of HMA base (compared to use of untreated aggregate base) will greatly reduce the potential for problems related to water strength and stability.

- **Subgrade Preparations** ~ Underground utilities should be protected or relocated before grading. Topsoil should be removed. Low-quality soil may be improved by adding granular materials, lime, asphalt, or other mixtures. Laboratory tests are recommended to evaluate the load-supporting characteristics of the subgrade soil. However, designs are sometimes selected after careful field evaluations based on experience and knowledge of local soil conditions.

The area to be paved should have the rock, debris, and vegetation removed. The area should be treated with a soil sterilant to inhibit future vegetative growth. Grading and compaction of the area should be completed so as to eliminate yielding or pumping of the soil.

The subgrade should be compacted to a uniform density of 95 percent of the maximum density. This should be determined in accordance with Standard or Modified Proctor density (ASTM D698 or ASTM D 1557) as appropriate to the soil type. When finished, the graded subgrade should not deviate from the required grade and cross section by more than one half inch in ten feet. If the subgrade is a fine-grained silt or clay, a separation fabric should be considered for use to prevent the finer material in the subgrade from inundating the mere open-graded layers

to be placed as a part of the pavement section.

- **Untreated Aggregate Base Construction** ~ The untreated aggregate base course should consist of one or more layers placed directly on the prepared subgrade (with or without a separation fabric depending on soil type). It should be spread and compacted with moisture control to the uniform thickness, density and finished grade as required on the plans. The minimum thickness of untreated aggregate base course is four inches. The aggregate material should be of a type approved and suitable for this kind of application.

It should be noted that an untreated aggregate base might be sensitive to water in the subgrade. Pavement failures associated with water in the subgrade are accelerated if an untreated base allows water to enter the pavement structure. Grading should be done to promote natural drainage or other types of under drain systems should be included in the design.

- **Prime Coat** ~ An application of low viscosity liquid asphalt may be required over untreated aggregate base before placing the HMA surface course. A prime coat and its benefits differ with each application, and its use often can be eliminated. Discuss requirements with the paving contractor.

- **Hot Mix Asphalt (HMA) Base Construction** ~ The asphalt base course material should be placed directly on the prepared subgrade in one or more lifts. It should be spread and compacted to the thickness indicated on the plans. Compaction of this asphalt base is one of the most important construction operations contributing to the proper performance of the completed pavement. This is why it is so important to have a properly prepared and unyielding subgrade against which to compact. The HMA base material should meet the specifications for the mix type specified.

- **Tack Coat** ~ Before placing successive pavement layers, the previous course should be cleaned and a tack coat of diluted emulsified asphalt should be applied if needed. The tack coat may be eliminated if the previous coat is freshly placed and thoroughly clean.

- **Hot Mix Asphalt (HMA) Surface Course** ~ Material for the surface course should be an HMA mix placed in one or more lifts to the finished lines and grade as shown on the plans. The plant mix material should conform to specifications for hot mix asphalt.

The HMA surface should not vary from established grade by more than one-quarter inch in ten feet when measured in any direction. Any irregularities in the surface of the pavement course should be corrected directly behind the paver. As soon as the material can be compacted without displacement, rolling and compaction should start and should continue until the surface is thoroughly compacted and roller marks disappear.

THICKNESS DESIGN FOR PARKING LOTS

The thickness of the asphalt pavement section for parking lots should be determined using the information already presented in Chapters Two and Three of this design guide. Table 8-1 shows suggested thicknesses for HMA pavement, full depth HMA design and also with aggregate base course, for various subgrade CBR values and traffic levels. It is recommended that a qualified design consultant be used to design the pavement structure and layout of the parking lot. The design consultant can design the pavement structure using the methods discussed in Chapters Two and Three which would provide for the most economical pavement structural section.

Table 8-1
Suggested Thickness Design - Parking Lots

Traffic Level	ESALs	Subgrade Class			
		Poor CBR \leq 5 R \leq 28	Fair CBR 6-9 R 33- 41	Good CBR 10-19 R 43-52	Excellent CBR \geq 20 R \geq 53
Hot Mix Asphalt over Aggregate Base Course, Inches					
Light (Passenger Cars)	Up to 10,000 ESALs	2.5/13.0	2.5/8.5	2.5/6.0	2.5/4.0
	10-50,000 ESALs	3.5/16.0	3.5/11.0	3.5/6.0	3.5/6.0
Moderate (Passenger Car and Light Trucks)	50-100,000 ESALs	4.0/17.0	4.0/12.0	4.0/6.0	4.0/6.0
	100-250,000 ESALs	5.0/18.0	4.5/13.0	4.5/6.0	4.5/6.0
Heavy (Heavy Industrial)	250-500,000 ESALs	5.5/12.0	5.5/9.5	5.5/6.5	5.5/6.0
	500-1,000,000 ESALs	6.0/23.0	6.0/15.5	6.0/7.0	6.0/6.0
Full Depth Hot Mix Asphalt, Inches ³					
Light	Up to 10,000 ESALs	6.0	5.0	4.0	4.0
	10-50,000 ESALs	7.5	5.5	4.5	4.0
Moderate	50-100,000 ESALs	8.0	7.0	5.5	4.5
	100-250,000 ESALs	9.0	7.5	6.0	5.5
Heavy	250-500,000 ESALs	10.5	8.5	7.0	6.0
	500-1,000,000 ESALs	11.5	9.5	7.5	6.5
1.inch = 25 mm					
2. Excellent subgrade conditions are ideal for full depth asphalt; however, a minimum of 100 mm (4 inches) of HMA is recommended. In some cases, aggregate is needed to provide material to fine grade and to provide a smooth surface to pave on. If needed, 100 mm (4 inches) of aggregate is recommended as a minimum thickness for this purpose.					
3. Full depth asphalt can be built on poor and fair soils only in dry conditions and when the subgrade soils may be brought up to optimum moisture conditions and compacted to specification density.					

Special truck lanes are sometimes required to expedite traffic to loading areas, trash dumpster sites, and equipment areas. Design thicknesses for these lanes or pavement areas should be increased to accommodate the expected ESALs (heavy trucks). If a parking lot is small and has low traffic volume but has the weekly or bi-weekly trash truck, it would be more economical to construct the entire parking lot to handle the truck traffic than it would be to construct a heavy traffic lane just for trucks. A lot not constructed to handle heavy trucks will cost more in the long run because of continuing repairs to the pavement being destroyed by heavy trucks .

PLANNED STAGE CONSTRUCTION

Planned stage construction is a means of providing fully adequate pavements with the effective use of funds, materials, and energy. As defined, it is the construction of an HMA parking lot or roadway in two or more stages, separated by a predetermined interval of time. In many situations, building pavements by stages makes good economical sense. It is a technique long used by city and highway engineers.

Stage Construction is **not** maintenance. It is the placement of a minimum depth of pavement during initial construction, and a final surface course placed at a planned future date. HMA paving lends itself to this kind of construction.



As an example, for financial reasons, the owner of a new department store with a 350 space car parking lot decides to stage construct the six and one half inch, full-depth asphalt parking lot. Stage 1 is constructed at the time the store is built. A total depth of five inches of HMA is placed. Stage Two, consisting of the final surface course of one and one half inch, will be placed at a set time in the future. Consideration must be given to the nominal maximum size aggregate in the mix. The final lift thickness should be that which can be laid and compacted as discussed in Chapter Five. The truck loading zone and the dumpster-area are paved the

full depth during initial construction.

Staged construction has the advantage of providing a thoroughly adequate, all weather pavement for the initial development of an area. Any damage to the Stage 1 pavement caused by traffic, settlements, or utility tear-ups can be repaired prior to placement of the final surface. With a proper asphalt tack coat where needed, the Stage 2 pavement bonds to the old surface and becomes an integral part of the entire pavement structure.

Another items of caution is if stage is planned and there are curb and gutter sections, drainage will become a problem. Not all the water from the lower paved area will be able to get into the drainage system. A means for the water to get into the drainage system will have to be constructed. Also, if asphalt curbs are used they are usually constructed on the paved surfaced. Careful planning is a must if stage construction is going to be used.

HOT MIX ASPHALT (HMA) CURB

Asphalt curbs have become increasingly popular as accessories to paving because they are:

- economical and easy to construct
- can be built much faster than other types
- aren't affected by ice-and snow-melting chemicals
- Able to be laid on an existing pavement using a slip form paver.

Many parking facilities have some form of curbing around the perimeter for both functional and aesthetic reasons. The curbs control drainage, delineate the pavement edge, prevent vehicular encroachment on adjacent areas, and enhances the esthetics of the parking lot. A typical HMA curb cross section is shown in Figure 8-1.

The bitumen content and gradation should be modified as necessary to produce a suitable mixture for HMA curb construction. Curb mixes that are proportioned using aggregate mixture sizes of three eighths ($\frac{3}{8}$ "") or one half inch ($\frac{1}{2}$ "") have proven to be most satisfactory and are recommended for curb construction in Colorado.

CURB CONSTRUCTION

Before curb construction begins, the placement area should be cleaned thoroughly. A tack coat should be applied to the pavement surface at a maximum rate of 0.10 gallons per square yard.

The HMA curb should be laid true to the specified line, profile, and cross section with an approved self-propelled curb-laying machine. The mixture should be fed to the hopper of the machine directly from the truck with a chute, conveyor, or by shoveling into the hopper.

HMA curbs should be backed with earth fill or by constructing a double line of curb and filling the median with compacted asphalt mix. A typical HMA cross-section is shown in Figure 8-3.

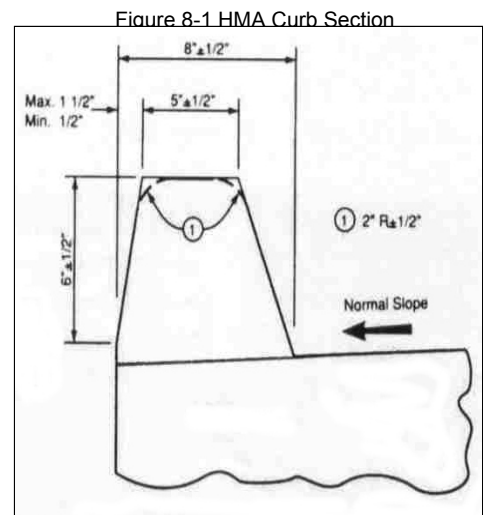

ASPHALT MAT-PLATFORM FOR BUILDING CONSTRUCTION AND SITE PAVING

Site paving is the recommended first step in many types of building construction projects. It offers several advantages as a working mat or platform before building construction begins for shopping centers, schools, manufacturing concerns, warehouses, and similar facilities.

In this technique, an HMA base course is constructed on a prepared subgrade over the entire area that will become the parking areas, service roadways, and buildings. When building construction is completed, a final HMA surface course is placed on the asphalt base.

ADVANTAGES

Paving a building site before construction is completed has several benefits. These include the following:

1. It ensures constant accessibility and provides a firm platform upon which people and machines can operate efficiently, speeding construction.
2. It provides a dry, mud-free area for construction offices, materials storage, and worker parking, eliminating dust-control expenditures.

3. It eliminates the need for costly select material - the asphalt subfloor ensures a floor slab that is dry and waterproof.
4. Steel-erection costs can be reduced because a smooth, unyielding surface results in greater mobility for cranes and hoists.
5. The engineer can set nails in the asphalt pavement as vertical and horizontal control points, effectively avoiding the risk of loss or disturbance of this necessary survey work.
6. Excavation for footings and foundations and trenching for grade beams can be accomplished without regard for the asphalt base.

CONSTRUCTION PRACTICES

The construction of an asphalt mat-platform for building construction and site paving would be the same as for a parking lot. Therefore you are referred to the section under Construction Practices beginning on page 8 - 2.

CAPA Has developed a separate document "A Guideline for the Design and Construction of Asphalt Parking Lots in Colorado".

This document is available as part of the Asphalt Technical Resources CD, 2006.

CHAPTER NINE

DESIGNS FOR RECREATIONAL USES

CHAPTER NINE

DESIGNS FOR RECREATIONAL USES

HOT MIX ASPHALT (HMA) PAVEMENTS FOR NON-VEHICULAR USE

In addition to highways, streets, and parking lots that carry autos and trucks, many other applications for asphalt pavements exist. Sidewalks, bicycle and golf cart paths, playground areas, tennis courts, and site paving are some common applications. In many cases, the primary design consideration is a pavement structure capable of supporting occasional maintenance and emergency vehicles and resisting freeze-thaw cycles. Therefore, a minimum thickness to accommodate these loads is a basis for the thickness design.

A good reference for trails and paths in the "Guideline for the Design and Construction of Asphalt Pavements for Colorado Trails and Paths". This guide provides guidelines for designing and constructing asphalt paths and trails in Colorado. It covers cost comparisons for path constructed of various materials, pavement thickness, mix design, and construction and maintenance criteria. The guide can be obtained from the Colorado Asphalt Pavement Association.

BIKEWAYS, GOLF CART PATHS, RECREATION TRAILS, AND WALKWAYS

It is desirable to blend this type of pathway into the contours of the existing ground to preserve aesthetics and to reduce the impact on the natural environment. Surface drainage should flow away from these pathways wherever possible.

Because of the variety of designs and applications, individual pathway widths are not listed here. For bikeway and golf cart paths in particular, the size and availability of conventional road construction and maintenance equipment may determine width. Generally, a minimum width of eight feet is recommended; however, a twelve-foot width may be cost effective. As a safety measure, additional widening on sharp curves is recommended.

Recreation trails and walkways are usually paved to an **eight foot width** to accommodate construction and maintenance operations and to provide access for emergency vehicles. It may be desirable to pave a walkway in an urban environment only four feet wide (or wider if significant numbers of pedestrians are present). These pavements usually are not designed to withstand repeated loads from

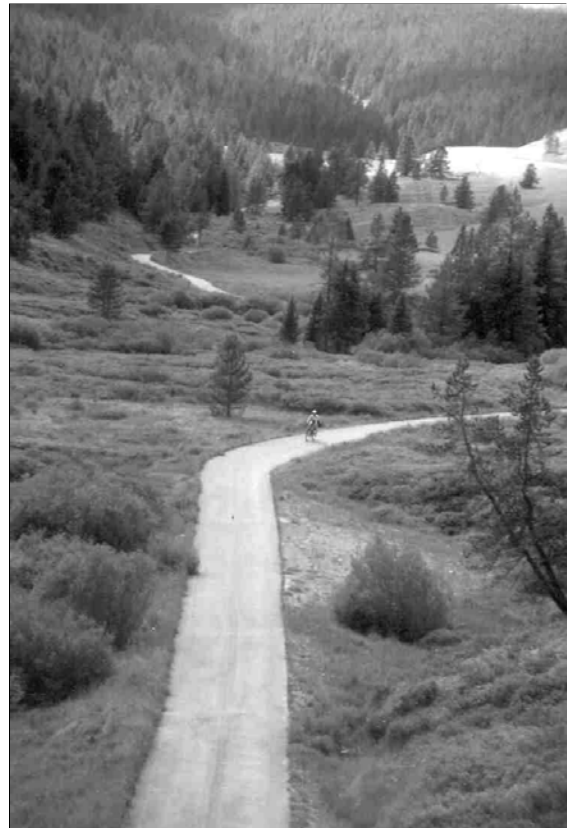

maintenance or emergency vehicles, but an occasional heavy-load application can be made without damage.

CONSTRUCTION PRACTICES

DRAINAGE

It is very important to keep water away from the subgrade soil. If the soil becomes saturated, it will lose strength and stability, making the overlying pavement structure susceptible to breakup under imposed loads. Both surface and subsurface drainage should be considered. Drainage should be carefully designed and should be installed as early in the construction process as practical.

SUBGRADE PREPARATION

Because the subgrade must serve both as the working platform to support construction equipment and as the foundation for the pavement structure, it is vital to ensure that the subgrade is properly graded to the lines and grades shown on the plans and compacted to the specified density. If the subgrade soils are susceptible to swelling, this should be remedied prior to the placing of any base material or surface paving material. Swelling soils will produce cracking of the asphalt surface within a short period of time. Utilities should be protected or relocated before grading. Drainage structures should be completed with the grading. Top soil, debris, vegetation, and rocks should be removed prior to subgrade preparation. After the subgrade has been prepared a soil sterilant should be applied to inhibit future vegetative growth. The sterilant should be applied in accordance with the manufacturers' recommendation. Inappropriate application of the sterilant can destroy the adjacent environment to the pathway.

HOT MIX ASPHALT (HMA) PAVEMENTS



Bicycle, golf cart paths, recreational trails, and sidewalks may be constructed in one course or with a separate base and surface course.

The HMA base course should be placed directly on the prepared subgrade in one lift in a thickness of four inches or less (uncompacted thickness), and spread and compacted. Compaction is one of the most important construction operations in terms of its contribution to the performance of the completed pavement.

If a compacted aggregate base is proposed, place it on the prepared subgrade and compact it to ensure a hard, uniform, well compacted surface.

The surface course, or the full-depth HMA base course, should be placed to the true line and grade as shown on the plans. If placing multi-layers of such a base course and HMA paving the layers should be placed to their respective line and grade. Any irregularities in the surface of this course should be corrected directly behind the paver. Rolling and compaction should be started directly behind the paver and should continue until the surface is compacted to the density specified. Roller marks should be removed without over rolling.

Before placing successive layers, the previous course should be clean. If necessary, a tack coat of diluted emulsified asphalt may be applied.

PAVEMENT MARKINGS

Pavement markings for bicycle paths are covered in the **MUTCD** under Part XI. Markings are especially important when the designated bicycle lane is to be accommodated on a roadway shared with motorists.

PAVEMENT THICKNESS

The pavement thickness of Hot Mix Asphalt (HMA) for bikeways, golf cart paths, recreational trails, and walkways should be in accordance with the values shown in Table 9-1.

Table 9-1
Thickness Chart: Bikeways, Paths, Trails, and Walkways

Subgrade Type			
Class CBR	Poor 3	Moderate 6	Good 9
Full Depth HMA Pavement - inches			
Base	3.0	2.5	2.0
Surface	2.0	2.0	2.0
Total	5.0	4.5	4.0
HMA Pavement with Untreated Aggregate Base			
Untreated Aggregate Base	6.0	4.0	4.0
Surface	3.0	3.0	2.5
Total	9.0	7.0	6.5
Note: Traffic for the thicknesses is Class I, see discussion in Chapter 2.			

If the designer has more accurate data than presented in the above table, knowing equivalent ESALs and soil strengths (CBR or R-value), the pavement structure can be design using the procedure outlined in Chapter Three.

RECREATIONAL AREAS

The following information and design guidance cover the basic components of building durable, economical asphalt playgrounds.

BASKETBALL COURTS

A common section of the playground or recreational area is the basketball court. The following information and design guidance cover the basic components of building basketball courts. General guidelines for court layout and dimensions are included. Because individual designs are based on intended uses and available funds, dimensions and suggested layouts are not included here.

Court Layout

The basic layout of a basketball court is shown in Figure 9-1.

Figure 9-1 Typical Basketball Court Layout

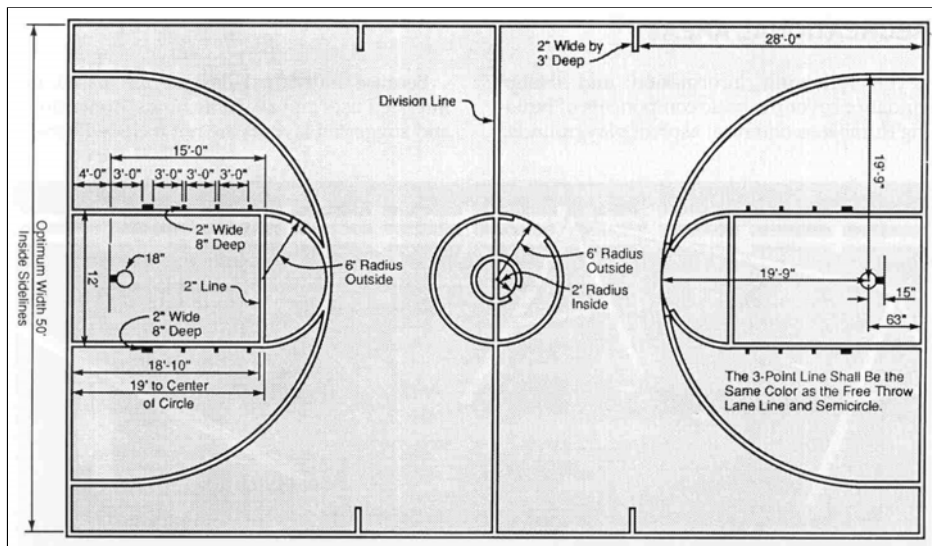

An unobstructed space of at least three feet outside the end lines and sidelines is required. This space would preferably be ten feet wide. End lines, sidelines, and other court line markings, except neutral zone markers, should be a minimum of two inches wide.

These pavements usually are not designed to withstand repeated loads from heavy maintenance or emergency vehicles, but an occasional load application can be made without damage.

CONSTRUCTION PRACTICES

Construction practices used for building a basketball court are the same as they would be for constructing a recreational trail, walkways, bikeways and golf cart paths. Therefore, you are referred to the section on Construction Practices for Bikeways, Golf Cart Paths, Recreational Trails and Walkways in this chapter.

HMA THICKNESS

Subgrade Type			
Class CBR	Poor	Moderate	Good
Full Depth HMA Pavement – inches			
Base	3.0	2.5	2.0
Surface	2.0	2.0	2.0
Total	5.0	4.5	4.0
HMA Pavement with Untreated Aggregate Base			
Untreated Aggregate Base	6.0	4.0	4.0
Surface	3.0	3.0	2.5
Total	9.0	7.0	6.5

Note: Traffic for the thicknesses is Class I, see discussion in Chapter 2.



The HMA thickness for playgrounds and courts should be in accordance with the values shown in Table 9-2. However, if the designer has more accurate data than presented in the above table, knowing equivalent ESALs and soil strengths (CBR or R-value), the pavement structure can be design using the procedure outlined in Chapter Three.

TENNIS COURTS

The following information and design guidance cover the basic components of building durable, economical asphalt pavements for tennis courts. General guidelines for the layout and dimensions are included. These pavements usually are not designed to withstand repeated loads from heavy maintenance or emergency vehicles, but an occasional load application can be made without damage.

Figure 9-2 Typical Tennis Court Layout

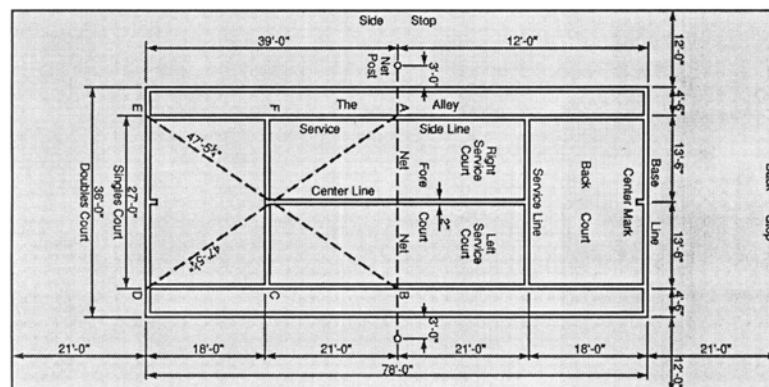

COURT LAYOUT

The basic layout and dimensions of a tennis court are illustrated in the following figure. The tennis court layout will help the engineer prepare an estimate of quantities required for such facilities. An edging of brick, concrete, steel, or landscaping stone should be installed around the entire perimeter of the court area. Top elevation of the edging should be one half of an inch below the finished grade level, and the court's surface should be tapered from six inches from the edge to meet it.



CONSTRUCTION PRACTICES

Construction practices used for building a basketball court are the same as they would be for constructing a recreational trail, walkways, bikeways and golf cart paths. Therefore, you are referred to the section on Construction Practices for Bikeways, Golf Cart Paths, Recreational Trails and Walkways in this chapter.

TENNIS COURT OVERLAYS

There are many reasons for overlaying an existing tennis court. For example, it may have a badly oxidized or aged surface, poor drainage, or a poorly constructed base. Each of these conditions and their severity should be considered in determining the required overlay pavement thickness.

Many items should be considered when determining the most sound and economical procedures to follow in resurfacing a tennis court. Therefore, it is strongly recommended that a qualified asphalt paving contractor, one experienced in tennis court construction, be consulted.

PAVEMENT THICKNESS

The pavement thickness for tennis courts should be the same as for playgrounds and basketball courts as shown in Table 9-2 or determined by using the procedures in Chapter Three.

ASPHALT-RUBBER RUNNING TRACKS

High schools and colleges are increasing the demand for outdoor and indoor asphalt-rubber running tracks and runways for long jump, high jump, and pole vault. For information on track size, number of lanes, and other features, refer to the Amateur Athletic Union, NCAA or other official specifications.

CONSTRUCTION PRACTICES

Construction practices for running tracks would be the same for as for other recreational use facilities. Please refer to Construction Practices for Bikeways, Golf Cart Paths, Recreational Trails and Walkways in this chapter.**Asphalt-Rubber Surface Construction**

Several manufacturers supply rubber material for use in asphalt-rubber surface mixes. Obtaining advice from these companies is suggested.

If an asphalt-rubber mix proves to be uneconomical or impractical, an alternative recommendation would be to specify an asphalt sand mix.

The surface course material should be placed on the previously constructed base, spread, and compacted to the required thickness and density as specified and in the grades and dimensions shown on the plans. A minimum thickness of one inch is recommended.

The finished surface should not deviate more than 1/4 inch when measured with a 10-foot straight edge.

Tack Coat

A tack or bond coat of CSS-1, SS-1, SS-1h, or an approved alternative should be applied at the rate of 0.02 to 0.05 gallons per square yard between each course. The surface should be cleaned of dust, dirt, or other loose material before the bond coat is applied. If emulsion is used, it should be diluted with equal parts of water or as specified in the proposal.

CAPA Has developed a separate document "A Guideline for the Design and Construction of Asphalt Pavements for Colorado Trails and Paths".

This document is available as part of the Asphalt Technical Resources CD, 2006.

CHAPTER TEN

LIFE CYCLE

COST ANALYSIS

CHAPTER TEN

LIFE CYCLE COST ANALYSIS

Introduction

Not all investments are equal; and because road and airfield pavements are usually constructed and maintained from public funds (raised by taxes or by borrowing), it seems sensible that the economics of alternative pavement materials should be examined carefully and should be part of the pavement design process.

Presently, many state highway agencies conduct pavement life cycle costing analyses using alternative materials. Unfortunately, the procedures are not uniform. In some instances the agencies refuse to divulge the input parameters making it very difficult to check whether or not public funds are being expended wisely in selecting construction materials. One of the reasons highway agencies may be reluctant to provide details of their life cycle costing analyses is that they may lack confidence in their maintenance data. Strange as it may seem in this computer age, reliable maintenance cost data are the exception rather than the rule. Another reason that highway agencies are reluctant to define maintenance service levels is the fear that written guides may be used against them in tort liability cases.

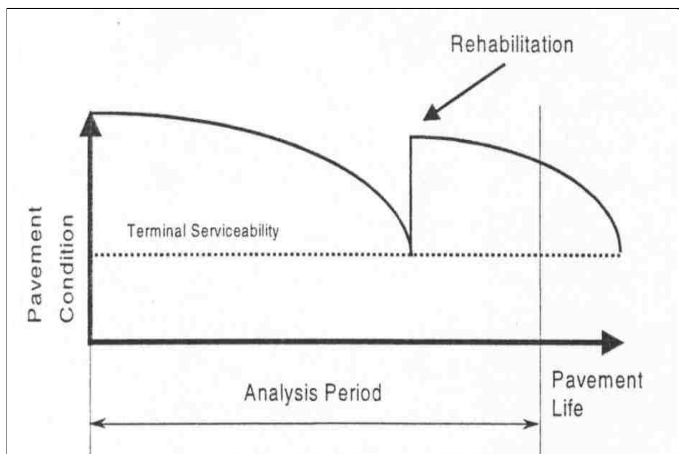

Life Cycle Cost Analysis (LCCA) is an analysis technique that builds on the well-founded principles of economic analysis to evaluate the **overall long term economic efficiency** between competing alternative investment options. It does not address equity issues. It incorporates initial and discounted future agency, user, and other relevant costs over the life of alternative investments. It attempts to identify the best value (the lowest long-term cost that satisfies the performance objective being

sought) for investment expenditures.

Design Options

The Life Cycle Cost ANALYSIS (LCCA) should be conducted as early in the project development cycle as possible. For pavement design, the appropriate time for conducting the LCCA is during the project design stage. The LCCA level of detail should be consistent with the level of investment. Typical LCCA models based on primary pavement management strategies can be used to reduce unnecessarily repetitive analyses.

LCCA need only consider differential cost among alternatives. Costs common to the alternatives cancel out and are not included in LCCA calculations. Inclusion of the potential LCCA factors in every analysis is counterproductive; however, LCCA factors and assumptions should be addressed, even if only limited to an explanation of the rationale for not including eliminated factors in detail. Sunk costs, which are irrelevant to the decision at hand, should not be included.

There are many design options open to the pavement design engineer. The choices of structural materials include: flexible, rigid, or composite, i.e. asphalt (either full depth or with unbound granular layers in the structure below the asphalt layer/layers), pcc (Portland cement concrete), or a combination of flexible and pcc (typically an asphalt surface with a cement bound base). Designers can plan for a stage construction approach in which the structural strength of the pavement is increased from time to time according to growth in traffic. The designer can also plan for a high initial cost pavement which, it is assumed, will require little maintenance for a lengthy period.

While such choices may be structurally equivalent over the analysis period considered, the choices are unlikely to be equivalent from the economic standpoint. Because the costs of constructing and maintaining pavements occur at different times over the analysis period, the cost streams in these different years must be adjusted to the same base before total costs can be assessed. This can be accomplished by using the Present Worth of Costs or Net Present Value technique.

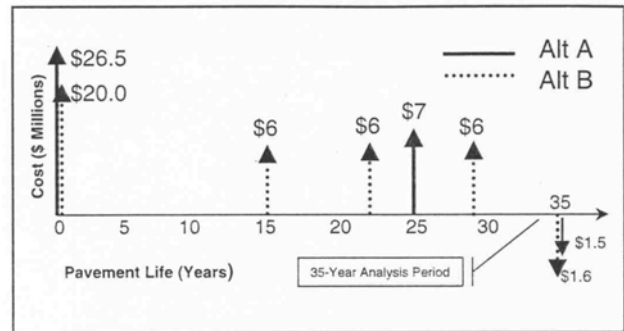

LCCA PRINCIPLES OF GOOD PRACTICE

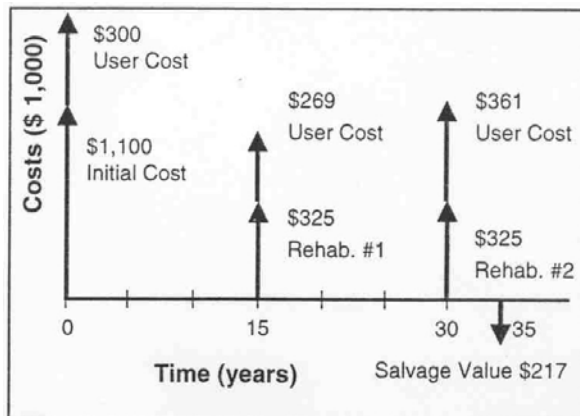

The LCCA analysis period, or the time horizon over which alternatives are evaluated, should be sufficient to reflect long-term cost differences associated with reasonable design strategies. While FHWA's LCCA Policy Statement recommends an analysis period of *at least* 35 years for all pavement projects, including new or total reconstruction projects as well as rehabilitation, restoration, and resurfacing projects, an analysis period range of 30 to 40 years is not unreasonable.

Net Present Value (NPV) is the economic efficiency indicator of choice. The Uniform Equivalent Annual Cost (UEAC) indicator is also acceptable, but should be derived from NPV. Computation of Benefit/Cost (*B/C*) ratios is generally not recommended because of the difficulty in sorting out cost and benefits for use in the *B/C* ratios.

Future cost and benefit streams should be estimated in constant dollars and discounted to the present using a real discount rate. Although nominal dollars can be used with nominal discount rates, use of real/constant dollars and real discount rates eliminates the need to estimate and include an inflation premium. In any given LCCA, real/constant or nominal dollars must **not** be mixed (i.e., costs must be in real dollars or costs must be in nominal dollars). Further, the discount rate selected must be consistent with the dollar type used (i.e., use real cost and real discount rates or nominal cost and nominal discount rates) .

The discount rates employed in LCCA should reflect historical trends over long periods of time. Although long-term trends for real discount rates hover around 4 percent, 3 to 5 percent is an acceptable range and is consistent with values historically reported.

Performance periods for individual pavement designs and rehabilitation strategies have a significant impact on analysis results. Longer performance periods for individual pavement designs require fewer rehabilitation projects and associated agency and work zones user costs.

While most analyses include traditional agency costs, some do not fully account for the agency's engineering and construction management overhead, especially on future rehabilitations. This can be a serious oversight on short-lived rehabilitations as agency design processes lengthen in an era of downsizing.

ANALYSIS PERIOD

The analysis period is the length of time (usually in years) that is selected for consideration of the life cycle costs. It is customary to designate the final year of new construction (on multi-year projects) as "year 0," and subsequent years as "year 1," "year 2," etc. This is a convenient way to structure the cost streams throughout the period considered. The particular period selected is usually based on the policy of the agency concerned. However, the NPV method allows the discounted costs of alternative strategies to be compared with each other for any period. The method can be applied to short-term as well as long-term facilities.

The analysis period is not necessarily the service life of the pavement. This distinction has vexed some engineers and caused confusion in the proper application of life cycle costing analyses. Most pavements are constructed for long-term benefits to society and experience has shown that many are still in service 30 or more years after initial construction. Agencies frequently opt for 20, 30 or 40 years in their life cycle costing analyses. In fact, any period is acceptable provided that the application of the method recognizes the following guidelines:

4. Selection of the analysis period should not be biased in favor of any particular design or maintenance strategy.
5. The analysis period should not extend beyond the period of reliable forecasting.

Routine, reactive type annual maintenance costs have only a marginal effect on NPV. They are hard to obtain, generally very small in comparison to initial construction and rehabilitation costs, and differentials between competing pavement strategies are usually very small, particularly when discounted over 30- to 40-year analysis periods.

Salvage value should be based on the remaining life of an alternative at the end of the analysis period as a prorated share of the last rehabilitation cost.

USER COSTS

User costs are the delay, vehicle operating, and crash costs incurred by the users of a facility and should be included in the LCCA. Vehicle delay and crash costs are unlikely to vary among alternative pavement designs between periods of construction, maintenance, and rehabilitation operations. Although vehicle operating costs are likely to vary during periods of normal operations for different pavement design strategies, there is little research on quantifying such Vehicle Operating Cost (VOC) differentials under the pavement condition levels prevailing in the U.S.A.

User costs are heavily influenced by current and future roadway operating characteristics. They are directly related to the current and future traffic demand, facility capacity, and the timing, duration, and frequency of work zone-induced capacity restrictions, as well as any circuitous mileage caused by detours. Directional hourly traffic demand forecasts for the analysis year in question are essential for determining work zone user costs.

As long as work zone capacity exceeds vehicle demand on the facility, user costs are normally manageable and represent more of an inconvenience than a serious cost to the traveling public. When vehicle demand on the facility exceeds work zone capacity, the facility operates under forced-flow conditions and user costs can be immense. Queuing costs can account for more than 95 percent of work zone user costs with the lion's share of the cost being the delay time of crawling through long, slow-moving queues.

Different vehicle classes have different operating characteristics and associated operating costs, and as a result, user costs should be analyzed for at least three broad vehicle classes: Passenger Vehicles, Single-Unit Trucks, and Combination Trucks.

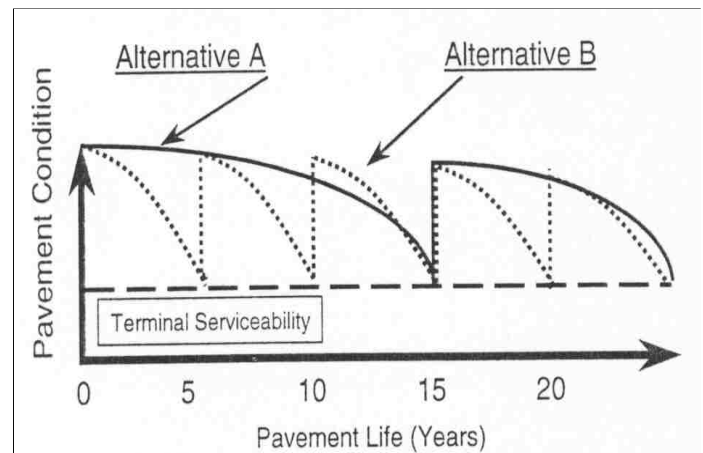

User delay cost rates are probably the most contentious of the user cost inputs. While there are several different sources for the dollar value of time delay, it is important to note that commercial vehicles support higher values of travel time delay rates and that passenger vehicles, particularly pickup trucks, represent both commercial and noncommercial use.

Work zone crash cost differentials between alternatives are very difficult to determine because of the lack of hard statistically significant data on work zone crash rates and the difficulty in determining vehicle work zone exposure. However, default dollar value ranges associated with fatal and nonfatal injury highway crashes are included.

CDOT's method incorporates user cost. At present they are doing a review of their cost

and are updating to provide a more timely analysis.

LEVEL OF DETAIL The relative influence of individual life-cycle cost factors on analysis results may varied from major to minor to insignificant. The analyst should ensure that the level of detail incorporated in an LCCA is consistent with the level of investment decision under consideration. There comes a point of diminishing returns as more and more cost factors are incorporated in an LCCA. For example, slight differences in future costs have a marginal effect on discounted present value. Including such factors as this unnecessarily complicates the analysis without providing tangible improvement in analysis results. Including the factors in every analysis is frequently not productive. The difficulty in capturing some costs makes omitting them the more prudent choice, particularly when the effect on the LCCA results is marginal at best.

In conducting an LCCA, analysts should evaluate the factors for inclusion and explain the rationale for eliminating factors. Such explanations make analysis results more supportable when they are scrutinized by critics who are not pleased with the analysis outcome.

A good reference relating to life cycle cost analysis is the Federal Highway Administration publication no. FHWA-SA-98-079. This publication can be obtained from FHWA.

LCCA PROGRAM

The Colorado Asphalt Pavement Association has developed for distribution a Life Cycle Cost (LCCA) computer program, with estimated cost, which should provide an agency with a way to quickly analysis life cycle cost for various pavement designs and maintenance strategies. The LCCA software and a User Guide can be obtained from CAPA. Also available is another LCCA program developed by the Asphalt Pavement Alliance. A copy of the APA software can be obtained from them (see Appendix E).

When using any software program, care should be taken in developing input costs data, especially those cost associated with user cost and maintenance cost.

CAPA has developed a separate document “Life Cycle Cost Analysis: Strategy Selection and Alternate Analysis”. This document is available as part of the Asphalt Technical Resources CD, 2006.

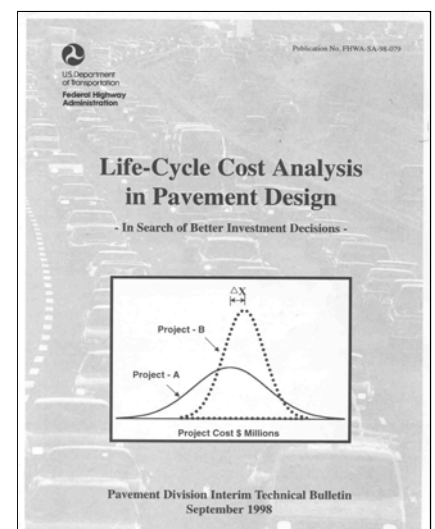

CHAPTER ELEVEN

PAVEMENT MANAGEMENT

CHAPTER ELEVEN

PAVEMENT MANAGEMENT

PAVEMENT MANAGEMENT CONCEPTS

Historically, small agencies have developed an informal process for managing pavement systems. Pavements are examined periodically and the worst ones are repaired, rehabilitated, or reconstructed. At times, the public may bring pressure to bear to repair a particular street or road. Through the years, this informal process has worked because the knowledge, experience, and common sense of those in decision-making positions led to logical street and highway programs.

Over the years, however, as traffic volumes and vehicle loadings increasingly burden pavements, local governments' maintenance budgets have not kept pace with the rising costs of labor, materials, and equipment. Because local agencies today are faced with increasing economic demands, a more systematic process is needed to justify and account for pavement maintenance expenditures and make optimal use of limited funds.

More and more agencies are adopting pavement management systems that will answer the following questions:

- How does one determine what pavement should be repaired?
- When is the best time to schedule repair, resealing, or resurfacing?
- What is the savings or cost of deferring repairs?
- What is the most cost-effective action to take in repair or restoration within a given time frame?



Pavement management can be defined as “***an orderly process for providing, operating, maintaining, repairing, and restoring a network of pavements***”. It is the process of overseeing the maintenance and repair of a network of roadways. In effect, every highway superintendent does pavement management. Pavement management offers the potential for improving road conditions and reducing pavement maintenance costs, simultaneously!

The decision to repair or rehabilitate is complicated because of the variety of types of pavement distress - some serious and others relatively minor. If pavements with some serious levels of distress are not rehabilitated in an expedient manner, their ultimate repair may be significantly more costly. An overlay made at the proper time in the life of a pavement, for example, may

extend its life for many years. If not overlaid, the same pavement may require complete reconstruction. Figure 11-1 shows the relationship over time the cumulative traffic has on the life of an HMA pavement. The Pavement Serviceability Index decreases with time and with an

Figure 11-1 Typical Relationship between Pavement Quality and Time

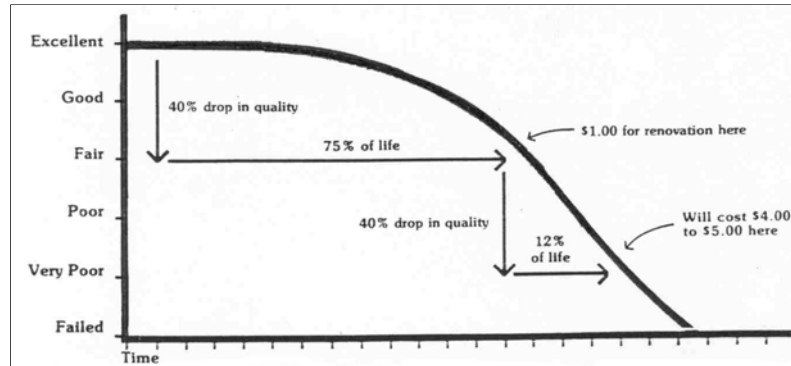

increase in the number of ESALs (traffic). The proper maintenance applied at the proper time will extend the life of the pavement.

A pavement management system is a systematic approach to inventorying your pavement system components, evaluating their condition, developing strategies for maintenance and then prioritizing according to needs and funding. Figure 11-2 is a flow chart of steps involved in developing a pavement management system and setting up a maintenance improvement program.

Implementing a pavement management program involves the development of a record-keeping strategy with the appropriate forms. The procedures can be relatively simple or very complex depending on the needs of the agency. Complex and costly computer programs are used in large jurisdictions. In the case of a smaller street or road network, there are a number of computer programs available from consultants, or through public agencies. The American Public Works Association in conjunction with the Corps of Engineers has developed **PAVER®** and **Micro PAVER®**, pavement management systems for local entities. These two programs are available from APWA for a relatively low fee.

When fully developed and implemented a pavement management system will have the capability of reporting the current condition of the roadway network and be able to determine the effect of different funding scenarios on the projected condition of the network. In addition, a pavement management system will assist in making project selection decisions to maximize the effectiveness of a maintenance and rehabilitation program. A system will also help in analyzing the effectiveness of various treatment, which will improve pavement life cycle cost analysis procedures. In simple terms, a pavement management system will help optimize the use of road improvement funds.

Figure 11-2 Flow Chart for Developing a PMS

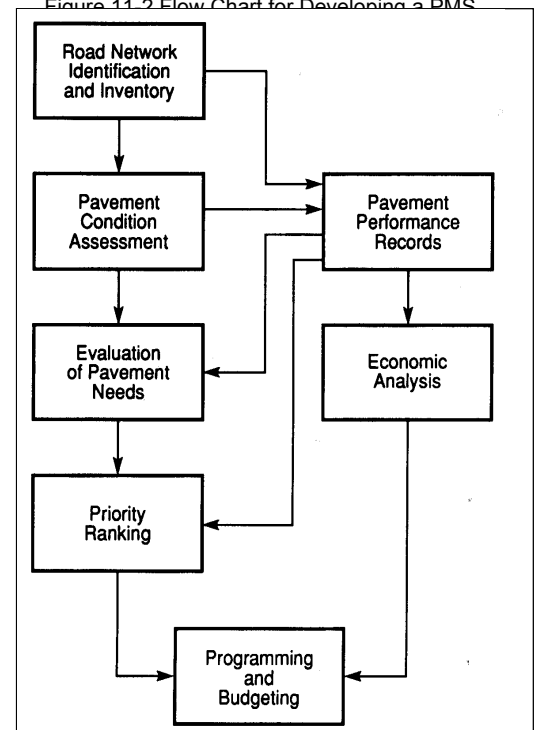

The objective of this chapter is to offer a basic approach for developing a pavement maintenance/management program. This method may be used by agency personnel who cannot devote a lot of time to planning, but who recognize that maintenance needs must now be documented in order to procure adequate funds. What is being presented here is a simple five step approach. The five steps to a pavement management system for the maintenance of pavements are as follows:

1. **Pavement inventory** ~ Delineate the various section of pavement in order to identify the various areas of pavement with different makeup, capabilities and use (i.e. local, collector or arterial roadways, different pavement thickness, age in the system, etc) which may need different strategies for maintenance.
2. **Pavement condition survey** ~ Survey the pavement condition and document the required maintenance for each pavement section.
3. **Project ranking** ~ Rank projects in order to assure that the most severe and the most cost-effective projects are considered first.
4. **Programming** ~ Programming and scheduling taking into account the level of funding available to do the work.
5. **Implementation and Record Keeping** ~ Implementation of the program and represent the feedback between maintenance needs and fiscal resources. This step also relates the program to the realized outcome (work completed) and the increase in the pavement condition.

Each step of the five steps is explained in the following sections.

Pavement Inventory ~ Step 1

Using subdivision or city street maps to identify and record paved areas to be included in the pavement condition survey. It may be appropriate to divide some longer roadways into shorter segments. For large parking lots or aprons it may also be beneficial to separate the parking lots and aprons into smaller areas such as "north parking lot", "south parking apron" etc.

Pavement Condition Survey ~ Step 2

The form shown in Figure 11-3 can be used to conduct a pavement condition survey for the various sections delineated in step 1. The inspector should take advantage of the space provided for comments to record any observation that might affect the work to be recommended. For instance, if the pavement condition is fair and appears to have deteriorated faster than would be expected due to a drainage problem, then this should be noted. In this case a plan for treating the drainage problem would be an essential part of maintaining the pavement area.

PAVEMENT CONDITION SURVEY

Inspector:

Date:

Pavement Section:

PAVEMENT AREA CONDITION AND CHARACTERISTICS: Check the appropriate box

1. Pavement Condition Rating:

- Excellent Little distress. New or nearly new pavement.
- Good Significant distress. Treatable with sealing and patching
- Fair Moderate distress. Deteriorating rapidly.
- Poor Extensive distress. Thins overlays may be ineffective.
- Very Poor Near Failure
- Failure Dangerous. Requires constant repair.

2. Drainage Condition Rating:

- Good Ditches, culverts, inlets clean. Road shoulders slope down away from pavement edge in all places.
- Fair Interruptions to drainage such as vegetation or silt build-up causing ponding and runoff delays.
- Poor Ditches are not clean, culverts, inlets clogged. Roadway shoulders are often higher than roadway.

General comments regarding observations (reference comments to I or II above)

Recommended Actions (reference to I or II above)

Year when this work should take place:

Estimated Cost:

Who will accomplish work:

Action Completed (reference I, II, or III above) ~ describe action taken, by whom, expenditures, areas treated and dates:

The year specified for proposed maintenance or improvements is important. The inspector should estimate the best time to perform the work and, if possible, include a comment about the alternatives. For instance, the recommendations might be to resurface in year two, with the comment that if the overlay is not in place within three years, reconstruction of the pavement and base will be required.

Project Ranking ~ Step 3

When the pavement survey is complete and maintenance needs have been determined, the next step is to rank the recommended maintenance actions. Pavements in the poorest conditions may have the highest priority; these sections cause unnecessary wear and tear to automobiles and trucks, are expensive to maintain, and may be hazardous. Yet, the best pavement areas, those which are well built and in good condition, represent an investment, which should be protected against normal deterioration. The following formula can be used to help determine which pavement area has priority:

$$P = PC \times (TV + TT) \times D$$

Where: P = priority
 PC = pavement condition
 TV = traffic volume
 TT = truck traffic
 D = drainage condition

Notice this formulation requires that descriptive information from the survey form be translated into numeric values. The numeric value for the descriptive information for the **Pavement Condition, Traffic Volumes, Truck Traffic and Drainage Condition** Is Shown in Table 11-1.

Table 11-1
 Numeric Values for Descriptive Condition Rating

Condition Descriptive Rating	Numeric Value
Pavement Condition	
Excellent	1
Good	2
Fair	3
Poor	4
Very Poor	5
Failure	6
Traffic Volume	
Low	1
Medium	2
High	3
Truck Traffic	
Low	1
Medium	2
High	3

Table 11-2 shows an example of the priority rating using the above formula.

Year	Pavement Areas	Pavement Condition	Traffic Volume	Truck Traffic	Drainage Condition	Priority Score
1	Main	4	3	2	1	20
1	Grand	4	2	2	1	16
2	Church	3	2	2	1	12

Programming ~ Step 4

Having listed maintenance needs and their relative priorities within each type of maintenance project, the time has come to decide where to spend the limited funds available and whether additional funds should be appropriated. First the cost of each project must be estimated. The entity should make a short list of unit costs for treatments used recently. It may be convenient to specify average unit costs for specific procedures, such as crack sealing, 1½" overlays, etc.

The Asphalt Institute has also developed a pavement rating system for low-volume asphalt pavement areas. Information about its system is contained in *Information Series No. 169 (IS-169)*. The subject also is covered in some detail in *The Asphalt Handbook guide series No. 4 (MS-4)*. A brief description of the Asphalt Institute's procedures follows in the next section.

Implementation and Record Keeping ~ Step 5

Keeping good records is an essential part of this process. Accurate records will show how the yearly strategies are working and if in the future any changes to these strategies are needed if the desired results are not being met.

RATING A ROAD

The Asphalt Institute's publications, *Information Series No. 169 (IS-169)* and *The Asphalt Handbook guide series No. 4 (MS-4)* provide a system for any individual or agency to inspect a road, rate it, and interpret the results. What is needed is an individual or individuals with maintenance knowledge - such as a superintendent or foreman - to walk the road and assign a numerical value to each type of pavement defect. The type of distress, the extent of the distress, and its relative seriousness should be recorded.

In the procedure used in this guideline, lower values are assigned to less serious problems and higher values to the more serious ones. A rating of zero indicates that the pavement is relatively free of defects. A rating of five or ten would indicate a particular type of serious distress. After each defect has been rated, the individual ratings are added. The sum is then subtracted from 100 and the result is a condition rating for that particular section of roadway. Figure 11-4 shows a form for the rating of asphalt pavements developed by the Asphalt Institute. The form shown has been modified to include specific information relating to weather at the time of inspection.

It is important that pavements are evaluated in a consistent manner. Personnel conducting a condition rating survey should have knowledge of the various types of defects, their cause, and the remedial action required. A procedure for troubleshooting and identifying pavement failures is included in Chapter Fourteen of this Design Guide. Additional detailed information on this subject is available in The Asphalt Institute's publications *(MS-16)*, *(MS-17)*, *(MS-4)*, and from the **"Distress Identification Manual for the Long-Term Pavement Performance Project"**, a Strategic Highway Research Program (SHRP) publication, SHRP-P-338. This manual can be used as a guide to help the raters in their evaluation. Color photographs and drawings illustrate the distresses found in pavement. Drawings of the distress types provide a reference to assess their severity. Methods for measuring the size of distresses and for assigning severity levels are given. The manual also describes how to conduct the distress survey, from obtaining traffic control to measuring the cracks in the pavement. Sample forms for recording and reporting the data are also included. The manual also tells how to calibrate and operate profile and fault measurement devices. This manual (SHRP-P-338) can be obtained through the Federal Highway Administration.

Asphalt Pavement Rating Form		
Rater: _____	Date: _____	
Weather Conditions: _____	Temp.: _____	
Pavement Section: _____	Type: _____	
Area: Length _____	Width _____	
Pavement Section Rating		
<small>(Note: A rating of "0" indicates defect does not occur)</small>		
Defects		Rating
Transverse Cracks	0 - 5	_____
Longitudinal Cracks	0 - 5	_____
Alligator Cracks	0 - 10	_____
Shrinkage Cracks	0 - 5	_____
Rutting	0 - 10	_____
Corrugations	0 - 5	_____
Raveling	0 - 5	_____
Shoving or Pushing	0 - 10	_____
Pot Holes	0 - 10	_____
Flushing (Excess Asphalt)	0 - 10	_____
Polished Aggregate	0 - 5	_____
Deficient Drainage	0 - 10	_____
Overall Riding Quality (0 is excellent, 10 very poor)	0 - 10	_____
Sum of Defects Ratings		_____
Condition Rating = 100 - Sum of Defects Rating		
= 100 - _____		
Condition Rating = _____		
Comments: _____		

INTERPRETATION OF A CONDITION RATING

The absolute or total numerical value assigned by the condition rating provides an indicator of the type and degree of repair work necessary. As a general rule, if the condition rating is between eighty and 100, normal maintenance operations (crack-filling, pothole repair, or seal coat) are required. If the condition rating falls below eighty, it is likely that an overlay will be necessary. If the condition rating is below thirty, major reconstruction may be necessary.

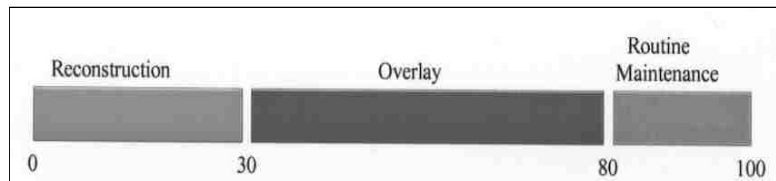

Figure 11-5 shows the suggested zone for maintenance and rehabilitation strategies.

Another valuable use for the condition rating is to provide a rational method for ranking roads and streets according to their condition. A priority ranking should be the basis for programming and budgeting maintenance, rehabilitation, and reconstruction.

PAVEMENT MAINTENANCE

Pavement maintenance is the work performed to keep a pavement, which is exposed to normal conditions of traffic and nature, as near to its original condition as possible. Because destructive environmental and traffic forces are constantly at work, pavements require maintenance. Cracks, holes, depressions, and other types of distress are the visible evidence of pavement wear. Pavement cuts for utility access and repairs are major contributors to the need for pavement maintenance.

Taking care of pavement deterioration at the proper time and in the proper manner can significantly increase the useful life of a pavement. Early detection and repair of minor defects are among the most important activities of road maintenance crews. In their first stages, cracks and other surface breaks are almost unnoticeable, but they may develop into serious defects if not soon repaired. Open joints and cracks allow water to enter the subgrade and lead to pumping and faulting with resultant structural failure. It has been estimated that on rural pavements in Colorado, seventy percent of the subgrade moisture originates at the edge of the pavements. This problem can be greatly helped by an aggressive ditch maintenance program.



Pavement maintenance also involves the identification of pavement distress types and the determination of appropriate maintenance activities. The following sections provide information on full-depth patching, thin overlays, and overlays greater than 1.5 inches.

Routine Maintenance ~ For roads in reasonably good condition, routine maintenance is generally the most cost-effective use of funds. If at all possible, routine maintenance needs should be funded each year. Routine maintenance usually includes patching, crack sealing and other relatively low-cost actions. Distresses which present the most negative impact on the performance of a section are usually corrected first.

Preventive Maintenance ~ This strategy is a more expensive activity designed to arrest deterioration before it becomes a serious problem. Surface seals are excellent examples of preventive maintenance. A common source of poor performance of seals is adequate repair of existing distress before sealing so extensive repair work may also be included in preventive maintenance. Repair and seal needs will probably have to be programmed over several years in order of priority because of their costs. Routine maintenance should be performed on those sections that are not programmed for current budget year.

Deferred Action ~ The road sections which fall into this category receive minimum funds for the current budget year. These sections are beyond the point where preventive maintenance will be effective but have not yet deteriorated to the point of needing rehabilitation. Selecting this strategy is deferring action, so an agency must be prepared to fund rehabilitation or reconstruction when it becomes necessary.



Rehabilitation (Resurfacing) ~ Rehabilitation usually includes overlays or extensive recycling. Funding for completion of these major projects may depend upon federal or other outside sources. This type of rehabilitation is referred to as "Resurfacing" by CDOT. The established priorities should be followed if possible, although managers should realize that priorities may change for a variety of reasons. For example, estimates for a particular job may exceed available funds, insurmountable administrative restrictions on funds may exist, or very valid political reasons to change priorities may occur. Sections that fall into this strategy category that

are not programmed for the current budget year should fall into the deferred action strategy.

Reconstruction ~ The comments on rehabilitation projects also apply to reconstruction projects. The main difference is in the costs that might be expected. Reconstruction would involve complete removal and replacement of a failed pavement such as widening, realignment, traffic control devices, safety hardware and major drainage work. Lead times of one to ten years may be required due to the monetary investments and time necessary to develop plans, acquire right-of-way and so forth.

Table 11-4 provides asphalt pavement maintenance alternatives along with comments about performance.

Table 11-4
Maintenance Alternatives

Treatment	Comments of Performance
Fog Seal Diluted emulsion	Renews and enriches oxidized surface; seals minor cracks; prevents raveling; provides shoulder delineation. The emulsions use for fog seals can be Gilsonite and Polymer modified. Reclaiming and rejuvenating emulsions can also be used. Coal Tar sealers should <i>only</i> be used on refueling areas.
Sand Seal About 3/16" thick	Generally this is the lowest initial cost type of sealing coating application, it seals only and does not add structural strength, does not level, smooth or correct crown significantly unless pre-leveling is done first. The average service life is 3-6 years. The main advantage is that it can be done with local labor and sometimes aggregate. Castings are not generally adjusted. Application is not appropriate for grooved runways or heavy aircraft traffic areas.
Slurry Seal Coat Single 1/8" thick = 25 lb./sq. yd. (A specialty contractor must apply it.)	Moderate to higher initial cost application due to full contract required. Main advantage quicker, neater application. Castings generally do not need adjusting; should be applied in good, low humidity weather. Average life, single application 3-5 years, double application 5-8 years. Provides smooth, tight surface similar to hot mix. Good for low and moderate volume pavements. Not recommended for grooved runways.
Aggregate or Chip Seals 3/8" thick 3/8" - 1/2" Chips 33 to 45 lb./sq. yd.	Low to moderate initial cost depending on local labor and aggregate sources. Castings generally are not adjusted. A good chip seal provides excellent skid resistance and provides attractive color by choice of stone. The average life is 5 to 8 years.
Plant Mix Seal Coats - Thin Hot Mix Overlay high quality, thoroughly controlled hot mixture of asphalt cement and well-graded, high quality aggregate, thoroughly compacted into a uniform dense mass.	The higher cost thin hot mix overlays (less than 1" thick) are also considered as sealing treatments primarily and not structural improvements. They also smooth the surface quite a bit. Very rough surfaces need to be pre-leveled or mix will apply poorly and mat will have to be thickened. Thinner treatments used on lower volume pavement areas in better shape, thicker treatments on higher volume pavement areas and rougher surfaces. Multiple treatments if applied in timely stages can add strength. Care must be taken; these relatively stiff treatments are not put on pavement areas that need of significant structural upgrading as large deflections will cause the surface to crack. The average life is 6-12 years.
Structural Overlay - Thick Hot Mix 1-1/2" - 2" thick = Structural overlay and also seals. Probably the most common Rehabilitation treatment. (Recommended minimum two inch overlay).	1-1/2" to 2" overlay not only seal but adds significant structural capacity (depending on existing thickness). It seals, smoothes the ride and corrects crown and drainage features substantially. Extra rough pavement areas may require pre-leveling prior to overlay. This treatment is the highest form of maintenance and upgrading treatment for low volume pavement areas and is the most expensive of treatments listed here. Average life is 15-20 years on high volume pavement areas, longer on lower volume pavement areas.

CRACK SEALING

WATER IS THE MOST DESTRUCTIVE element to pavement. Asphalt pavements expand and contract with seasonal temperature changes. Consequently, cracks and joints are expanding and contracting when the pavements move. Sealing the cracks with a flexible rubberized asphalt that bonds to the crack walls and moves with the pavement will prevent water intrusion. Simply stated, sealing cracks and joints in pavements extends the service life of the surface treatment and the pavement. In fact, pavement areas that have been crack sealed have better rideability five years



later than those receiving only surface treatments, such as chip seals, micro-paving, thin overlays and slurry seals. Crack sealing treatments enhance the surface treatment and further extend the pavement life. Crack sealing provides the most cost-effective use of dollars over time compared to other pavement maintenance techniques.

The ability to produce a material that will not be soft and track in the summer and still be flexible in freezing temperatures requires research. To ensure a minimum standard for sealant performance, the American Society of Testing and Materials (ASTM), the American Associations of State Highway and Transportation Officials (AASHTO) and federal agencies have developed test specifications for polymer-modified and asphalt rubber sealants. Today's sealants are highly engineered products formulated to perform in some of the most difficult climatic conditions.

Surface Preparation

Using the right equipment is an important part of any crack sealing program. There are two major areas of consideration: 1) crack preparation and sealant application, and 2) cracks must be free of dirt, dust and debris. The sealant must have a clean, dry bonding surface. Surface preparation can be accomplished with compressed air and a simple blow pipe. This technique works well when the dirt is dry and not packed hard. If the cracks are filled with wet dirt, the dirt needs to be removed and the crack must be completely dried. In this case an a hot air lance generating temperatures in excess of 2,000° F is the best tool. In simple terms, a heat lance uses hot, compressed air to blow cracks clean while drying them out. Also the use of a router to enlarge small cracks so a consistent, uniform reservoir for sealant is obtained. Results from A SHRP study showed there is almost a forty percent greater chance of sealant success if cracks are routed prior to sealing. (Note: Older-aged asphalt pavements and thin asphalt pavements may not be suitable for routing.)

Although roofing tar pots are still used for applying mineral-filled materials, they will burn or destroy crack and joint sealants that utilize polymers or rubber. Melters eliminate this problem by using a high-temperature heat-transfer medium, such as oil. These types of melters are known as "oil jacketed" melters or "double boilers". Hot pour sealants are effectively applied through a delivery hose and wand. These materials are commonly applied at 375° F. To prevent sealant cooling, set up and clogging, the hose is placed under constant pressure and the sealant constantly circulates back into the main tank. Crew members therefore must be trained not only in proper safety procedures but also in proper operation of the melter.



Sealant Application

The sealant can be placed flush with the pavement, slightly below the surface of the pavement or slightly above the surface. In an overband configuration, the sealant is placed onto and over an un-routed crack. The sealant can be shaped into a band over the crack using a rubber blade squeegee or a sealing shoe that flattens the sealant over the crack. When a pavement is to be overlaid shortly after crack sealing, an overband configuration is not

recommended because the extra crack filler will cause problems with the overlay. When an overlay is to follow crack filling, the crack sealant should be struck off flush with the pavement surface. A leveling or scratch coat of HMA should be planned for, or the overlay should be postponed for 6-12 month for the crack filler material to cure and stabilize.

Pavement selection is often the forgotten element in determining the success or failure of a sealant program. If the pavement section has alligator cracking, high-density multiple cracking, poor sub-base drainage or structural damage, crack sealing will not solve the problem. In these cases the damage is too severe. If you try to save a pavement with too much cracking, you will be disappointed with your efforts. The best candidates for crack sealing are newer pavements that are beginning to form cracks. You certainly can extend the life of these pavement areas. More sealant is not always better. The new sealants are not designed to be "**road glue**". They are very sticky and have tremendous bonding power, but they are not made to "**hold the road together**". Crack sealing has one objective: to prevent water flowing into and under the pavement layer to prevent further damage to pavement areas. Sealing buys time and saves money by delaying the expense of major reconstructive pavement work.

FULL DEPTH HOT MIX ASPHALT PATCHING

The full-depth HMA patch is an important maintenance technique for protecting and preserving the sizable investment in pavement areas. It is used to repair all types of localized pavement distress that extend below the pavement area surface. Examples include potholes, alligator cracking, upheaval, and shoving.

The procedure is intended to remove the failed area and replace it with fresh HMA mix. Although the operation is not difficult, some of the necessary fine points are frequently not given sufficient attention. Yet these details often determine whether the completed patch will be a temporary expedient or an integral part of a functional pavement system.

The following ten steps outline the correct procedure for constructing a full-depth patch:

1. With a pavement saw or pneumatic hammer, cut the outline of the patch, extending at least one foot outside of the distressed area. The outline should be square or rectangular with two of the sides at right angles to the direction of traffic.
2. Excavate as much pavement as necessary to reach firm support. If a patch is to be an integral part of the pavement, its foundation should be as strong as or stronger than that of the original pavement area. This may mean that some of the subgrade will also have to be removed. The faces of the excavation should be straight and vertical.
3. Trim and compact the subgrade.
4. Apply a tack coat to the vertical faces of the excavation. Emulsified asphalts or liquid asphalt are suitable.



5. Backfill with the asphalt mixture. Shovel the mixture directly from the truck into the prepared excavation. Place the mixture against the edges of the hole first (rather than in the center and then raking to the edges). The maximum lift thickness largely depends upon the type of asphalt mixture and the available compaction equipment. Hot mix asphalt can and should be placed in deep lifts, because the greater heat retention of the thicker layers facilitates compaction. From a compaction standpoint, patches using hot mix asphalt can be backfilled in one lift. However, when placing



a patch that is deeper than 5 inches, it is often useful to leave the first lift 1 to 2 inches below the finished grade, making it easier to judge the total quantity of mixture required for the patch.

6. Spread carefully to avoid segregation of the mixture. Avoid pulling the material from the center of the patch to the edges. If more material is needed at the edge, it should be deposited there and the excess raked away. The amount of mixture used should be sufficient to ensure that after compaction, the patch surface will not be below that of the adjacent pavement. On the other hand, if too much material is used, a hump will result.

7. Compact each lift of the patch thoroughly. Use equipment that is suited for the size of the job. A vibratory plate compactor is excellent for small jobs, while a vibratory roller is likely to be more effective for larger areas.

8. When compacting the final lift (which may be the only lift), overlap the first pass with the second pass about six inches with the vibratory roller or plate compactor. Then move to the opposite side and repeat the process. Once this is accomplished, proceed at right angles to the compacted edges with each pass and return, overlapping a few inches on the uncompacted mix. If there is a grade or slope, compaction should proceed from the low side to the high side to minimize possible shoving of the mix.

9. When adequate compaction equipment is used, the surface of the finished patch should be at the same elevation as the surrounding pavement. However, if hand tamping or other light compaction methods are used, the surface of the completed patch should be left slightly higher than the adjacent pavement as the patch is likely to be further compressed with traffic.

10. Check the vertical alignment and smoothness of the patch with a straight edge or string line.

HOT MIX ASPHALT (HMA) OVERLAYS

As discussed earlier under pavement management concepts, the condition rating provides a rational method for evaluating the need for an overlay. If the condition rating falls below 80, it probably calls for an overlay. Deferring the overlay allows further deterioration of the pavement. At some point in time, the life of the pavement is severely affected, which will

increase costs significantly.

The predictive capabilities of a pavement management system allow an agency to analyze alternative programs and select a maintenance strategy that is cost effective. Deferred maintenance is more costly in the long run as illustrated by the quality of deterioration over time example.

Hot Mix Asphalt (HMA) is an excellent resurfacing material that is equally effective for overlaying asphalt/aggregate surfaces, HMA pavements, or Portland cement pavements. HMA overlays add strength to an old pavement structure, extend service life, and provide a smooth, skid-resistant pavement. They improve riding quality, cross section, and they increase a pavement's resistance to water intrusion and de-icing chemicals. The result is a better riding surface and a stronger pavement than the original.

ADVANTAGES

An HMA overlay offers the following advantages:

1. Convenience. The pavement may remain in use while it is being upgraded.
2. Economy. An old pavement frequently may be improved and returned to service more quickly and for less cost than a new road can be constructed.
3. Durability. Well-designed, well-constructed improvements provide a pavement that is stronger than new, which reduces maintenance requirements.

DESIGN CONSIDERATIONS

Each resurfacing project should be designed on an individual basis. Before constructing an HMA overlay, careful and correct preparation of the existing pavement is essential for maximum pavement performance.

Local Repairs ~ Weak areas should be repaired. Structural patches should be designed and constructed with full-depth HMA to ensure strength equal to or exceeding that of the surrounding pavement. Carefully placed and adequately compacted patches will produce uniform support for the overlay and ensure good performance

Structural Deficiencies ~ Pavement deficiencies that do not affect structural adequacy are usually corrected by thin resurfacing using thicknesses selected from experience. Weakened pavement structures call for overlays of designed thicknesses that will sufficiently strengthen the pavement structure to accommodate the traffic expected to use it.

Drainage ~ Older pavements may show signs of fatigue because of intrusion of groundwater from below or from surface water entering along the edge between the pavement and the shoulder. This water should be removed by under drains or by other means several weeks before constructing the HMA overlay.

Leveling ~ When the surface is distorted, the construction of a leveling courses or wedges is required to restore proper line and cross section.

Overlay Thickness ~ HMA overlays may be used to correct both surface and structural deficiencies. Present pavement condition and estimates of future traffic influence appropriate thickness of these overlays. If a pavement has failed by plastic deformation, evidenced by rutting and shoving, the depth of the failed area should be identified and removed by milling prior to placement of an overlay. A two-inch average depth of HMA surface should be the minimum thickness. As a standard rule, the lift thickness should be at least twice the maximum aggregate size in the mixture. This standard rule has been increased to three times the nominal maximum aggregate size due to the PG graded asphalt binders' superpave aggregate specifications. Mixes using PG binders require hotter temperatures for mixing and a larger compaction effort to obtain the proper densities. Overlay thickness can be calculated using the procedures discussed in Chapter Three.

REFERENCE PUBLICATIONS

Publications referenced in this chapter can be obtain from the respective organizations. A list of their web sites is included in Appendix C.

CHAPTER TWELVE

PAVEMENT REHABILITATION AND RUBBLIZATION

CHAPTER TWELVE

PAVEMENT REHABILITATION AND RUBBLIZATION

ASPHALT PAVEMENT REHABILITATION

The performance of a pavement is affected by the type, time of application and quality of the repair it receives. Preventive timely maintenance slows the rate of pavement deterioration due to traffic and environmentally applied loads. Delays in maintenance and deferred maintenance increase the quantity of defects and their severity so that, when corrected, the cost of repair is greater. Continued deferral of maintenance and rehabilitation actions shortens the time between overlays and reconstruction, and thus increases the life cycle costs of a pavement considerably.

Generally maintenance activities are divided into two categories, preventive and corrective maintenance. Preventive maintenance is that group of activities performed to protect the pavement and decrease the rate of deterioration of the pavement quality. Corrective maintenance is that group of activities or strategies performed to correct a specific pavement failure or area of distress. This chapter deals with the more common strategies that correct pavement failure or area of distress that rehabilitate the existing roadway surface.



Pavement evaluation is the first step in the process of developing pavement rehabilitation alternatives for a project. Since rehabilitation goes beyond preserving a pavement structure, the engineer should learn as much as possible about the existing pavement system to understand the extent and cause of existing problems prior to developing a rehabilitation plan.

Monitoring of pavement condition is done on a "network level" to define the status of an entire pavement network as part of a pavement management system. Typically, an agency will periodically measure ride quality and surface friction, and perform cursory distress surveys on sample units of pavement sections in their network. This type of network evaluation is useful for establishing data that can be analyzed to discern trends in pavement performance. Condition versus time relationships can be identified for different pavement types, uses, etc. These relationships can be used to identify when preventive maintenance practices should be applied or to estimate when rehabilitation or reconstruction will be necessary. This type of network monitoring as part of a pavement management system can be used to help prioritize and select projects.

Collecting data at the network level alone **is not** sufficient for developing proper rehabilitation alternatives for a specific project. Rather, more detailed "project level" pavement evaluation data is needed to provide the information required for properly selecting a rehabilitation alternative and designing the project. Some pavement evaluation considerations for rehabilitation design include ride quality and surface friction measurements, distress surveys, deflection measurements and testing of in-situ materials. In this chapter, tools and techniques commonly used for pavement evaluation at both the network and project levels are briefly described. These tools and techniques are categorized into three major activities:

- Assess the functional characteristics (ride quality and surface friction)
- Conduct condition and distress surveys
- Perform structural testing (nondestructive and destructive)

In addition to collecting data that falls into these three major categories, the engineer must also define the limits and objectives of the project. This will focus the engineer to the project at hand, as well as identify any physical constraints that affect which alternatives are available. Perhaps the most common example of a physical constraint is where there is a limit to the thickness that an overlay can be placed. The amount of work required to adjust intersections, driveways, inlets and other structures to meet grade may limit the overlay thickness regardless of the existing pavement condition. Knowing these limitations ahead of time allows the designer to focus the data collection effort toward obtaining information that will be of practical use.

In some cases, physical constraints may require the designer to reconstruct rather than rehabilitate the existing pavement. In such a case, the most important types of data to collect are sub grade strength (CBR or resilient modulus, M_R) and traffic counts, from which a traffic design level can be determined.

Another important design consideration is the ability to maintain traffic during construction. If user costs are applied, the associated cost will sometimes add significantly to the project cost. When user delay costs are considered in the life cycle cost analysis, HMA will be the favorite design. This is because traffic can be returned to HMA as soon as the mix is compacted and cooled.

HOT MIX ASPHALT OVERLAYS

When pavements become structurally deficient they need additional strength to carry the loading that they are experiencing. HMA overlays can be used for the structural rehabilitation of the roadway. HMA overlays improve service to the user in many ways. They strengthen existing pavements, reduce maintenance costs and increase pavement life, provide superior ride quality, and reduce safety hazards by improving surface skid resistance. In addition, HMA overlays in conjunction with FULL-DEPTH @ widening and other geometric improvements can be used to increase roadway capacity and further improve safety.

HMA overlays provide major economic advantages to both user and agency. Agencies can provide more road miles of quality pavement because deteriorated roads can be improved and placed back into service in a shorter time and for less cost than new roads can be built. For users, both automobiles and commercial vehicles are more fuel-efficient and have less wear

and tear when operated on smooth pavements. Also, roads can remain in use while being rehabilitated.

The economics of HMA overlays can be improved by reusing reclaimed (milled) HMA from the existing pavements and incorporating it into the overlay HMA. CDOT allows up to 25% RAP in the new mix.

There are three categories of hot mix asphalt overlays:



- Heavy Structural Overlay
- Structural Overlay
- Functional (maintenance) Overlay

Heavy structural overlays range in thickness from 15 to 40 cm (5 to 16 in.). They have the longest expected life of the three overlay types; however, their longevity relies heavily on proper pavement preparation and quality of construction. The design of a heavy structural overlay would include the data collection for soils and traffic as previously mentioned. This should also

include nondestructive testing and long-range traffic forecasting such as a twenty-year analysis. Detailed specifications and plans are normally developed for this type of overlay.

Structural overlays add strength to the old pavement and last longer than maintenance overlays. They range in thickness from 10 to 15 cm (4 to 6 in.). This type of overlay can also be based on traffic forecasting and nondestructive testing, but not necessarily accompanied by detailed plans.

The purpose a **functional overlays** (maintenance) is to restore ride quality, pavement section, add structural value and restore uniform surface texture. A functional overlay is normally a dense graded asphalt mixture in the range of 5 to 10 cm (2 to 4 in.). Functional overlays should be considered stop gaps and used to prevent further pavement deterioration until a more substantial overlay is needed.

The **Ultra thin Bonded Wearing Course** is another type of HMA overlay. Its function is to provide a smooth riding surface while sealing the existing surface. The ultra thin bonded wearing course is approximately 1/2" in thickness. Therefore, it doesn't offer much in strengthening the existing structure. The ultra thin bonded wearing course is constructed by applying a warm Polymer Modified Emulsion Membrane followed immediately with an ultra thin overlay of HMA. The Polymer Modified Emulsion Membrane is spray applied immediately prior to the application of HMA overlay so as to produce a homogeneous wearing surface that can be opened to traffic immediately upon sufficient cooling. CDOT specification for this type of overlay is a good guide for the ultra thin bonded wearing course type of HMA overlay.



RECYCLING ASPHALT PAVEMENTS (RAP)

As natural resources become scarcer and more costly to obtain, their rehabilitation and re-use, and/or recycling of existing pavements becomes more important. Asphalt cement and aggregates used in roadway construction constitute a sizable public investment. They are two very important natural resources whose values as construction materials are recoverable. Portland concrete is recyclable, but only as an aggregate. In HMA both the aggregate in the mix and the binder are reusable. This ability to recycle both the aggregate and the binder has enormous implications not only for the conservation of valuable resources but also for energy savings and total economic benefits. Statistics from the National Asphalt Pavement Association (NAPA) indicate that using twenty percent RAP reduces the cost of a ton of HMA by ten to fifteen percent.

Recycled HMA pavements can be accomplished through: removal and transport to another location for crushing and reprocessing with transport to the new site for laydown and rolling; or through cold milling the surface; and/or conventional removal, with crushing, reprocessing, laydown, and rolling accomplished on the site.

Reprocessing the salvaged materials, plus the addition of virgin asphalt and new aggregates, can be accomplished through three different processes, Hot in-place Recycling, Cold mix recycling and Hot in-place repaving.

RAP Used at Plant In a Hot In-Place Recycling process, a special drum for mixing is used to comply with environmental pollution requirements and, since you can't use direct flame to heat the reclaimed pavement to allow for heat transfer to heat the RAP. The mixture produced is a fully recycled product containing fifteen to fifty percent RAP and virgin materials (binder + aggregate). The newly revised CDOT specifications allow up to 25% RAP in HMA mixes. Using twenty percent RAP and eighty percent new HMA allows for the most efficient heat transfer required for heating the total mixture and allows for the most economical production as measured by tonnage per hour produced.



When producing RAP, either by milling or crushing, the contractor should be selective and only reclaim old HMA pavement of known quality. If it is known that the old pavement contains poor quality material (aggregates or binder) it *should not* be processed as RAP. Just like any other aggregate stockpile, quality control should be performed during production of RAP so that its' oil content and aggregate gradation is known. When combining RAP into a hot mix asphalt mixture it is important to know how the use of the RAP will affect final gradation and total binder content. It is also important to know the viscosity and penetration of the old binder to determine how much it has aged and whether or not an adjustment needs to be made to the grade of the new binder. If required, an adjustment is usually made by using one grade softer oil or a rejuvenating agent.



Salvaged materials, whether previously processed or not, should be sized for the intended mix use. Final gradation of the recycled mix and virgin materials should meet the requirements for the specified mix size and type. These mixtures may be designed as S, SG, or SX grading HMA with the same quality requirements, therefore requiring no name change or designation.

HMA Recycling Advantages

- Economic savings to the project
- Significant structural improvements can be obtained with little or no change in thickness when doing in-place recycling.
- Additional right-of-way is not required to maintain traffic.
- Frost susceptibility may be reduced.
- Surface and base distortion problems may be corrected.
- Base preparation and shoulder work is reduced.

A more detailed discussion on using RAP in asphalt mixes is provided in the NAPA publication; Information Series 123 "Recycling HMA Asphalt Pavements"

COLD IN PLACE RECYCLING

A cold in-place recycling process involves processing a two inch to an eight inch depth of existing pavement followed by an HMA overlay. When cold in-place recycling, ambient temperatures should be at least 55 °F and rising, and the mat temperature should also be at least 65 °F and rising. The most common method of cold in-place recycling consists of using a "train" of several pieces of equipment. The equipment, tied together, moves down the pavement milling up the existing pavement, reprocessing it while adding new virgin materials and then relaying the combined material. Compaction equipment follows the train to compact the new material. Virgin materials added to the mix consist of aggregates to enhance overall gradation, additional binder in the form of emulsified asphalt to adjust binder content and improve viscosity and, in some cases, rejuvenating agents and additives to improve the overall performance of the mix. The recycled pavement is covered by a HMA overlay or some other type of surface treatment.

Cold in Place Recycling Advantages

- Can correct many types of pavement distress that involve both surface and base courses.
- Can improve gradation and the physical properties of the old pavement.
- Allows for 100% re-use of the old pavement thus reducing the need for new materials and overall cost.



- Hauling costs may be decreased if in-place methods are used.
- Increases structural strength without adding to pavement thickness.
- Drainage problems are avoided.

- Adding asphalt waterproofs the base and renders it less susceptible to frost action and moisture change.

It is recommended that cold in-place recycling not be performed when the existing mat temperature is below 85 °F, or when the weather is foggy or rainy, or whenever weather conditions are such that proper mixing, spreading, and compacting of the recycled material cannot be accomplished.



HOT IN-PLACE RECYCLING

A third process, termed Hot In-place Recycling or surface recycling, involves heater scarification of the top 1" of pavement followed by an HMA overlay. A "train" of equipment is used consisting of a heater scarifier, a mixer for adding new material (optional) and a laydown machine for placement. Compaction equipment follows the "train" and compacts the new material. When adding new material it is added as a hot aggregate with a minimal amount of binder. The recycled material is covered by an overlay or surface treatment.

Hot In-place Recycling Advantages

- Provides a very low-cost maintenance strategy.
- Restores flexibility of aged and brittle asphalt.
- By adding new materials, mixture properties of the old mix can be improved.
- Cracks are interrupted and filled.
- Surface distortion, removed and leveled, drainage and crowns are re-established.
- Improves skid resistance.
- Eliminates the need for surface repairs.

HOT IN-PLACE REPAVING

This process involves the heater scarification of the top $\frac{3}{4}$ " to 1" of the existing pavement, addition of a rejuvenating agent if required, the relaying of the heater scarified material and then the placement of virgin HMA mat on top of the heater scarified recycled material prior to compaction. The recycled material and the virgin mat are compacted at the same time thus, forming a hot bond between the layers. This process involves the use of a train of equipment usually consisting of a pre-heater, heater scarifier re-paver and compaction equipment. In this process the existing HMA surface is usually heated to a temperature of between 200 °F and 250 °F. When compacted with the virgin HMA provides a heat bond which is hard to distinguish between the recycled pavement layer and the virgin pavement. Joints in this process are hot joints, thus longitudinal joints are nearly non-existent. Another advantage to this process is that any rutting or uneven surface of the existing pavement less than the depth of the scarification is removed and the recycled and new mat is placed evenly on the new scarified surface. The finished mat can be opened to traffic as soon as the mat cools.

The Hot In-Place Repaving process has the same advantages as Hot In-Place Recycling, with the added advantage of the virgin material placed by the re-paver and both the recycled material and virgin mix being compacted at the same time forming a hot bond between layers. Another advantage of this process is that thinner layer of virgin material can be laid. The minimum virgin layer could be as thin a 1" since it is hot bonded to the recycled layer and compacted together. This type of rehabilitation process does not add a lot of additional height to the pavement.

REHABILITATION OVER PORTLAND CEMENT CONCRETE PAVEMENT

RUBBLIZING

The rubblizing of Portland Cement Concrete Pavement (PCCP) before Hot Mix Asphalt (HMA) overlay means the complete destruction of the concrete slab and of the concrete slab action. With this technique, the concrete-to-steel bond is broken on joint-reinforced concrete pavements and on continuously-reinforced concrete pavements. The rubblizing process effectively reduces the existing slab to an in-place crushed aggregate base.



The benefits of this method are:

- Prevents reflective cracking.
- Provides a sound base for the overlay.
- Extends service of the pavement.
- Provides a maintainable surface.
- Provides a complete flexible pavement structure with a high quality flexible stabilized granular base.

The procedural steps in the rubblizing process are:

- Install necessary drainage.
- Remove any existing overlay.
- Saw-cut the full thickness of the pavement adjacent to remaining sections.
- Pulverize the PCCP pavement.
- Cut off the exposed steel reinforcement.
- Compact the pulverized PCCP pavement.
- Apply a prime coat.
- Place the HMA leveling course and overlay.

The first rubblization plus HMA overlay in Colorado was I-76 Sterling east, placed in 1999. CDOT has published a preliminary test and evaluation report about the project. This report identified that the project was successful and future use of this type of rehabilitation strategy will be considered in the future for the rehabilitation of PCCP pavements.

CRACKING AND SEATING

PCCP pavement that has good drainage and is still relatively sound can be salvaged through cracking and seating and a Hot Mix Asphalt (HMA) overlay applied. This option for rehabilitation is designed to reduce the opportunity for reflective cracking by decreasing the slab size of the PCCP. Proper breaking and seating will virtually eliminate reflective cracking. If reflective cracks should appear, they usually will be small, tight cracks that can be maintained easily.



With this method of rehabilitation, the PCCP is cracked at 24 to 30 inch intervals with heavy drop hammer equipment to create a more uniform pattern of cracking. Next, the cracked PCCP is seated with a rubber-tired roller of at least 35 tons. This seating action by the roller pushes down any pieces of PCCP that might be over a void in the subbase. After the breaking and seating steps are completed, a three to five inch asphalt overlay is placed directly on the prepared old pavement.

This method of recycling has been used for more than thirty years in many states.

This method offers the following benefits:

- Prevents or delays reflective cracking.
- Extends pavement service life.
- Reduces maintenance costs.
- Improves riding smoothness.

The procedural steps of the breaking and seating process are:

- Crack the PCCP slabs.

- Seat cracked pieces.
- Remove and patch soft areas.
- Sweep clean.
- Apply tack coat.
- Place asphalt leveling course and then overlay.

Caution should be exercised if contemplating use of this method of rehabilitation on city streets. Some eastern cities using the rubblization method to rehabilitate city streets have found that the jarring caused by breaking and cracking of the existing PCCP pavements broke old water mains and cracked windows and walls in home adjacent to the roadway. Some of the newer non-symmetrical drum breaking equipment used to crack the pavement has less impact on adjacent property.

CHAPTER THIRTEEN

PAVEMENT MANAGEMENT FOR AIRPORTS

CHAPTER THIRTEEN

PAVEMENT MANAGEMENT FOR AIRPORTS

GENERAL CONSIDERATIONS

The Federal Aviation Administration (FAA) and Colorado Department of Aeronautics typically like to address the following items in their Pavement Maintenance Management Program:

- **Pavement Inventory** - Including location of the runways, taxiways and aprons, dimensions, types of pavement, and year of construction or most recent major rehabilitation.
- **Inspection Schedule** - Detailed inspections should be performed once a year (to update Pavement Condition Indexes, PCI) and drive-by inspections to detect changes in pavement conditions when necessary. A detailed PCI inspection is not done every year.
- **Record Keeping** - Include inspection date, location, distress types and maintenance to be scheduled, maintenance/rehabilitation performed and new construction.
- **Information Retrieval** - Make sure pavement management records are accessible.
- **Reference** - Refer to FAA Advisory Circular 150/5380-6/7 Pavement Management Systems.

The above items are typically included in an Airport Pavement Maintenance Program as well as historical pavement data and pavement maintenance cost estimates/budgets.

There is also a procedure conducted by the Colorado Aeronautical Division (part of CDOT) that establishes Pavement Condition Indexing (PCI) for most general aviation airports. This procedure is not included in this design guide.

Design of Hot Mix Asphalt (HMA) pavement sections for new construction on airports is not included in this chapter. Design of new construction should be done according to FAA Advisory Circular 150/5320-6C Airport Pavement Design and Evaluation.

PAVEMENT MANAGEMENT CONCEPTS

Historically, small airports have developed an informal process for managing pavement. Pavements are examined periodically and the worst ones are repaired, rehabilitated, or reconstructed. Through the years, this informal process has worked because the knowledge, experience, and common sense of those in decision-making positions led to logical, but highly reactionary airfield pavement management programs.

Today, with federal mandates for pavement management and increasing desire to provide facilities for higher performance corporate and commercial aircraft, local airport authorities maintenance budgets have not kept pace with the rising costs of labor, materials, and equipment. Because airport authorities today are faced with increasing economic demands, a more systematic process is needed to justify and account for pavement maintenance expenditures.

More and more airport authorities are adopting a pavement management program that will answer the following questions:

1. How does one compare pavements to prioritize maintenance?
2. When is the best time to schedule repair, resealing, resurfacing or reconstruction?
3. What is the savings or cost of deferring repairs?
4. What is the most cost-effective action to take in repair or restoration?

Just like for roadways and highways, **pavement management** can be defined as “**an orderly process for providing, operating, maintaining, repairing, and restoring a network of pavements**”. It is the process of overseeing the maintenance and repair of a network of airfield pavements. In effect, every airport manager does pavement management. Pavement management offers the potential for improved airfield pavement conditions and reduced pavement maintenance costs.

The decision to repair or rehabilitate is complicated because of the variety of types of pavement distress - some serious and others relatively minor. If pavements with some serious levels of distress are not rehabilitated in an expedient manner, their ultimate repair may be significantly more expensive. An overlay made at the proper time in the life of a pavement, for example, may extend its life for many years. If not overlaid, the same pavement may require complete reconstruction.

Carrying out a pavement management program involves the development of a record-keeping strategy with the appropriate forms. The procedures can be relatively simple or very complex depending on the size of the agency. Complex and costly computer operations are used in large jurisdictions. In the case of smaller airports, there are a number of microcomputer programs available.

Similar to Chapter Eleven, the objective of this chapter is to offer a no-frills, five step method for developing a pavement maintenance program. This method may be used by airport managers and engineers who cannot devote a lot of time to planning, but who recognize that maintenance needs must now be documented in order to procure adequate funds. The five steps to a pavement management system for the maintenance of pavements are as follows:

1. **Pavement inventory** ~ Delineate the various section of pavement in order to identify the various areas of pavement with different capabilities and use (i.e. runways, taxiways, aprons, etc.) which may need different strategies for maintenance.
2. **Pavement condition survey** ~ Survey the pavement condition and document the required maintenance for each pavement area.
3. **Project ranking** ~ Rank projects in order to assure that the most severe and the most cost-effective projects are considered first.
4. **Programming** ~ Programming and scheduling taking into account the level of funding available to do the work.

5. Implementation and Record Keeping ~ Implementation of the program and represents the feedback between maintenance needs and fiscal resources. This step also relates the program to the realized outcome (work completed) and the increase in the pavement condition.

Keeping good records is an essential part of this process. Accurate records will show how the yearly strategies are working and if in the future any changes to these strategies are needed if the desired results are not being met.

Each step of the five steps is explained in detail in the following sections.

Pavement Inventory

Using an airport layout plan map (ALP), identify and record paved areas to be included in the pavement condition survey. It may be appropriate to divide some longer airfield pavements into smaller segments with common characteristics. For large parking lots or aprons it may also be beneficial to separate the parking lots and aprons into smaller areas such as "north parking lot", "south parking apron" etc.

Pavement Condition Survey

The form shown in Figure 13-1 can be used to conduct a pavement condition survey for the various areas delineated in step 1. The inspector should take advantage of the space provided for comments to record any observation that might affect the work to be recommended. For instance, if the pavement condition is fair and appears to have deteriorated faster than would be expected due to a drainage problem, then this should be noted. In this case a plan for treating the drainage problem would be an essential part of maintaining the pavement area.

The year specified for proposed maintenance or improvements is important. The inspector should estimate the best time to perform the work and, if possible, include a comment about the alternatives. For instance, the recommendations might be to resurface in year two, with the comment that if the overlay is not in place within three years, reconstruction of the pavement and base will be required.

Figure 13-1 Airport Pavement Condition Survey Form

PAVEMENT CONDITION SURVEY	
Inspector: _____	Date: _____
Pavement Section: _____	
PAVEMENT AREA CONDITION AND CHARACTERISTICS: Check the appropriate box	
I. Pavement Condition Rating:	
<input type="checkbox"/> Excellent	Little distress. New or nearly new pavement.
<input type="checkbox"/> Good	Significant distress. Treatable with sealing and patching
<input type="checkbox"/> Fair	Moderate distress. Deteriorating rapidly.
<input type="checkbox"/> Poor	Extensive Distress. Thins overlays may be ineffective.
<input type="checkbox"/> Very Poor	Near Failure
<input type="checkbox"/> Failure	Dangerous. Requires constant repair.
II. Drainage Condition Rating:	
<input type="checkbox"/> Good	Ditches, culverts, inlets clean. Safety areas slope down away from pavement edge in all places.
<input type="checkbox"/> Fair	Interruptions to drainage such as vegetation or silt build-up causing ponding and runoff delays.
<input type="checkbox"/> Poor	Ditches are not clean, culverts, inlets clogged. Safety areas do not drain properly.
III. Degree of Oxidation of HMA Surface	
<input type="checkbox"/> Good	HMA surface does not show signs of significant oxidation.
<input type="checkbox"/> Fair	HMA surface shows signs of significant oxidation.
<input type="checkbox"/> Poor	HMA surface shows severe signs of oxidation including loosened particles.
General comments regarding observations (reference comments to I, II, or III above)	

Recommended Actions (reference to I, II, or III above)	

Year when this work should take place: _____	Estimated Cost: _____
Who will accomplish work: _____	
Action Completed (reference I, II, or III above) ~ describe action taken, by whom, expenditures, areas treated and dates:	

Project Ranking

When the pavement survey is complete and maintenance needs have been determined, the next step is to rank the recommended maintenance actions. Pavements in the poorest conditions may have the highest priority; these sections cause unnecessary wear and tear to aircraft, are expensive to maintain, and may be hazardous. Yet, the best pavement areas, those which are well built and in good condition, represent an investment, which should be

protected against normal deterioration. The following formula can be used to help determine which pavement area has priority:

$$P = PC \times (TV + HT + O) \times D$$

Where: P = priority
 HT = heavy aircraft traffic
 PC = pavement condition D = drainage condition
 TV = traffic volume O = oxidation condition

Notice this formulation requires that descriptive information from the survey form be translated into numeric values. The numeric value for the descriptive information for the *Pavement Condition*, *Traffic Volumes*, *Drainage Condition* and *Oxidation Condition* is shown in Table 13-1.

Table 13-1 Numeric Values for Descriptive Condition Rating

Condition Descriptive Rating	Numeric Value
Pavement Condition	
Excellent	1
Good	2
Fair	3
Poor	4
Very Poor	5
Failure	6
Traffic Volume and Heavy Aircraft Traffic	
Low	1
Medium	2
High	3
Drainage Condition and Oxidation Condition	
Good	1
Fair	2
Poor	3

Table 13-2 shows an example of the priority rating using the above formula.

Table 13-2 Project Priority Rating Example

Year	Pavement Area	Pavement Condition	Traffic Volume	Heavy Aircraft Traffic	Drainage Condition	Oxidation Condition	Priority Score
1	Runway	4	3	2	1	1	24
1	Taxiway	4	2	2	1	1	20
2	Apron	3	2	2	1	1	15

Programming

Having listed maintenance needs and their relative priorities within each type of maintenance project, the engineer and/or airport manager must decide where to spend the limited funds available and whether additional funds should be appropriated. First the cost of each project must be estimated. The airport manager or engineer should make a short list of unit costs for treatments used recently on similar size airports. It may be convenient to specify average unit costs for specific procedures, such as crack sealing, 1-1/2" overlays, paint markings, etc.

The Asphalt Institute has also developed a pavement rating system for low-volume asphalt

pavement areas. Information about its system is contained in **Information Series No. 169 (IS-169)**. The subject also is covered in some detail in **The Asphalt Handbook guide series No. 4 (MS-4)**.

RATING AN AIRFIELD PAVEMENT AREA ~ Pavement Condition Index

The Asphalt Institute's publication and others provide a system for any individual or agency to inspect a pavement, rate it, and interpret the results. What is needed is an individual or individuals with maintenance knowledge - such as a qualified engineer, or an airport operations manager - to walk the pavement and assign a numerical value to each type of pavement defect. The type of distress, the extent of the distress, and its relative seriousness should be recorded. In this procedure, lower values are assigned to less serious problems and higher values to more serious problems. A rating of zero indicates that the pavement is relatively free of defects. A rating of five or ten would indicate serious distress. After each defect has been rated, the individual ratings are added. The sum is then subtracted from 100 and the result is a Pavement Condition Index (PCI) for that particular section of pavement being evaluated. A rating form that can be used is shown in Chapter 11, Figure 11-4. This form or one similar to it could be used in rating the pavements on a routine basis.

Remember, it is important that pavements be evaluated in a consistent manner. Personnel conducting a condition rating survey should have knowledge of the various types of defects, their cause, and the remedial action required. A procedure for troubleshooting and identifying pavement failures is included in Chapter Fourteen of this Guide. Additional detailed information on this subject is available in The Asphalt Institute's publications **(MS-16)**, **(MS-17)**, **(MS-4)**, and from the **"Distress Identification Manual for the Long-Term Pavement Performance Project"**, a Strategic Highway Research Program (SHRP) publication, SHRP-P-338. This manual can be used as a guide to help the raters in their evaluation. Color photographs and drawings illustrate the distresses found in pavement. Drawings of the distress types provide a reference to assess their severity. Methods for measuring the size of distresses and for assigning severity levels are given. Although the manual is for roadway evaluation, distresses in airport pavements are similar. The manual also tells how to calibrate and operate profile and fault measurement devices. This manual (SHRP-P-338) can be obtained through the Federal Highway Administration. A procedure for troubleshooting and identifying pavement failures is included in Chapter Fourteen of this Design Guide. Additional detailed information on this subject is available in The Asphalt Institute's publications **(MS-16)**, **(MS-17)**, **(MS-4)**, and others.

Colorado Division of Aeronautics conducts Airport PCI (Pavement Condition Index) surveys regularly and maintains computer records of the distresses and numeric PCI ratings of pavement areas. To insure the accuracy of the process, they need to input information on maintenance and rehabilitation. Access to airport pavement management records will assist their efforts.

INTERPRETATION OF A CONDITION RATING

Airport PCI information as compiled by the Division of Aeronautics is available to airports for use in pavement management. Assistance in interpretation of PCI data is available from the Division or from consulting engineers.

The absolute value assigned by the condition rating provides an indicator of the type and degree of repair work necessary. As a general rule, if the condition rating is between 80 and 100, normal maintenance operations (crack-filling, pothole repair, or seal coat) are required. If the condition falls below eighty, it is likely that an overlay will be necessary. If the condition rating is below thirty, major reconstruction may be necessary as shown in Figure 13-3.

Another valuable use for the condition rating is to provide a rational method for ranking pavement areas according to their condition. A priority ranking should be the basis for programming and budgeting maintenance, rehabilitation, and reconstruction. It should be noted that the FAA typically ranks runway pavements as having the highest priority followed by taxiway pavements and aircraft parking aprons.

PAVEMENT MAINTENANCE

Figure 13-3 Suggested Zones for Maintenance and Rehabilitation Strategies

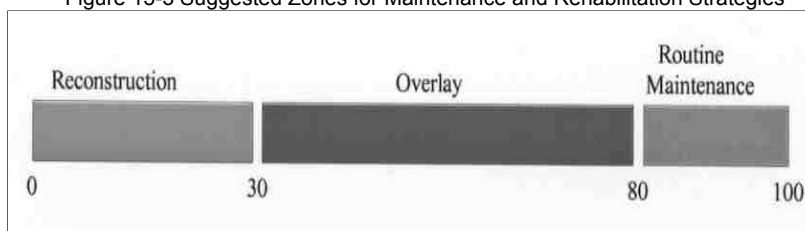

Pavement maintenance is the work performed to keep a pavement, which is exposed to normal conditions of traffic and nature, as near to its original condition as possible. Because destructive environmental and traffic forces are constantly at work, pavements require maintenance. Cracks, holes, depressions, and other types of distress are the visible evidence of pavement wear.

Because of a limited amounts of traffic (aircraft) on airport runways, taxiways, and parking aprons, load related distresses are minimal. Oxidation (drying due to the sun's ultraviolet rays) of the HMA pavement surface is much more severe than for highways. Accordingly, the airport HMA pavement surface needs to be fog sealed more often than roadways, highways or parking lots for automobiles.

Taking care of pavement deterioration at the proper time and in the proper manner can significantly increase the life of the pavement. Early detection and repair of minor defects are among the most important activities of a pavement maintenance crew. In their first stages, cracks and other surface breaks are almost unnoticeable, but they may develop into serious defects if not soon repaired. Open joints and cracks allow water to enter the subgrade and can lead to pumping and faulting which results in structural failure. Drainage is a major concern because of the relatively large flat surface areas of airport pavement.

Pavement maintenance involves the identification of pavement distress types and the determination of appropriate maintenance activities.

PAVEMENT MAINTENANCE STRATEGIES

Routine Corrective Maintenance - For pavement areas in reasonably good condition, routine maintenance is generally the most cost-effective use of funds. If at all possible, routine maintenance needs should be funded each year. Routine maintenance usually includes local patching, crack sealing and other relatively low-cost actions. Distresses with negative impact

on the performance of a section are usually corrected first; i.e. pot holes.

Preventive Maintenance - This strategy is a more expensive activity designed to arrest deterioration before it becomes a serious problem. Surface seals are excellent examples of preventive maintenance. A common source of poor performance of seals is adequate repair of existing distress. Repair and seal needs may have to be programmed over several years in order of priority because of costs. Routine maintenance should be performed on those sections that are not programmed for reconstruction in the current budget year. State aeronautics is often a source of funds for this type of maintenance.

Deferred Action - The pavement areas which fall into this category receive minimum funds for the current budget year. These sections are beyond the point where preventive maintenance will be effective but have not yet deteriorated to the point of needing rehabilitation. Selecting this strategy is deferring action, so an agency must be prepared to fund rehabilitation or reconstruction when it becomes necessary. This strategy is normally not appropriate for higher speed pavement areas.

Rehabilitation - Rehabilitation usually includes overlays or extensive recycling. Funding for completion of these major projects may depend upon federal (FAA), State Department of Aeronautics or other outside sources. The established priorities should be followed if possible, although managers should realize that priorities may change for a variety of reasons. For example, estimates for a particular job may exceed available funds, insurmountable administrative restrictions on funds may exist, or very valid political reasons to change priorities may occur. Sections that fall into this strategy category that are not programmed for the current budget year should fall into the deferred action strategy.

Reconstruction - The comments on rehabilitation projects also apply to reconstruction projects. The main difference is in the costs that might be expected. Reconstruction would involve complete removal and replacement of a failed pavement such as widening, relocation, expansion, safety area and major drainage work. Lead times of five to ten years might be required because of the significant nature of required investments and the time necessary to develop plans, acquire land and other funding.

Table 13-3 provides asphalt pavement maintenance alternatives along with comments about performance.

Table 13-3 Maintenance Alternatives

Treatment	Comments of Performance
Fog Seal Diluted emulsion	Renews and enriches oxidized surface; seals minor cracks; prevents raveling; provides shoulder delineation. The emulsions use for fog seals can be Gilsonite and Polymer modified. Reclaiming and rejuvenating emulsions can also be used. Coal Tar sealers should <i>only</i> be used on refueling areas.
Sand Seal About 3/16" thick	Generally this is the lowest initial cost type of sealing coating application, it seals only and does not add structural strength, does not level, smooth or correct crown significantly unless pre-leveling is done first. The average service life is 3-6 years. The main advantage is that it can be done with local labor and sometimes aggregate. Castings are not generally adjusted. Application is not appropriate for grooved runways or heavy aircraft traffic areas.
Slurry Seal Coat Single 1/8" thick = 25 lb./sq. yd. (A specialty contractor must apply it.)	Moderate to higher initial cost application due to full contract required. Main advantage quicker, neater application. Castings generally do not need adjusting; should be applied in good, low humidity weather. Average life, single application 3-5 years, double application 5-8 years. Provides smooth, tight surface similar to hot mix. Good for low and moderate volume pavements. Not recommended for grooved runways.
Aggregate or Chip Seals 3/8" thick 3/8" - 1/2" Chips 33 to 45 lb./sy. yd.	<i>Usually appropriate for small aircraft facilities only.</i> If used on heavier traffic airport with jets, should be covered with a heavy fog seal so loose chips can not be sucked into engines. Low to moderate initial cost depending on local labor and aggregate sources. Castings generally are not adjusted. A good chip seal provides excellent skid resistance and provides attractive color by choice of stone. The average life is 5 to 8 years.
Plant Mix Seal Coats - Thin Hot Mix Overlay high quality, thoroughly controlled hot mixture of asphalt cement and well-graded, high quality aggregate, thoroughly compacted into a uniform dense mass.	The higher cost thin hot mix overlays (less than 1" thick) are also considered as sealing treatments primarily and not structural improvements. They also smooth the surface quite a bit. Very rough surfaces need to be pre-leveled or mix will apply poorly and mat will have to be thickened. Thinner treatments used on lower volume pavement areas in better shape, thicker treatments on higher volume pavement areas and rougher surfaces. Multiple treatments if applied in timely stages can add strength. Care must be taken; these relatively stiff treatments are not put on pavement areas that need of significant structural upgrading as large deflections will cause the surface to crack. The average life is 6-12 years.
Structural Overlay - Thick Hot Mix 1-1/2" - 2" thick = Structural overlay and also seals. Probably the most common Rehabilitation treatment. (Recommended minimum two inch overlay).	1-1/2" to 2" overlay not only seal but adds significant structural capacity (depending on existing thickness). It seals, smoothes the ride and corrects crown and drainage features substantially. Extra rough pavement areas may require pre-leveling prior to overlay. This treatment is the highest form of maintenance and upgrading treatment for low volume pavement areas and is the most expensive of treatments listed here. Average life is 15-20 years on high volume pavement areas, longer on lower volume pavement areas.

CRACK SEALING

WATER IS THE MOST DESTRUCTIVE element to pavement. Asphalt pavements expand and contract with seasonal temperature changes. Consequently, cracks and joints are expanding and contracting when the pavements move. Sealing the cracks with a flexible rubberized asphalt that bonds to the crack walls and moves with the pavement will prevent water intrusion. Simply stated, sealing cracks and joints in pavements extends the service life of the surface treatment and the pavement. In fact, pavement areas that have been crack sealed have better rideability five years later than those receiving only surface treatments, such as chip seals, micro-paving, thin overlays and slurry seals. In five years these other treatments have come to the end of their life cycle. Crack sealing treatments enhance the surface treatment and further extend the pavement life. Crack sealing provides the most cost-effective use of dollars over time compared to other pavement maintenance techniques.

To ensure a minimum standard for sealant performance, the American Society of Testing and Materials (ASTM), the American Associations of State Highway and Transportation Officials (AASHTO) and federal airport authorities have developed test specifications for polymer-modified and asphalt rubber sealants. Today's sealants are highly engineered products formulated to perform in some of the most difficult climatic conditions. The ability to produce a material that will not be soft and track in the summer and still be flexible in freezing temperatures requires research.

Using the right equipment is an important part of any crack sealing program. There are two major areas of consideration: 1) crack preparation and sealant application, and 2) cracks must be free of dirt, dust and debris. The sealant must have a clean, dry bonding surface.

Surface Preparation

Surface preparation can be accomplished with compressed air and a simple blow pipe. This technique works well when the dirt is dry and not packed hard. If the cracks are filled with wet dirt, the dirt needs to be removed and the crack must be completely dried. In this case an a hot air lance generating temperatures in excess of 2,000 °F is the best tool. In simple terms, a heat lance uses hot, compressed air to blow cracks clean while drying them out. Also the use of a router to enlarge small cracks so a consistent, uniform reservoir for sealant is obtained. Results from A SHRP study showed there is almost a forty percent greater chance of sealant success if cracks are routed prior to sealing. (Note: Older-aged asphalt pavements and thin asphalt pavements may not be suitable for routing.)

Although roofing tar pots are still used for applying mineral-filled materials, they will burn or destroy crack and joint sealants that utilize polymers or rubber. Melters eliminate this problem by using a high-temperature heat-transfer medium, such as oil. These types of melters are known as "oil jacketed" melters or "double boilers". Hot pour sealants are effectively applied through a delivery hose and wand. These materials are commonly applied at 375 °F. To prevent sealant cooling, set up and clogging, the hose is placed under constant pressure and the sealant constantly circulates back into the main tank. Crew members therefore must be trained not only in proper safety procedures but also in proper operation of the melter.

Sealant Application

The sealant can be placed flush with the pavement, slightly below the surface of the pavement or slightly above the Surface. In an overband configuration, the sealant is placed onto and over an un-routed crack. The Sealant can be shaped into a band over the crack using a rubber blade squeegee or a sealing shoe that flattens the sealant over the crack. When a pavement is to be overlaid shortly after crack sealing, an overband configuration is not recommended because the extra crack filler will cause problems with the overlay. When an overlay is to follow crack filling, the crack sealant should be struck off flush with the pavement surface. A leveling or scratch coat of HMA should be planned for, or the overlay should be postponed for 6-12 month for the crack filler material to cure and stabilize.

Pavement selection is often the forgotten element in determining the success of failure of a sealant program. If the pavement section has alligator cracking, high-density multiple cracking, poor sub-base drainage or structural damage, crack sealing will not solve the problem. In these cases the damage is too severe. If you try to save a pavement with too much cracking, you will be disappointed with your efforts. The best candidates for crack sealing are newer pavements that are beginning to form cracks. You certainly can extend the life of these

pavement areas. More sealant is not always better. The new sealants are not designed to be "road glue". They are very sticky and have tremendous bonding power, but they are not made to "hold the road together". Crack sealing has one objective: to prevent water flowing into and under the pavement layer to prevent further damage to pavement areas. Sealing buys time and saves money by delaying the expense of major reconstructive pavement work.

FULL DEPTH HOT MIX ASPHALT (HMA) PATCHING

The full-depth HMA patch is an important maintenance technique for protecting and preserving the sizable investment in pavement areas. It is used to repair all types of localized pavement distress that extend below the pavement area surface. Examples include potholes, alligator cracking, upheaval, and shoving.

The procedure is intended to remove the failed area and replace it with fresh HMA mix. Although the operation is not difficult, some of the necessary fine points are frequently not given sufficient attention. Yet these details often determine whether the completed patch will be a temporary expedient or an integral part of a functional pavement system.

The following ten steps outline the correct procedure for constructing a full-depth patch:

1. Cut the outline of the patch, extending at least one foot outside of the deteriorated area. The outline should be square or rectangular with two of the sides at right angles to the direction of traffic.
2. Excavate as much pavement as necessary to reach firm support. If a patch is to be an integral part of the pavement, its foundation should be as strong as or stronger than that of the original pavement area. This may mean that some of the subgrade will also have to be removed. The faces of the excavation should be straight and vertical.
3. Trim and compact the subgrade.
4. Apply a tack coat to the vertical faces of the excavation. Emulsified asphalts or liquid asphalt are suitable.
5. Backfill with the asphalt mixture. Shovel the mixture directly from the truck into the prepared excavation. Place the mixture against the edges of the hole first (rather than in the center and then raking to the edges). The maximum lift thickness largely depends upon the type of asphalt mixture and the available compaction equipment. Hot mix asphalt can and should be placed in deep lifts, because the greater heat retention of the thicker layers facilitates compaction. From a compaction standpoint, patches using hot mix asphalt can be backfilled in one lift. However, when placing a patch that is deeper than 5 inches, it is often useful to leave the first lift 1 to 2 inches below the finished grade, making it easier to judge the total quantity of mixture required for the patch.
6. Spread carefully to avoid segregation of the mixture. Avoid pulling the material from the center of the patch to the edges. If more material is needed at the edge, it should be deposited there and the excess raked away. The amount of mixture used should be sufficient to ensure that after compaction, the patch surface will not be below that of the adjacent pavement. On the other hand, if too much material is used, a hump will result.

7. Compact each lift of the patch thoroughly. Use equipment that is suited for the size of the job. A vibratory plate compactor is excellent for small jobs, while a vibratory roller is likely to be more effective for larger areas.

8. When compacting the final lift (which may be the only lift), overlap the first pass with the second pass about six inches with the vibratory roller or plate compactor. Then move to the opposite side and repeat the process. Once this is accomplished, proceed at right angles to the compacted edges with each pass and return, overlapping a few inches on the uncompacted mix. If there is a grade or slope, compaction should proceed from the low side to the high side to minimize possible shoving of the mix.

9. When adequate compaction equipment is used, the surface of the finished patch should be at the same elevation as the surrounding pavement. However, if hand tamping or other light compaction methods are used, the surface of the completed patch should be left slightly higher than the adjacent pavement as the patch is likely to be further compressed with traffic.

10. Check the vertical alignment and smoothness of the patch with a straight edge or string line.

HOT MIX ASPHALT (HMA) OVERLAYS

As discussed earlier under pavement management concepts, the condition rating provides a rational method for evaluating the need for an overlay. If the condition rating falls below 80, it probably calls for an overlay. Deferring the overlay allows further deterioration of the pavement. At some point in time, the life of the pavement is severely affected, which will increase costs significantly.

The predictive capabilities of a pavement management system allow an agency to analyze alternative programs and select a maintenance strategy that is cost effective. Deferred maintenance is more costly in the long run as illustrated by the quality of deterioration over time example.

Hot Mix Asphalt (HMA) is an excellent resurfacing material that is equally effective for overlaying asphalt/aggregate surfaces, HMA pavements, or Portland cement pavements. HMA overlays add strength to an old pavement structure, extend service life, and provide a smooth, skid-resistant pavement. They improve riding quality, cross section, and they increase a pavement's resistance to water intrusion and de-icing chemicals. The result is a better riding surface and a stronger pavement than the original.

ADVANTAGES

An HMA overlay offers the following advantages:

1. Convenience. The pavement may remain in use while it is being upgraded.
2. Economy. An old pavement frequently may be improved and returned to service more quickly and for less cost than a new road can be constructed.

3. Durability. Well-designed, well-constructed improvements provide a pavement that is stronger than new, which reduces maintenance requirements.

DESIGN CONSIDERATIONS

Each resurfacing project should be designed on an individual basis. Before constructing an HMA overlay, careful and correct preparation of the existing pavement is essential for maximum pavement performance.

Local Repairs ~ Weak areas should be repaired. Structural patches should be designed and constructed with full-depth HMA to ensure strength equal to or exceeding that of the surrounding pavement. Carefully placed and adequately compacted patches will produce uniform support for the overlay and ensure good performance

Structural Deficiencies ~ Pavement deficiencies that do not affect structural adequacy are usually corrected by thin resurfacing using thicknesses selected from experience. Weakened pavement structures call for overlays of designed thicknesses that will sufficiently strengthen the pavement structure to accommodate the traffic expected to use it.

Drainage ~ Older pavements may show signs of fatigue because of intrusion of groundwater from below or from surface water entering along the edge between the pavement and the shoulder. This water should be removed by under drains or by other means several weeks before constructing the HMA overlay.

Leveling ~ When the surface is distorted, the construction of leveling courses or wedges is required to restore proper line and cross section.

Overlay Thickness ~ HMA overlays may be used to correct both surface and structural deficiencies. Present pavement condition and estimates of future traffic influence appropriate thickness of these overlays. If a pavement has failed by plastic deformation, evidenced by rutting and shoving, the depth of the failed area should be identified and removed by milling prior to placement of an overlay. A two-inch average depth of HMA surface should be the minimum thickness. As a standard rule, the lift thickness should be at least twice the maximum aggregate size in the mixture.

OVERLAY THICKNESS CALCULATIONS

To calculate the thickness of an overlay following factors need to be determined:

- Strength of the subgrade (CBR or R Value).
- Thickness and density of the existing pavement section to be left in place.
- Strength coefficients for each material within the pavement section to be left in place.
- Up to date, realistic aircraft loading and equivalent annual departures for the design life of the new pavement section.
- An appropriate regional factor.
- Using the Nomographs from Chapter Three, a revised, weighted structural number can be determined.
- The thickness of the overlay required for the adjusted traffic requirements can be determined using the same criteria outlined in Chapter Three.

Adequate preparation of the existing pavement prior to an HMA overlay is important. When repairs are completed, the surface to be overlaid should be thoroughly cleaned. Then a tack coat of asphalt should be applied to ensure uniform and complete adherence of the overlay.

CHAPTER FOURTEEN

TROUBLESHOOTING AND PAVEMENT FAILURE IDENTIFICATION

CHAPTER FOURTEEN

TROUBLESHOOTING AND PAVEMENT FAILURE IDENTIFICATION

GENERAL CONSIDERATIONS

Potential problems, if left uncorrected, will lead to premature asphalt pavement failure. Most of these problems are identifiable and correctable during construction and/or just before the start of paving. To accurately identify asphalt pavement failures after placement is completed requires a systematic approach that includes informal visual procedures in conjunction with more formal forensic procedures.

PRIOR TO PAVING

Before the start of paving most potential problems can be identified and addressed. These problems should be reviewed during design and at the pre-bid meeting. The remainder of the potential problems should be addressed at a pre-paving meeting. It takes a combined team effort to address the problems that could go wrong and result in premature failure of an asphalt pavement. Some key issues to consider are as follows:

- **Asphalt pavement section** - Is it based on a design that reflects the actual field conditions and loading requirements? During the initial stages of construction the designed pavement section should be reviewed to verify that actual site conditions have been correctly anticipated. Such things as unknown subgrade problems, higher than anticipated water tables, drainage problems, and utility conflicts are just a few of the things that may require design modifications. Care should be taken to make sure that construction traffic does not exceed the design traffic ESALs.
- **Job mix formula** - Has the job mix formula for the HMA for the project been submitted for approval and is it in compliance with the project specifications? Are the HMA specifications correctly chosen for the class of roadway, traffic and climatic conditions? The use of "Canned" specifications can lead to premature pavement failures because they are sometimes not appropriate. Everyone should agree that the mix chosen and specified for the project is the correct mix. It is not too late to suggest a different binder or mix design.
- **Compaction test** - A review of compaction test results for utility trenches, backfill, subgrade reconditioning, subbase and base course will identify deficiencies that may need to be corrected prior to paving.
- **Final grade verification** - Final grade of the surface to be paved on, manhole rings and valve boxes need to be verified. Also is there adequate compaction at or adjacent to manholes, risers, curb faces, etc.
- **Final proof rolling** - A final proof rolling check of the subgrade and base course should be performed shortly before paving.

DURING PAVING

At the start of paving, a test section should be placed so that job mix properties can be verified and fine tuning of the mix and construction procedures (equipment, rolling techniques, and patterns etc.) can be made. The test section should be of sufficient quantity so that the hot plant can "level out" and produce consistent material. It is recommended that a test section should be at least 300 ton of mix placed on similar surfaces and conditions as will be experienced on the project. Testing of the mix should consist of at least three and preferable five random samples. The following properties should be measured during the test section:

1. Asphalt content
2. Gradation
3. Volumetric Properties
 - A. Air Voids
 - B. VMA
 - C. Voids filled with asphalt
4. Strength measurements (if appropriate)
 - A. Marshall Stability
 - B. Hveem stability
5. Stripping potential of mix
 - A. Lottman TSR values
 - B. Immersion Compression test results
 - C. Rutting potential
6. In place compaction (calibrate nuclear gauges to cores)
7. In place air voids

After testing, (based on construct-ability properties of the mix placed during the test section) modifications and fine tuning of the mix should be made. If it is necessary to make major changes a new test section may be required. In extreme cases it may be necessary to re-do the job mix formula and start over.

In residential and commercial paving the test section can be eliminated for small projects provided there is already available information from prior projects to verify the mix properties and performance criteria.

SEGREGATION

Hot Mix Asphalt is a mixture of graded aggregate and asphalt cement designed to provide both strength and durability. It is unique in that it is also flexible, making it adaptable over a wide range of climatic conditions.

Considerable effort has been exerted over the last decade to improve the performance of HMA through better combinations of grading, the addition of polymers, fibers, and various other products. These products are intended to reduce rutting, add to durability, and lead to a longer life of the pavement. In order to ensure pavement performance, the HMA must be mixed, stored, transported, and placed uniformly and with the same gradation the lab designed. At each point during the manufacturing process from stockpiling, aggregate blending, mixing, conveying, storing, truck loading, and placement at the paver, the mix has an opportunity to segregate, creating non-uniform mixes. A segregated spot may be "the birth of a pothole."

When segregation is present in a mixture, there is a concentration of coarse materials in some areas of the paved mat, while other areas contain a concentration of finer materials. Segregation creates non-uniform mixes that do not conform to the original job mix formula in gradation or asphalt content. The resulting pavement exhibits poor structural and textural characteristics, provides poor performance and durability, and has a shorter life expectancy and higher maintenance costs.

Problems associated with segregation are serious. Their elimination is essential to the production of high quality paving mixtures. Elimination of segregation is the responsibility of those who produce and place HMA, organizations who design the mix, owners who inspect the final product, and manufacturers who design and market paving equipment.

There are five basic types of mix segregation that occur on the road. The five types of segregation are:

- a) Truck end segregation
- b) Center line segregation
- c) Joint/edge segregation
- d) Truck end/edge segregation
- e) Random segregation

The different types of HMA segregation can be identified and prevented. The "Segregation Diagnostic Chart" in the appendix will aid in the determination and correction of the segregation problem.

AFTER PAVING

Unfortunately, occasionally after completion of paving (and sometimes a year or two later) pavement distress occurs. When this happens, a systematic method of sampling and testing should be followed to identify the cause of the HMA pavement failures. Based on the type and degree of the failure, the appropriate investigation should be performed based on the following procedures:

PROCEDURE FOR EVALUATING PLANT MIX SURFACING FAILURES

This method covers the step-by-step procedure for evaluating a HMA pavement failure. The procedure calls for reviewing the types of plant mix failures and a method for rating the distressed areas. It is recommended that a review team be appointed consisting of:

- A civil engineer familiar with the design,
- A contractor representative that knows how the project was built,
- A consultant familiar with asphalt mixes, experience in construction methods and techniques as

- well as pavement failures in general; and
- A representative of the testing firm involved in the project.

After determining the type and extent of the failure, further investigational requirements may include reviewing plant mix production records, visual analysis, deflection analysis, sampling analysis of plant mix, base and subgrade materials and surfacing design analysis. Based upon the information and data gathered through this procedure, the causes, potential solutions and recommendations to correct the plant mix surfacing failures can be determined.

The evaluation and analysis of the failure may cease at any time in the process when both parties agree to the source of the causes and a suitable remedy and the cost basis of responsibility has been identified.

VISUAL ANALYSIS

The first step in investigating a pavement failure is to perform a complete and comprehensive visual analysis of the entire project emphasizing the distressed areas in question. The approximate milepost and/or stationing and length of each of the distressed areas should be determined.

The following table is a list of pavement distress types and a rating system which can be used for the evaluating the pavement failure.

Table 14-1 Pavement Failure Rating System Rating

Failure Type	Severity of Failure		
	Light	Moderate	Severe
Rutting ¹			
Rut depth	0 to 1/2"	1/2 to 3/4"	> 3/4"
Rate of Rutting	0 to 1/8"/year	1/8 to 3/8"/year	> 3/8"/year
Lateral Movement of Ruts (Humping or shoving)	None Visible		Visible bulge
Cracking	Longitudinal cracks in wheel paths (Load associated)	Alligator or block cracking - tight	Alligator or block cracking edges spaced - pieces loose or missing
Stripping ²	Some asphalt material stripped	Cores ³	Cores ³
Raveling	Fines removed from surface	1 st layer coarse aggregate removed	Pavement removed through one or more lifts
¹ If single or dual wheel ruts exist, they should be noted. Measurements should always be taken in each wheel-paths with a string-line stretched from centerline to the shoulder or from high point to the next if centerline to shoulder is not possible to obtain the measurements. ² Any stripping should be noted. ³ If the investigation requires plant mix cores, advanced stages of stripping will be determined at that time.			

VISUAL ANALYSIS REPORT

A summary of the visual analysis should be written immediately after the investigation. It is suggested the consultant prepare the written report of the investigation and evaluation, for he should not have any direct ties to the project.

The report should include date, reviewer, project limits, and detailed information concerning each distressed area. This information should include but not be limited to approximate milepost or station, length, width, relationship to centerline, lane and type of distress. Also, photographs of the typical distress on the project should be included. In addition to recording the types of pavement distress referenced above, record any other problems that are visible (drainage, terrain, frost problems, dips or swells, etc.). Based upon this visual analysis, the course of action and investigational requirements can be determined. Copies of the report shall be sent to the review team for review and analysis.

INVESTIGATION REQUIREMENTS

Determine the investigational requirements depending on the type and extent of the plant mix failure. Table 14-2 is a list of the distress types with the corresponding investigation requirements that should be included in the determination of the pavement failure. Table 14-3 shows what type of data and test are required for the different distress types.

Table 14-2 Investigation Requirements for Various Distresses

Distress Type	Investigation Required ¹
Cracking- Alligator	1 thru 7
Rutting & Shoving	1 thru 7
Stripping – Underlying Courses	1 thru 7
Raveling – Surface	1,3,4
Segregation	1,3,4

¹ Descriptions of the Investigation Requirements are shown in Table 15-3

Table 14-3 Required Data for Distress Investigation

Investigation Requirements	Data Required
1. Physical Data (Information already obtained)	Location Weather Extent of failure Photos
2. Deflection Analysis (If information is available)	Road Rater Testing Evaluate good and bad areas of Project, Deflection analysis only applies to large projects.
3. Production Records (A review of construction reports) When reviewing the reports listed below, look for any abnormalities. Example: The production records generated during construction should be reviewed to determine if any problems during construction can be related to the pavement failure. For example, there may have been some density problems in the same area of the failure, late paving, etc.	Mix Designs Plant Records Physical Properties Test (of mixture) Aggregate Tests Compaction Tests Binder Tests Monitor Samples Project Diaries
4. Core Samples (Plant mix core samples shall be obtained and tested) Lifts will be identified and tested separately.	Thickness Density Rice Gravity A.C. Content Extraction and Abson Extraction - AC Penetration & Viscosity Petrographic - Geology Other tests to be determined at the time of testing
5. Sampling In-Place Subbase or Base Material	R-Value or CBR Liquid Limit Moisture Gradation Proctor
6. Traffic Data	Present EDLA Accumulative EDLA
7. Structural Properties	Pavement Section Evaluation by a qualified traffic engineer

SAMPLES AND TESTING

Samples shall be taken so that the following tests and procedures can be run to evaluate the problem areas. The samples should be submitted to an agreed upon AASHTO accredited laboratory.

Samples shall be taken of each plant mix layer with at least 5 - four inch diameter cores from a bad area, a shoulder next to bad area, and a good area. A suggested coring scheme is shown in figure 14-1. If more than five distressed areas exist on a project, the minimum number of sample locations will be three, if the distressed areas appear to be visually identical. If the lifts are still intact and hard to separate they should be separated using a wet diamond blade saw. Each lift of plant mix shall be evaluated for:

- Rice Gravity

- Density
- Thickness - Each core should be measured
- Extracted Gradation
- Extracted Percent Asphalt
- Absorption Extraction - Asphalt Penetration & Viscosity
- Petrographic-Analysis (geology)

Figure 14-1 Typical Coring Scheme

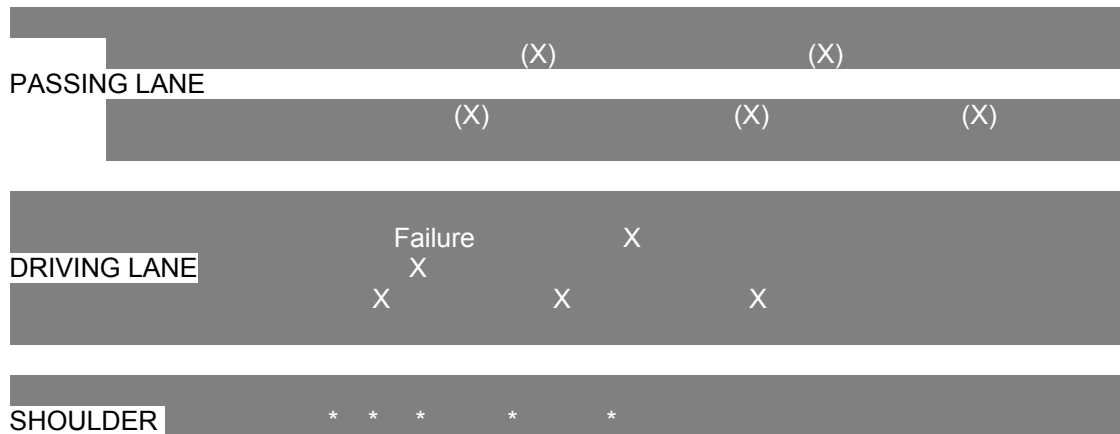

X - -Samples within area of visible failure
 * - -Samples within same paver pass but not visible failed
 (X) - -Samples from good area

Base and Subgrade ~ When obtaining samples of the base and subgrade materials, a minimum three by three foot area of plant mix shall be taken in the wheel path at each location. This should allow for adequate testing and sampling of each lift of material. The following test and procedures should be run on the samples taken:

- In-place densities and moisture shall be obtained for each lift using a nuclear gauge.
- In-place moisture samples shall be taken of each lift and immediately placed in a sealable plastic sack. The sample size shall be a minimum of one pound (450 grams). These samples shall then be oven dried to obtain a moisture content.
- A minimum of two R-Values or CBR samples shall be taken from both the base and subgrade for a given problem area. In addition, one sample per mile shall be taken for the remainder of the project. The sample size will be appropriate for the tests to be performed.
- Samples and thickness of each subgrade or base lift shall be taken immediately and placed in a sealable plastic bag for soils classification, plastic index and liquid limit in accordance with CDOT, AASHTO, or ASTM procedures.

- Samples of the base and subgrade shall be taken for a proctor test to establish the optimum moisture and density. The sample size shall be determined appropriately for the tests to be performed.

Traffic Data ~ Traffic data will be requested from the design engineer or owner. This data will be used to determine if any structural deficiencies exist. If the traffic data appears to be in error, a site-specific investigation should be conducted.

Structural Analysis ~ Pavement Section Design. Either the civil engineer or materials consultant will check the design of the problem area based on the new "R" or CBR Values and the condition of the pavement structure in-place.

Report ~ A summary of the sample tests and other investigational requirements will be submitted upon completion of testing and analysis. Recommendations for repair of the failed area and estimated costs thereof will also be made.

TROUBLESHOOTING GUIDE

The **National Asphalt Pavement Association (NAPA)** has published a troubleshooting guide that lists various HMA problems and their possible causes along with possible solutions for correcting the problem. A copy of the NAPA guide "**Construction Quality Hot Mix Asphalt Pavements**" is included in the appendix. An other aspect of the guide is that when discussing problems with the people involved in the construction and rehabilitation of the pavement, can be speaking on the same terms.

APPENDIX A

Asphalt Binder Grade Selection

APPENDIX A

ASPHALT BINDER GRADE SELECTION

A1 Chapter 5 ~ Asphalt Institute's *Performance Graded Asphalt Binder Specification and Testing*, SP-1

Contrary to the previous grading systems, the Superpave binder specification is theoretically based directly on performance rather than on empirical relationships between basic physical properties and observed performance. Performance graded binders are selected based on the climate in which the pavement will serve. Unlike other systems, the physical property requirements are constant among the performance grades. The distinction among the various binder grades is the specified minimum and maximum temperatures at which the requirements must be met. For example, a binder classified as a PG 58-34 means that the binder will meet the high temperature physical property requirements up to a temperature of 58°C and the low temperature physical property requirements down to -34°C. Table 5.1 lists the current binder grades in AASHTO MP1:

Table 5-1 Superpave Binder Grades	
High Temperature Grades (Degrees C)	Low Temperature Grades (Degrees C)
PG 46	-34, -40, -46
PG 52	-10, -16, -22, -28, -34, -40, -46
PG 58	-16, -22, -28, -34, -40
PG 64	-10, -16, -22, -28, -34, -40
PG 70	-10, -16, -22, -28, -34, -40
PG 76	-10, -16, -22, -28, -34
PG 82	-10, -16, -22, -28, -34

Even with binder grades classified according to high and low temperature categories; more information is needed to select a binder for a particular location. A module within the Superpave computer program assists users in selecting binder grades. The Superpave software contains three methods by which the user can select an asphalt binder grade:

Geographic Area: An agency would develop a map showing binder grade to be used based on weather and/or policy decisions.

Pavement Temperature: The designer determines design pavement temperature.

Air Temperature: The designer determines design air temperatures, which are converted to design pavement temperatures.

The Superpave software assists in the third method by providing a database of weather information for 6092 reporting weather stations in the US and Canada that allows users to select binder grades for the climate at the project location. For each year that these weather stations have been in operation, the hottest seven-day period was identified and the average maximum air temperature for this seven-day period was calculated. SHRP researchers selected this seven-day average value as the optimum method to characterize the high temperature design condition. For the years of operation, the mean and standard deviation of the seven-day average maximum air temperature have been computed. Similarly, the one-day minimum air temperature of each year was identified and the mean and standard deviation of all the years of record was calculated. Weather stations with less than 20 years of operations were not used.

However, the design temperatures to be used for selecting asphalt binder grade are the pavement temperatures, not the air temperatures. For surface layers, Superpave defines the high pavement design temperature at a depth 20 mm below the pavement surface, and the low pavement design temperature at the pavement surface.

Using theoretical analyses of actual conditions performed with models for net heat flow and energy balance, and assuming typical values for solar absorption (0.90), radiation transmission through air (0.81), atmospheric radiation (0.70), and wind speed (4.5 m/sec), this equation was developed for the high pavement design temperature:

$$T_{20\text{mm}} = (T_{\text{air}} - 0.00618 \text{ Lat}^2 + 0.2289 \text{ Lat} + 42.2)(0.9545) - 17.78$$

Where $T_{20\text{mm}}$ = high pavement design temperature at a depth of 20 mm

T_{air} = seven-day average high air temperature

Lat = the geographical latitude of the project in degrees.

The low pavement design temperature at the pavement surface is calculated as a function of the low air temperature using the equation:

$$T_{\text{surf}} = 0.859 T_{\text{air}} + 1.7$$

Where T_{air} = 1-day minimum air temperature

The Superpave system allows the designers to use reliability measurements to assign a degree of design risk to the high and low pavement temperatures used in selecting the binder grade. As defined in Superpave, reliability is the percent probability in a single year that the actual temperature (one-day low or seven-day average high) will not exceed the design temperatures. A higher reliability means lower risk. For example, consider summer air

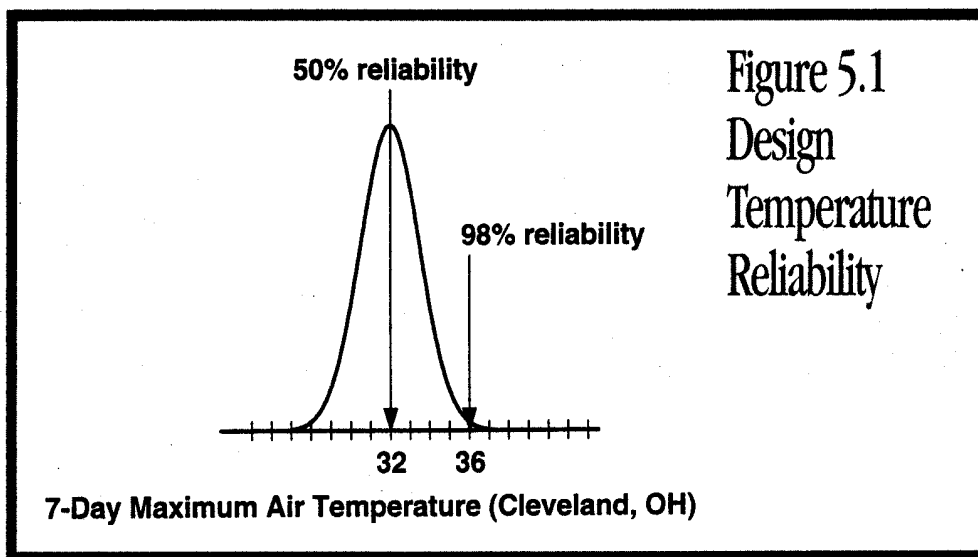

Figure 5.1
Design
Temperature
Reliability

Air Temperature Selection

temperatures in Cleveland, Ohio, which has a mean seven-day maximum of 32°C and a standard deviation of 2°C. In an average year, there is a 50 percent chance that the seven-day maximum air temperature will exceed

32°C. However, assuming a normal statistical frequency distribution, there is only a two percent chance that the seven-day maximum will exceed 36°C (mean plus two standard deviations); therefore, as shown in Figure 5.1; a design air temperature of 36°C will provide 98 percent reliability.

Continuing the example, assume that an asphalt mixture is to be designed for Cleveland. Figure 5.2 graphically represents the statistical variation of the two design air temperatures. In a normal summer, the average seven-day maximum air temperature is 32°C and in a "very hot" summer, this average may reach 36°C. Using a similar approach for winter conditions, Cleveland has an average minimum air temperature of -21°C with a standard deviation of 4°C. Consequently, in an average winter, the coldest temperature is -21°C. For a "very cold" winter, the air temperature may reach -29°C. The standard deviations show there is more variation in the one-day low temperatures than the seven-day average high temperatures.

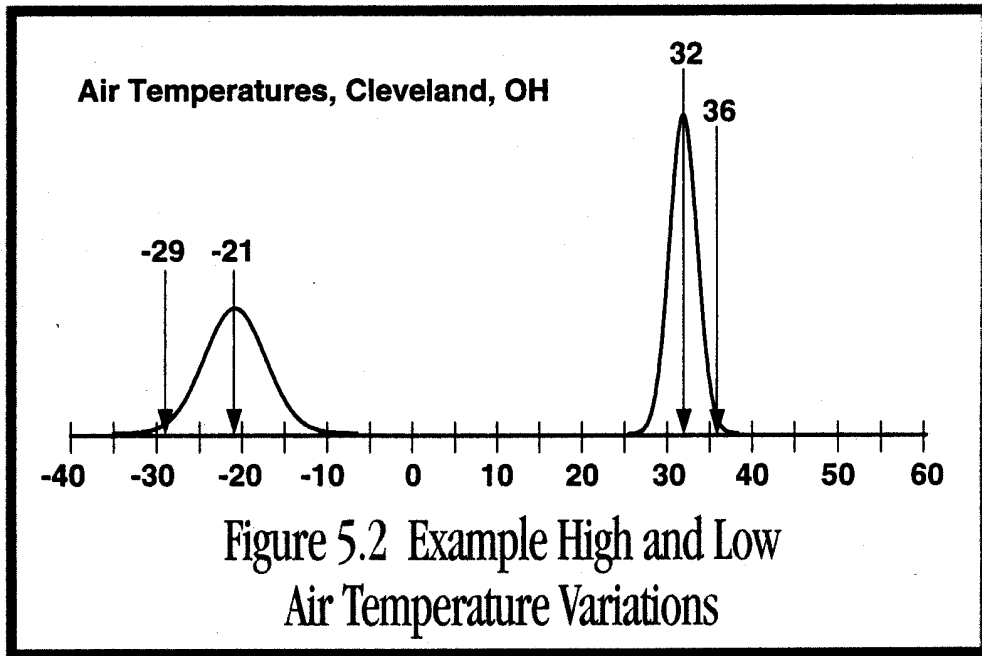

Pavement Temperature Selection

Continuing the example, for a surface course in Cleveland (latitude = 41.42 degrees) the design pavement temperatures are calculated to be about 52°C and -16°C for 50 percent reliability and about 56°C and -23°C for 98 percent reliability (mean plus two standard deviations). Figure 5.3 graphically represents the statistical variation of the two pavement temperatures.

Binder Grade Selection Based

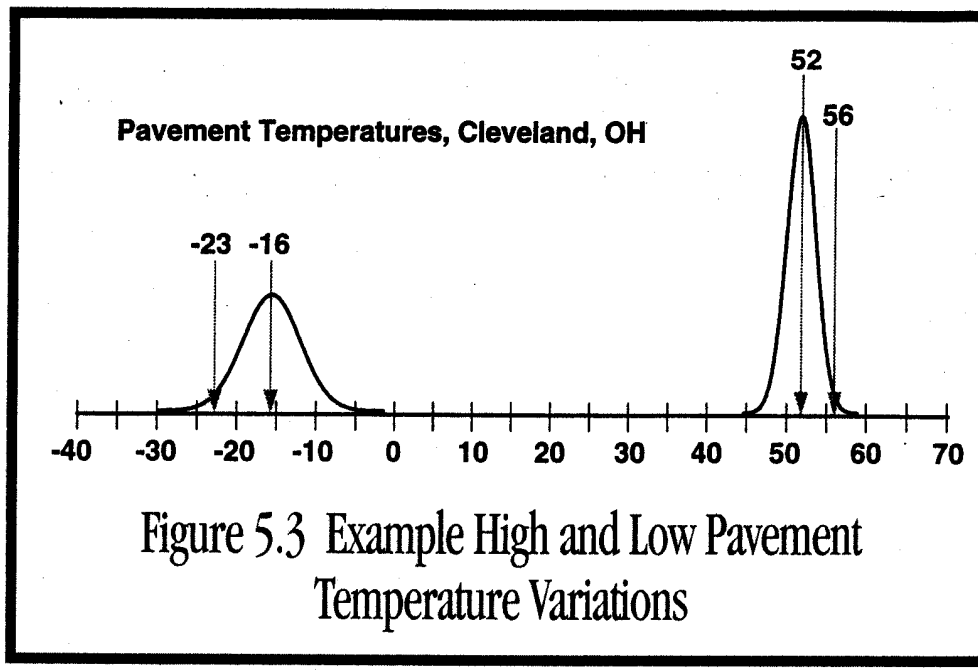

To achieve a reliability of at least 50 percent and provide for an average maximum pavement temperature of at least 52°C, the high temperature grade happens to match the design temperature, PG 52. Using the same reasoning, the low temperature grade is a PG -16 to attain 50 percent reliability. Coincidentally, the low temperature grade again happens to match the design temperature, -16. As shown in Figure 5.4, to obtain at least

98 percent reliability, it is necessary to select a high temperature grade of PG 58 to protect above 56°C and a low temperature grade of PG -28 to protect below - 23°C. In both the high and low temperature cases of the PG 58-28 binder grade, the actual reliability exceeds 99 percent because of the "rounding up" caused by the six degree difference between standard grades.

This "rounding up" introduces conservatism into the binder selection process. Another possible source of conservatism occurs when considering the same steps encountered during asphalt binder test classification. Although a specific binder may pass the criteria when tested at lower or higher temperatures, it will nevertheless be classified by "rounding down" to the next "six-degree" step of the grading system. The net result is that a significant factor of safety is included in the binder selection scheme. For example, it is possible that the PG 52-16 binder, selected previously for a minimum of 50 percent reliability for Cleveland may actually have been graded as a PG 56-20, had such a grade existed. Users of this temperature-based stepped grading system for binder selection should recognize that considerable safeguards are already included in the process. Because of these factors, it may not be necessary or cost-effective to require indiscriminately high values of reliability or abnormally conservative high or low temperature grades.

The Superpave computer program performs these calculations based on minimal user input. For any site, the user can enter a minimum reliability and the software will calculate the required asphalt binder grade. Alternatively, the user can specify a desired asphalt binder grade and Superpave will calculate the reliability obtained for the climate at the site. Consequently, agencies are faced with engineering management decisions. They will have to decide the level of reliability to be used. Depending on the policy established by each individual agency, the selected reliability may be a function of road classification, traffic level, Cost, and other factors.

It should be emphasized that proper or conservative binder selection does not guarantee total pavement performance. Fatigue cracking performance is greatly affected by the pavement structure and traffic. Permanent deformation or rutting is directly a function of the shear strength of the mix, which is greatly influenced by aggregate properties. Pavement low temperature cracking correlates most significantly to the binder properties. Engineers should try to achieve a balance among the many factors when selecting binders.

Selected contents of the complete weather station database contained in Superpave are available in Report SHRP-A-648, "Weather Database for the Superpave™ Mix Design System." The report includes tables of site location and calculated temperatures and binder selection for 50 and 98 percent reliability.

Pavement Temperature Adjusting Binder Grade Selection for Traffic Speed and

The asphalt binder selection procedure described is the basic procedure for typical highway loading conditions. Under these conditions, it is assumed that the pavement is subjected to a design number of fast, transient loads. For the high temperature design situation, controlled by specified properties relating to permanent deformation, the speed of loading has an additional effect on performance. A proposed modification to the AASHTO MP1 specification includes an additional shift in the selected high temperature binder grade to account for slow transient and standing load applications. Similar to the time-temperature shift described with the test temperature for the BBR (testing at 10°C higher temperature reduced the test duration from 2 hours to 60 seconds), higher maximum temperature grades are used to offset the effect of the slower loading speed. For slow moving design loads, the binder should be selected one high temperature grade to the right (one grade "warmer"), such as a PG 64 instead of a PG 58. For standing design loads, the binder should be selected two high temperature grades to the right or two grades "warmer", such as a PG 70 instead of a PG 58.

Also, an additional shift is proposed for extraordinarily high numbers of heavy traffic loads. These are locations where the design lane traffic is expected to exceed 10,000,000 equivalent single axle loads (ESAL). An ESAL is defined as one 18,000-pound (8Q-kN) four-tired dual axle and is the unit used by most pavement thickness design procedures to quantify the various types of axle loadings into a single design traffic number. If the design traffic is expected to be between 10,000,000 and 30,000,000 ESAL, then the engineer may consider selecting one high temperature binder grade higher than the selection based on climate. If the design traffic is expected to exceed 30,000,000 ESAL, then the binder should be selected one high temperature grade higher.

References:

Additional, more detailed information regarding the SHRP research and the Superpave binder and mixture specifications can be found in current and future SHRP publications. These publications include:

"*The Superpave Mix: Design Manual for New Construction and Overlays*," Report SHRP-A-407.

"*The Super Mix Design System - Manual of Specifications, Test Methods, and Practices*," Report SHRP-A-379.

"*Binder Characterization and Evaluation -Volume 3: Physical Characterization*," Report SHRP-A-369.

A2 COLORADO DEPARTMENT OF TRANSPORTATION ASPHALT BINDER SELECTION METHOD (from CDOT's *Pavement Design Manual*)

A.2 Selection of Asphalt Cement for Superpave Mix Design

A.2.1 Asphalt Cement Selection for the Superpave System as Implemented by CDOT. The Superpave System specifies asphalt cement properties to address pavement performance for the climate and traffic found in the specific area of the project. The high and low temperature properties required are then specified according to a percent reliability against rutting (high temperature properties) and cracking (low temperature properties) found for a given pavement. The design temperatures used to select asphalt cement grades are pavement temperatures. The Superpave System defines the high pavement design temperature at a depth of 20 mm below the pavement surface, and the low pavement design temperature at the pavement surface.

The physical properties that the asphalt cement are required to meet stay the same. What changes is the temperature at which the asphalt cement properties must be met. For example, a PG 64-22 means that the asphalt cement must meet the required physical properties up to at least 64 °C and the low temperature properties must be met down to a temperature of -22°C.

Because of the many climate conditions, specifying asphalt cements based on climate conditions results in a very large number of asphalt cements on a nationwide basis, as seen in Table A-5, taken from Table 3-1 of Asphalt Institute Publication, SP-2 (AI SP2) , and repeated here.

Table A-6 Asphalt Cements Available in Colorado

Polymer Modified	Unmodified
PG 76-28	PG 64-22
PG 70-28	PG 58-22
PG 64-28	PG 58-28
PG 58-34	

Only a limited number of the above grades would be needed for Colorado, and additionally, our local suppliers only have the capacity to supply a limited number of asphalt cement grades, because of a limited number of tanks. Table A-6 shows the grades that will be used for CDOT projects in order to obtain acceptable performing Superpave asphalt cements.

The following steps should be followed to determine the proper Superpave asphalt cement grade for a given project:

Step 1: The first decision is to determine what type of project is being designed. For new construction or reconstruction, asphalt cement with 98% reliability for both low and high temperature properties is recommended. For overlays, asphalt cement with a 98% reliability for high temperature properties (rutting resistance) and 50% reliability for low temperature properties (cracking resistance) is recommended. Asphalt cements with lower than 98% reliability against rut resistance should not be specified. In the Superpave system, anything between 50 and 98% reliability is considered 50% reliability for the purpose of binder selection. The low temperatures are specified at a lower reliability for overlays because of reflection cracking .

Step 2: Obtain the Superpave recommended asphalt cement grade, based on weather data and traffic in the project area. These recommendations are found in figures A-1 and A-2, neither of which accounts for grade bumping, and from the computer program LTPPBind, which can be downloaded free from the following internet address: www.tfsrc.gov. LTPPBind is a computer program written by the Long Tenn Pavement Performance (LTPP) Group of the FHWA and contains historical weather information from most of the weather stations in North America. The program also calculates the reliability of various asphalt cements for a given location. Each Region Materials Engineer has a copy of this program. Either of these sources will yield the 98% and 50% reliability asphalt cement for a project area for a free flowing traffic condition, which is described in Step 3. For example, Table A-7 shows how "actual reliability" is used to find "Superpave reliability" and PG grades for Denver- Free Flowing Traffic.

Table A-7 Asphalt Cement Reliability Example

Actual Reliability (high, low)	Superpave Reliability	PG Grade
(98,98)	(98,98)	PG 64-28
(96,98)	(50,98)	PG 58-28
(96,94)	(50,50)	PG 58-22

Step 3: Decide on grade bumping because of traffic speed or loading. Grade bumping means selecting an asphalt cement grade that is one high temperature grade higher than is recommended for the free flowing traffic condition. Traffic types are identified in AASHTO MP2. Free flowing traffic is traffic at speeds greater than 45 mph. Slow moving traffic is traffic moving between 12 and 45 mph. Standing traffic is traffic moving less than 12 mph. Table A-8 shows Superpave recommendations for grade bumping. Total 18k ESAL is determined in Step 1 of section A.1.

Table A-8 Grade Bumping Recommendations

Condition	Recommendation
Slow moving traffic loads	1 grade higher than free flowing
Standing traffic loads	2 grades higher than free flowing
Total 18k ESAL \geq 10,000,000 flowing	1 grade higher than free flowing
Total 18k ESAL \geq 30,000,000 flowing	2 grades higher than free flowing

Tables A-9 and A-10 are guides for high temperature grade bumping to be used for CDOT projects. No adjustment is recommended for the low temperature property requirements, i.e., low temperature grade, because of traffic speed or volume.

Table A-9 Traffic Flow Grade Bumping Recommendation

Traffic Characteristic	High Temperature Grade From Superpave Tables Superpave Tables Assume Free Flowing Conditions			
	Free Flowing	52	58	64
Slow Moving	58	64	70	76
Stop and Go	64	70	76	82

Figure A-2 Colorado 50% Reliability
LTPP High & Low Temperature Models

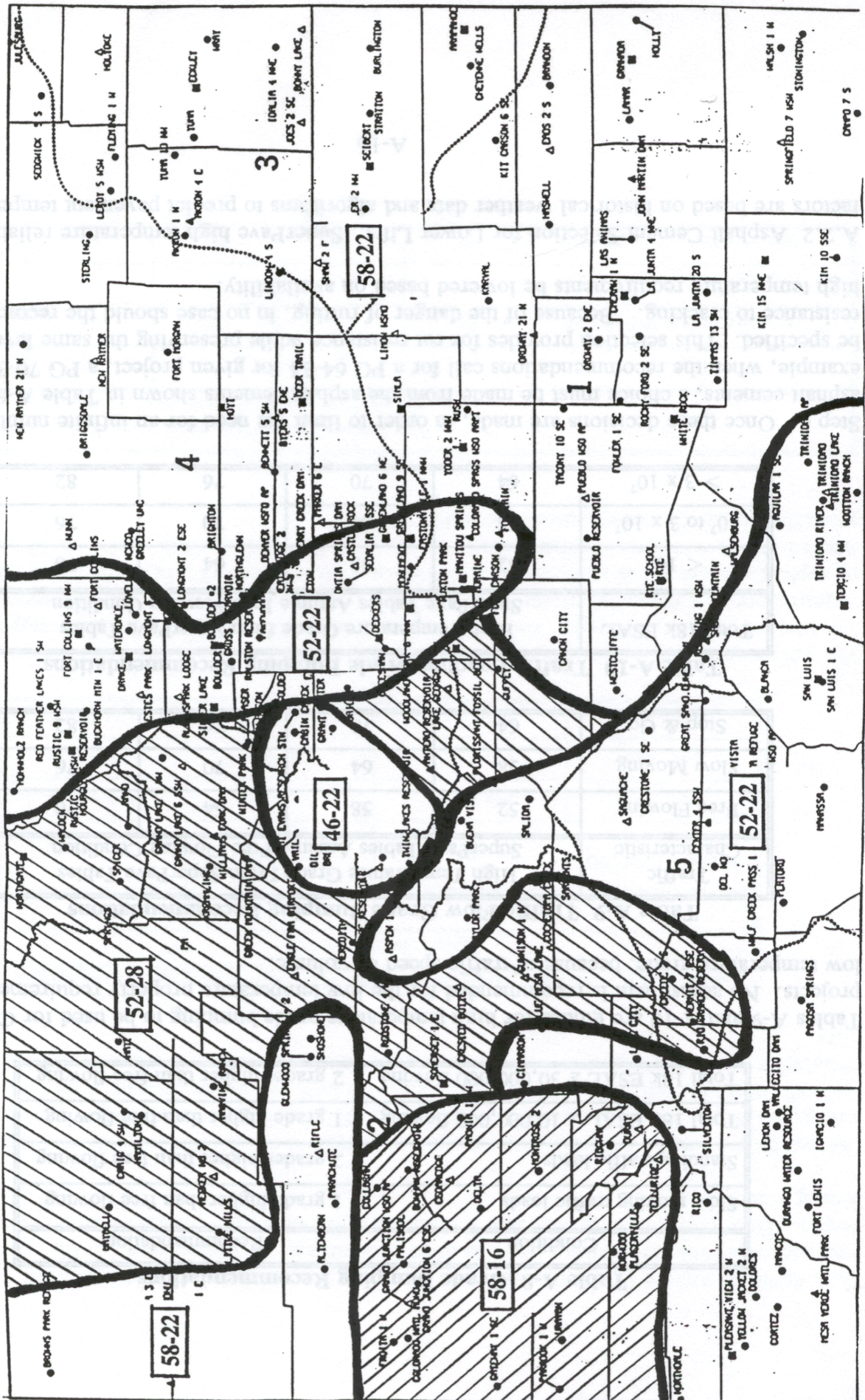

Traffic Characteristic	High Temperature Grade From Superpave Tables Superpave Tables Assume Free Flowing Conditions			
	< 10 ⁷	52	58	64
10 ⁷ to 3x10 ⁷	58	64	70	76
>3x10 ⁷	64	70	76	82

Step 4: Once these decisions are made, in order to limit the need for an infinite number of asphalt cements, a choice must be made from the asphalt cements shown in Table A-6. For example, when the recommendations call for a PG 64-34 for given project, a PG 70-34 would be specified. This selection provides for rut resistance while preserving the same level of resistance to cracking. Because of the danger of rutting, in no case should the recommended high temperature requirements be lowered based on availability.

A.2.2 Asphalt Cement Selection for Lower Lifts. Superpave high temperature reliability factors are based on historical weather data and algorithms to predict pavement temperature.

At a depth to surface layer of 2 inches or more, both the high and low temperature recommendations are changed because of their depth and the temperatures at that pavement depth. This information is available from the weather data program LTPPBIND. See the example in Table A-II.

As can be seen below, the high temperature requirement for the Denver area was lowered by one grade, from 58 to 52, by specifying a depth of 2 inches. The low temperature grade is only slightly lowered, but now the PG-22 has a 98% reliability instead of an 94% reliability against rutting as predicted for the top lift. The starting grade may change for lower lifts.

Table A-11 Example Asphalt Cement Reliability and Grade at Depth

Depth Below Surface			
2 inches (Lower Lift)		0 inch (Top Lift)	
Actual Reliability (high, Low)	PG Grade	Actual Reliability (high, Low)	PG Grade
(98, 98)	PG 52-34	(98, 98)	PG 58-34
(98, 94)	PG 52-28	(98, 84)	PG 58-28
(98, 58)	PG 52-22	(98, 60)	PG 58-22

For pavements with multiple layers, a lesser grade may be specified for lower layers based on the amount of material needed and other economical design decisions. In many cases, the requirements for lower layers might be obtained with an unmodified or more economical grade of asphalt cement. It is recommended that at least 10,000 tons of mix in the lower lift is needed before a separate asphalt cement is specified for the lower lift. Table A-12 shows grade bumping recommendations for lower lifts.

Table A-12 Grade Bumping for Lift

Lift	High Temperature Grade from Superpave Table (Superpave tables assume mix in the top lift)				
	Top	52	58	64	70
2" or more below the top lift	52	52	58	64	70
4" or more below the top lift	52	52	52	58	64
6" or more below the top lift	52	52	52	52	58

APPENDIX B

MGPEC Form #9

MGPEC
Form # 9 (1-14-2005)

**• Mixture Design Requirements for
Hot Mix Asphalt Pavements (HMAP)**

• Project Special Provision Sheet for Hot Mix Asphalt Pavements (HMAP)

This MGPEC Form #9 is a **mandatory part of the bid documents**, and * shall be filled out by the AGENCY for each mix specified. The Contractor shall include a copy of this form with each Mix Design submittal after the contract is awarded.

* **Street Classification:** _____
(examples: Residential, Collector, Arterial, Industrial, Parking Lot or actual name for Project)

* **Construction Application:** Top Lift Intermediate Lift(s) Bottom Lift(s)
 Patching Other _____

* **Aggregate Gradation:** Grading SX Grading S Grading SG
Top Lift only when 2.5" or less thick lift Lower or Bottom Lift for 2.5" to 3.5" thick lifts Bottom Lifts only when 3.0" to 4.0"+, NEED big rollers

* **RAP Quantity, Maximum:** 0% 20%

* **Mix Design Method & Compaction Level:** Choose Lab Compaction Level ($N_{design} =$) from Traffic Level

Superpave Gyrotory, N_{design} (See Table 9.3.2)

$N_{design} = 50$ ♦ new category (new 2001 Traffic Category Level 0: Paths & non-Vehicular)

$N_{design} = 75$ ♦ N=68 (Traffic Level 1, Traffic Loading: 0 to <300,000 ESALs)
♦ N=76 (Traffic Level 2, Traffic Loading: 300,000 to <1 Million ESALs)
♦ N=86 (Traffic Level 3, Traffic Loading: 1 Million to <3 Million ESALs)

$N_{design} = 100$ ♦ N=96 (Traffic Level 4, Traffic Loading: 3 Million to <10 Million ESALs)
♦ N=109 (Traffic Level 5, Traffic Loading: 10 Million to <30 Million ESALs)

* **Asphalt Binder:** PG 58-28 (For Traffic Levels 1, 2 or 3) ⇒ help reduce low temperature cracks
 PG 64-22 (For Traffic Levels 3, 4 or 5) ⇒ for higher axle load traffic
 PG 76-28 (For Traffic Levels 3, 4 or 5) ⇒ for high priority roads, high axle loads, slow moving or stop & go traffic flow conditions)

• **Target Job Mix Optimum Asphalt Content Selection** (see November 19, 2003 Technical Advisory):

Standard => Choose Target %AC at close to 4.0% (3.5 % to 4.5 % Air Voids per MGPEC 2001 version & CDOT 2001~2002). **Also, all mix design VMA requirements of Table 9.2.1.3 are reduced by 0.3%. Bid prices will be \$ per ton of mix.**

CDOT mix production shift to increase %AC => Choose Target %AC at Air Voids of no more than 1.0% below that established in Standard Method above. Reduced VMA spec as above. Do not violate VFA spec. Field Air Voids to be MINIMUM 3.0%. Bid Price to include all Asphalt Cement, assume maximum increase of 0.3% %AC from 'Standard Target %AC', unless Agency has separate contract bid item.

A completed MGPEC Form #9 shall supplement the MGPEC Construction Specifications defining the contract specific requirements of Item 9: Hot Mix Asphalt Pavement (HMAP). Refer to the Specifications for details.

Appendix C

Web Site Address

Organizations and Associations
in the
Asphalt Industry

APPENDIX C

Web Site Addresses Organizations and Associations in the Asphalt Industry

Asphalt Institute	www.asphaltinstitute.org
Asphalt Pavement Alliance	www.asphaltalliance.com
Association of Asphalt Paving Technologists	www.asphalttechnology.org
Civil Engineering Research Foundation	www.cerf.org/hitec
Colorado Department of Transportation	www.dot.state.co.us
Colorado Contractors Association (CCA)	www.co.agc.org
Federal Highway Administration (FHWA)	www.fhwa.dot.gov
FHWA SHRP Clearing House	www.hend.com/shrp
National Asphalt Pavement Association	www.hotmix.org
National Center for Asphalt Technology (NCAT)	www.eng.auburn.edu/center/ncat
National Highway Institute (NHI)	www.nhi.fhwa.dot.gov
North Central Regional Superpave Center	www.ce.ecn.purdue.edu/~spave
Regional Superpave Center At Austin	www.utexas.edu/research/superpave
Rocky Mountain Asphalt User/Producer Group	www.rockymountainasphalt.com
South Eastern Regional Superpave Center	www.eng.auburn.edu/center/ncat
Transportation Research Board	www.nas.edu/trb